

CTI Transfer Panel

OPERATORS INSTRUCTION MANUAL

GENERAL SAFETY INSTRUCTION

- > This system must always be installed and commissioned by competent and qualified personnel.
- > The maintenance operations must be carried out exclusively by authorised and appropriately trained personnel.
- > For more information see the Technical Instruction Manual.

GENERAL INTRODUCTION

NEW CTI enclosure integrates a new 4-pole changeover switch including electronics' control to meet standard IEC 60947-6-1.



SWITCH MODULE INTERFACE

The new enclosure design allows switch module front panel direct access without opening of the enclosure for:

1. Visualization of the current changeover panel position.
2. Functioning mode selection (Cover closed = Automatic / Cover open = Manual).
3. Handle for manual operation.
4. Handle insertion in manual mode only to guarantee the transfer operation in any situation.
5. Padlocking mechanism only in manual mode.

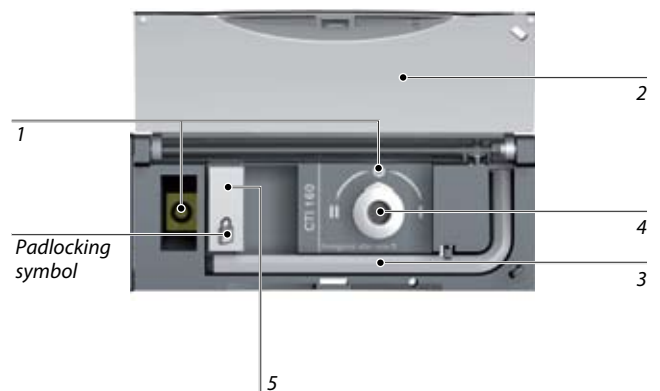

CTI Transfer Panel

OPERATORS INSTRUCTION MANUAL

ELECTRONIC MODULE INTERFACE

The electronic module, also accessible from the front panel, includes:

1. Sources monitoring by Led (Availability, Positions I-0-II).
2. Transfer switches monitoring by Led (Functioning modes, Power supply, Fault).
3. Metering (Voltage (V) and Frequency (F) as standard), Sequences' timers & settings display.
4. Tests operations (On load & Off load).
5. Retransfer Inhibit (RTI) Led and push button.

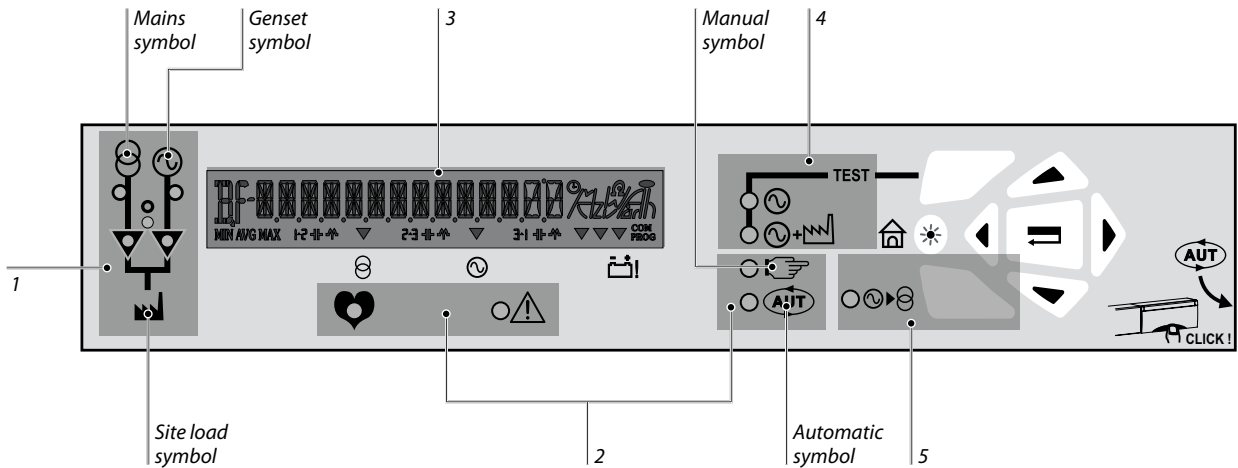

VISUALISATION

> Display

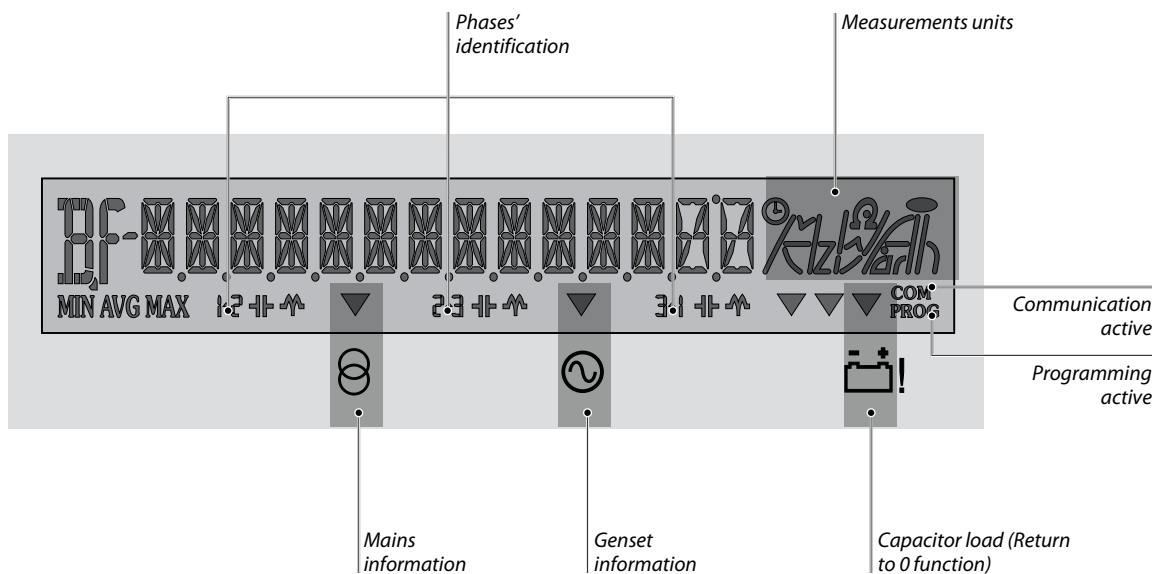





CTI Transfer Panel

OPERATORS INSTRUCTION MANUAL

VISUALISATION

> Led

• Sources availability

Sources	Available	Not available
Mains	 Led on	 Led off
Genset	 Led on	 Led off

• Automatic Transfer Switch positions

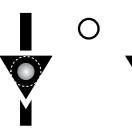
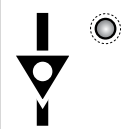
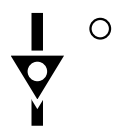
Position I Mains	Position 0	Position II Genset
 Led on	 Led on	 Led on

• Operating modes

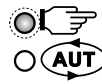
AUTO	MANUAL
 Led on	 Led on

• Lamp test



> Timers

Timer menu		
2Mt	Loss of mains validation timer	(5 sec)
Once mains has disappeared, 2Mt is started. If Mains comes back before 2Mt ends, the commutation cycle is not started. (Delay on Gen start.)		
At	Genset stabilisation timer	(5 sec)
Generator needs to be stable during AT to allow transfer from Mains.		
1Mt	Mains Return validation timer	(120 sec)
Once Mains power has returned 1Mt is started. If Mains power disappears before 1Mt ends, the load is not switched back to the Mains.		

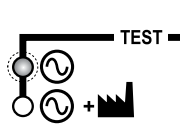

• Test modes

On load	Off load
 Led on	 Led on

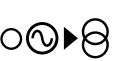

• Retransfer inhibit function

Active	Inactive	Blinking
		Push the RTI button to retransfer

• Power supply

Active	Inactive	Blinking
 Software Error	 Power supply off	Product OK

• Fault synthesis

Active	Inactive
 Product error	 Product OK

Rot	Run on time timer	(240 sec)
Once the load is switched back from the Generator to the Mains, ROT is started and the Generator will stop once ROT is finished. (Allows generator cool down).		
Dbt	Dead Band timer	(5 sec)
This timer is counted down before transferring the load from the Mains source to the Generator or vice versa.		

CTI Transfer Panel

OPERATORS INSTRUCTION MANUAL

OPERATING

> Automatic

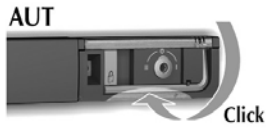

In Auto Mode:

- Possible:
 - the automatic changeovers.
- Not possible:
 - to insert the handle
 - to pull the padlocking mechanism.

> Manual



In Manual Mode:

- Possible:
 - to insert the handle and to operate manually.
- Not possible:
 - to operate electrically.

> Padlocking



In Padlocking Mode:

- Possible:
 - to padlock in position 0 with a standard configuration.
- Not possible:
 - to operate electrically
 - to select the auto mode.

**Please note padlock is not supplied with panel.*

CTI Transfer Panel

OPERATORS INSTRUCTION MANUAL

FAULT FINDING GUIDE

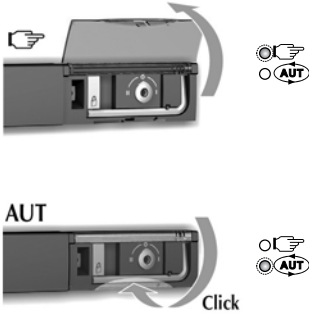
Symptom	Step	Result
01 Automatic operations availability.	01 AUTO Led is on.	<p>> NEGATIVE</p> <ul style="list-style-type: none"> • Check that the switch has not been padlocked. • Check that the manual operating handle has been removed from housing. • Close the Auto/Manu front cover. • Then consult your local dealer.
		<p>> POSITIVE</p> <ul style="list-style-type: none"> • Go to the next step.
	02 Fault synthesis Led is off.	<p>> NEGATIVE</p> <ul style="list-style-type: none"> • Led is on Try to reset the product (see the instructions below). Then consult your local dealer. • Reset 
		<p>> POSITIVE</p> <ul style="list-style-type: none"> • Go to the next step.
	03 Power supply Led is blinking.	<p>> NEGATIVE</p> <ul style="list-style-type: none"> • Consult your local dealer.
		<p>> POSITIVE</p> <ul style="list-style-type: none"> • Go to the next symptoms.
02 The mains availability.	01 Mains availability Led is on.	<p>> NEGATIVE</p> <ul style="list-style-type: none"> • Check lamp test. • Check that the mains return timer (1MT) is still not counting down. • Check that the mains protection system (breaker) is on (Position 1). • Then consult your local dealer.
		<p>> POSITIVE</p> <ul style="list-style-type: none"> • Go to the next steps or symptoms.
03 The genset availability (genset supposed started).	01 Genset availability Led is on.	<p>> NEGATIVE</p> <ul style="list-style-type: none"> • Check lamp test. • Check that the genset stabilisation timer (AT) is still not counting down. • Check that the genset protection system (breaker) is on (Position 1). • Then consult your local dealer.
		<p>> POSITIVE</p> <ul style="list-style-type: none"> • Go to the next steps or symptoms.

CTI Transfer Panel

OPERATORS INSTRUCTION MANUAL

FAULT FINDING GUIDE

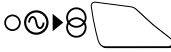
Symptom	Step	Result
04 The product doesn't transfer to the genset in case of mains failure or test on load.	01 AUT Led is on & Fault synthesis Led is off & Power supply Led is blinking.	> NEGATIVE • Go to symptom 01.
		> POSITIVE • Go to the next step.
	02 Genset is started.	> NEGATIVE • Check that the mains failure timer (2MT) is still not counting down. • Check the genset control panel is set to the auto position. • Then consult your local dealer.
		> POSITIVE • Go to the next step.
	03 Genset availability Led is on.	> NEGATIVE • Go to symptom 03.
		> POSITIVE • Consult your local dealer.
05 The product doesn't transfer to the mains in case of mains return or test on load end.	01 AUT Led is on & Fault synthesis Led is off & Power supply Led is blinking.	> NEGATIVE • Go to symptom 01.
		> POSITIVE • Go to the next step.
	02 Mains availability Led is on.	> NEGATIVE • Go to symptom 02.
		> POSITIVE • Go to the next step.
	03 Retransfer inhibit (RTI) function is off.	> NEGATIVE • Push the RTI push button: 
		> POSITIVE • Consult your local dealer.
06 Genset keeps on running after mains restores and switch retransfers to the mains position.	01 AUT Led is on & Fault synthesis Led is off & Power supply Led is blinking.	> NEGATIVE • Go to symptom 01.
		> POSITIVE • Go to the next step.
	02 The run on time timer (ROT) is still counting down (visible on the display).	> NEGATIVE • Check the genset control panel is set to the auto position. • Then consult your local dealer.
		> POSITIVE • Wait for the ROT end.

CTI Transfer Panel

OPERATORS INSTRUCTION MANUAL

FAULT FINDING GUIDE

Symptom	Step	Result
07 Switch manual operations are not possible.	01 The manual operation is possible	> NEGATIVE • Check the required rotation of the switch • Check that the sufficient torque has been applied. • Then consult your local dealer.
		> POSITIVE • Goal reached.
08 Switch padlocking operations are not possible.	01 Possible to pull the padlocking mechanism	> NEGATIVE • Check that the product is in the 0 position for standard configuration. • Then consult your local dealer.
		> POSITIVE • Goal reached.

CTI Transfer Panel

OPERATORS INSTRUCTION MANUAL

CONDITIONS OF USE



Hygrometry:
• 80% humidity without condensation at 55 °C
• 95% humidity without condensation at 40 °C



Temperature:
• -10 +40 °C without de-rating
• +40 +65 °C with de-rating*



Ingress Protection:
• Enclosed: IP40
• Loose: IP2x



Storage:
• Temperature -20 to +40 °C
• Period: 1 year max



Power input:
• $V_n = 230\text{Vac} \rightarrow [176 / 305\text{Vac}]$

* For de-rating information see Instruction Manual.

INSTRUCTION MANUAL REFERENCE

> For detailed instruction & installation guide, please refer to:

