

Installation, Operation, and
Maintenance Manual

95-0057-0000_3.0

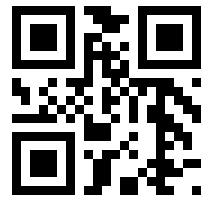

NC series

Godwin Dri-Prime[®] Pumps

godwin 
a xylem brand

Table of Contents

1 Introduction and Safety.....	4
1.1 Introduction.....	4
1.2 Safety.....	4
1.2.1 Safety terminology and symbols.....	4
1.2.2 Protecting the environment.....	5
1.2.3 User safety.....	5
1.3 Product warranty.....	6
2 Transportation and Storage.....	8
2.1 Inspect the unit.....	8
2.2 Transportation guidelines.....	8
2.2.1 Connect the trailer to the towing vehicle.....	8
2.2.2 Disconnection from the towing vehicle.....	9
2.2.3 Fasten the unit.....	9
2.2.4 Lifting.....	11
2.3 Storage guidelines.....	15
2.3.1 Short-term storage.....	15
2.3.2 Long-term storage.....	15
3 Product Description.....	16
3.1 General description.....	16
3.1.1 California proposition 65.....	16
3.2 Operation specifications.....	17
3.3 Nameplates.....	17
4 Installation.....	19
4.1 Pre-Installation.....	19
4.1.1 Pump location guidelines.....	19
4.1.2 Check fluid levels.....	19
4.2 Piping checklists.....	21
4.2.1 General piping checklist.....	21
4.2.2 Suction-piping checklist.....	22
4.2.3 Discharge piping checklist.....	23
4.2.4 Final piping checklist.....	24
4.3 Permanent installation for skid mounted units.....	24
4.3.1 Prepare the skid.....	24
4.3.2 Requirements for foundation and anchor bolts.....	25
4.3.3 Place the skid.....	25
4.3.4 Fabricate the grout forms.....	26
4.3.5 Pour the grout.....	26
4.4 Pump-to-driver alignment.....	27
4.4.1 Alignment checks.....	28
4.4.2 Alignment measurement guidelines.....	28
4.4.3 Attach the dial indicators for alignment.....	29
4.4.4 Pump-to-driver alignment instructions.....	29
5 Commissioning, Startup, Operation, and Shutdown.....	31
5.1 Preparation for startup.....	31
5.1.1 Heavily contaminated liquid.....	31
5.1.2 Operate the unit with the system condition of flooded suction.....	32

5.1.3 Bearing lubrication.....	33
5.1.4 Mechanical seal coolant.....	34
5.2 Pump operation precautions.....	36
5.3 Start the pump.....	36
5.4 Shut down the pump.....	37
6 Maintenance.....	38
6.1 Routine maintenance precautions.....	38
6.2 Replace the compressor belt.....	38
6.2.1 Remove the battery cable.....	38
6.2.2 Remove the compressor belt guard.....	40
6.2.3 Disengage the coupling hub.....	41
6.2.4 Remove the compressor belt.....	42
6.2.5 Install the compressor belt.....	44
6.2.6 Install the coupling hub.....	45
6.2.7 Install the compressor belt guard.....	46
6.3 Daily maintenance.....	47
6.3.1 Engine maintenance.....	47
6.3.2 Pump maintenance.....	48
6.3.3 Acoustic enclosure maintenance.....	48
6.3.4 Air compressor maintenance.....	48
6.3.5 Vacuum pump maintenance.....	48
6.3.6 Gearbox maintenance.....	48
6.3.7 Ejector silencer maintenance.....	48
6.4 After the first 100 hours.....	48
6.4.1 Air compressor maintenance.....	48
6.5 After the first 200 hours.....	49
6.5.1 Gearbox maintenance.....	49
6.6 250 hour maintenance.....	49
6.6.1 Pump maintenance.....	49
6.6.2 Engine maintenance.....	49
6.6.3 Motor maintenance.....	50
6.6.4 Air compressor maintenance.....	50
6.6.5 Vacuum pump maintenance.....	50
6.7 500 hour maintenance.....	51
6.7.1 Air compressor.....	51
6.7.2 Vacuum pump maintenance.....	51
6.8 1000 hour maintenance.....	51
6.8.1 Air compressor.....	51
6.8.2 Vacuum pump maintenance.....	51
6.8.3 Gearbox maintenance.....	51
6.9 2000 hour maintenance.....	52
6.9.1 Air compressor.....	52
6.10 5000 hour maintenance.....	52
6.10.1 Pump maintenance.....	52
6.11 Trailer maintenance.....	52
6.11.1 Before each journey.....	52
6.11.2 After every 500 miles.....	52
6.11.3 After every 6000 miles.....	53
6.11.4 After every 12000 miles.....	53
6.11.5 After every 24000 miles.....	53
7 Troubleshooting.....	54
7.1 Troubleshooting precautions.....	54
7.2 Troubleshooting – Pump.....	54
7.3 Troubleshooting – Driver.....	57
7.4 Troubleshooting – Trailer.....	58

8 Technical Reference	61
8.1 Designations, sizes, and capacities.....	61
8.2 Coolants and lubricants.....	61
8.3 Torque values.....	62
8.4 Belt tensioning.....	63
8.4.1 Force and deflection method.....	63
8.4.2 Belt frequency method.....	64
8.4.3 Belt tension values.....	64
8.5 Impeller to wear plate clearances.....	65

1 Introduction and Safety

1.1 Introduction

Purpose of this manual

The purpose of this manual is to provide necessary information for:

- Installation
- Operation
- Maintenance



CAUTION:

Read this manual carefully before installing and using the product. Improper use of the product can cause personal injury and damage to property, and may void the warranty.

NOTICE:

Save this manual for future reference, and keep it readily available at the location of the unit.

1.2 Safety



WARNING:

- The operator must be aware of safety precautions to prevent physical injury.
- Operating, installing, or maintaining the unit in any way that is not covered in this manual could cause death, serious personal injury, or damage to the equipment. This includes any modification to the equipment or use of parts not provided by Xylem. If there is a question regarding the intended use of the equipment, please contact a Xylem representative before proceeding.
- Do not change the service application without the approval of an authorized Xylem representative.



CAUTION:

You must observe the instructions contained in this manual. Failure to do so could result in physical injury, damage, or delays.

1.2.1 Safety terminology and symbols



About safety messages

It is extremely important that you read, understand, and follow the safety messages and regulations carefully before handling the product. They are published to help prevent these hazards:

- Personal accidents and health problems
- Damage to the product and its surroundings
- Product malfunction



Hazard levels

Hazard level	Indication
 <p>DANGER:</p>	<p>A hazardous situation which, if not avoided, will result in death or serious injury</p>

Hazard level	Indication
 WARNING:	A hazardous situation which, if not avoided, could result in death or serious injury
 CAUTION:	A hazardous situation which, if not avoided, could result in minor or moderate injury
NOTICE:	Notices are used when there is a risk of equipment damage or decreased performance, but not personal injury.

Special symbols

Some hazard categories have specific symbols, as shown in the following table.

Electrical hazard	Magnetic fields hazard
 Electrical Hazard:	 CAUTION:

1.2.2 Protecting the environment

Emissions and waste disposal

Observe the local regulations and codes regarding:

- Reporting of emissions to the appropriate authorities
- Sorting, recycling and disposal of solid or liquid waste
- Clean-up of spills

Exceptional sites



CAUTION: Radiation Hazard

Do NOT send the product to Xylem if it has been exposed to nuclear radiation, unless Xylem has been informed and appropriate actions have been agreed upon.

Recycling guidelines

Always follow local laws and regulations regarding recycling.

1.2.3 User safety

General safety rules

These safety rules apply:

- Always keep the work area clean.
- Pay attention to the risks presented by gas and vapors in the work area.
- Avoid all electrical dangers. Pay attention to the risks of electric shock or arc flash hazards.
- Always bear in mind the risk of drowning, electrical accidents, and burn injuries.

Safety equipment

Use safety equipment according to the company regulations. Use this safety equipment within the work area:

- Hard hat
- Safety goggles, preferably with side shields

- Protective shoes
- Protective gloves
- Gas mask
- Hearing protection
- First-aid kit
- Safety devices

NOTICE:

Never operate a unit unless safety devices are installed. Also see specific information about safety devices in other chapters of this manual.

Electrical connections

Electrical connections must be made by certified electricians in compliance with all international, national, state, and local regulations. For more information about requirements, see sections dealing specifically with electrical connections.

Wash the skin and eyes

Follow these procedures for chemicals or hazardous fluids that have come into contact with your eyes or your skin:

Condition	Action
Chemicals or hazardous fluids in eyes	<ol style="list-style-type: none"> 1. Hold your eyelids apart forcibly with your fingers. 2. Rinse the eyes with eyewash or running water for at least 15 minutes. 3. Seek medical attention.
Chemicals or hazardous fluids on skin	<ol style="list-style-type: none"> 1. Remove contaminated clothing. 2. Wash the skin with soap and water for at least 1 minute. 3. Seek medical attention, if necessary.

Hazardous liquids

The product is designed for use in liquids that can be hazardous to your health. Observe these rules when you work with the product:

- Make sure that all personnel who work with biologically hazardous liquids are vaccinated against diseases to which they may be exposed.
- Observe strict personal cleanliness.

1.3 Product warranty

Coverage

Xylem undertakes to remedy defects in products from Xylem under these conditions:

- The faults are due to defects in design, materials, or workmanship.
- The faults are reported to a local sales and service representative within the warranty period.
- The product is used only under the conditions that are described in this manual.
- The monitoring equipment that is incorporated in the product is correctly connected and in use.
- All service and repair work that is done by Xylem authorized personnel.
- Genuine Xylem parts are used.
- Only Ex-approved spare parts and accessories that are authorized by an Ex-approved Xylem representative are used in Ex-approved products.

Limitations

The warranty does not cover defects that are caused by these situations:

- Deficient maintenance
- Improper installation

- Modifications or changes to the product and installation that are made without consulting a Xylem authorized representative
- Incorrectly executed repair work
- Normal wear and tear

Xylem assumes no liability for these situations:

- Bodily injuries
- Material damages
- Economic losses

Warranty claim

Xylem products are high-quality products with expected reliable operation and long life. However, should the need for a warranty claim arise, contact your local sales and service representative.

2 Transportation and Storage

2.1 Inspect the unit

1. Remove packing materials from the product.
Dispose of all packing materials in accordance with local regulations.
2. Inspect the product to determine if any parts have been damaged or are missing.
3. If applicable, unfasten the product by removing any screws, bolts, or straps.
For your personal safety, be careful when you handle nails and straps.
4. Contact a sales representative if there is any issue.

2.2 Transportation guidelines

Precautions



DANGER: Crush Hazard

Moving parts can entangle or crush. Always disconnect and lock out power before servicing to prevent unexpected startup. Failure to do so could result in death or serious injury.

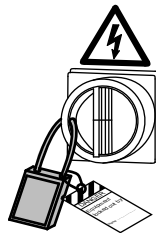

2.2.1 Connect the trailer to the towing vehicle

- Follow all of the highway safety laws that pertain to the tow vehicle and the trailer in your region.
 - Use the proper sized tow vehicle for the load of the trailer.
 - Ensure that the trailer is operational and maintenance steps are complete.
1. Connect the coupling to the tow vehicle, ensure that the coupling has latched correctly.
 2. For trailers, fit the breakaway or safety chain in a loop, fastening back on itself, to a substantial integral point on the tow vehicle.
Ensure that the effective length is as short as possible, but allows for articulation when the vehicle and trailer corner.
 3. For trailers, ensure that the weight is evenly loaded and that the nose weight remains beneath the maximum nose weight.
The maximum nose weight is shown on the coupling itself.
 4. For trailers, connect the trailer lights using the plug and lead provided. Check that all lamps function correctly.
 5. For trailers, verify that the prop stands are raised after the trailer is attached to the tow vehicle.

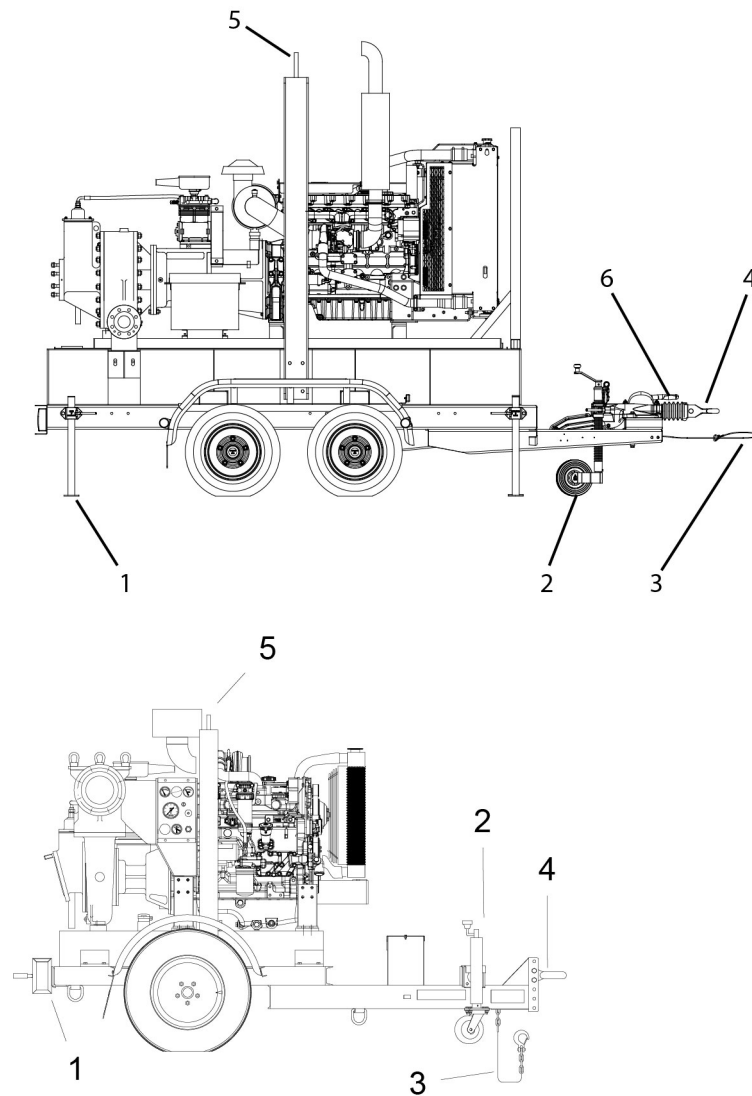

1. Prop stand
2. Jockey wheel
3. Safety chain
4. Coupling
5. Lifting bail (frame)
6. Handbrake

Figure 1: Trailer parts

2.2.2 Disconnection from the towing vehicle



CAUTION:

Tip hazard. Make sure that the prop stands are lowered and locked in place before disconnecting trailer.

2.2.3 Fasten the unit

- Secure the unit with chains. If the chains are not available, then substitute straps with edge protectors.
Do not place straps or chains over the top of the unit.
- Inspect chains and straps for damage. If damaged, then discard and replace.
- Secure the unit using appropriate tie down points on the skid.

- If the skid does not contain D-rings and fork pockets, then place chains and straps around mounting base and tie together at a common point.
- If the skid contains D-rings and fork pockets, then place chains and straps through fork pockets and D-rings.

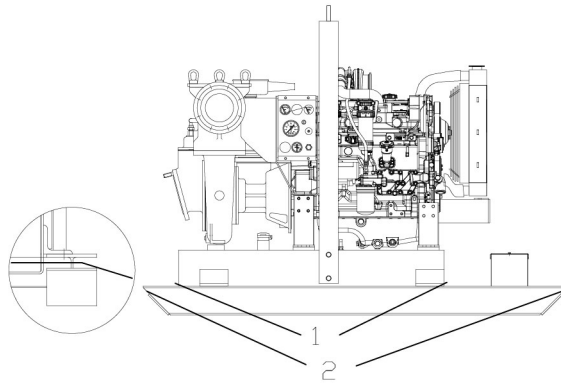

Choose either of the following:

1. Position A.
2. Position B.

Figure 2: Skid without D-rings and fork pockets

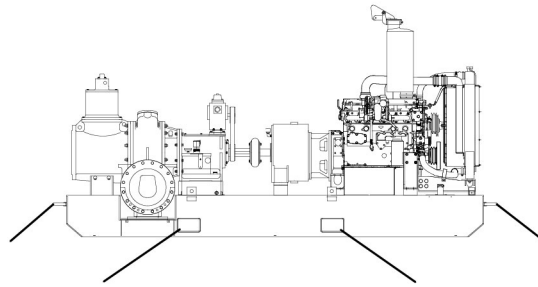

Figure 3: Skid with D-rings and fork pockets

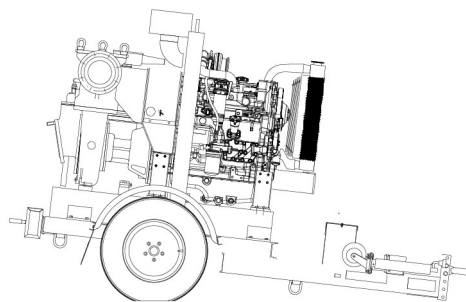

Figure 4: Trailer

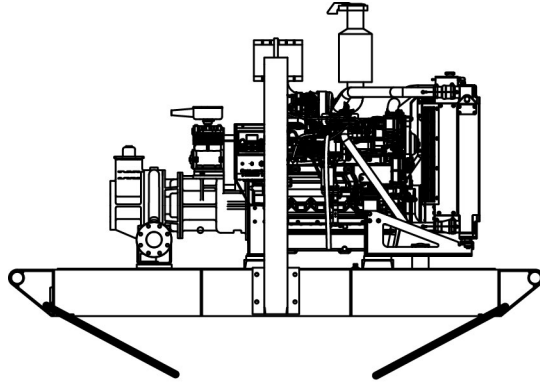

Figure 5: Large skid without D-rings and fork pockets

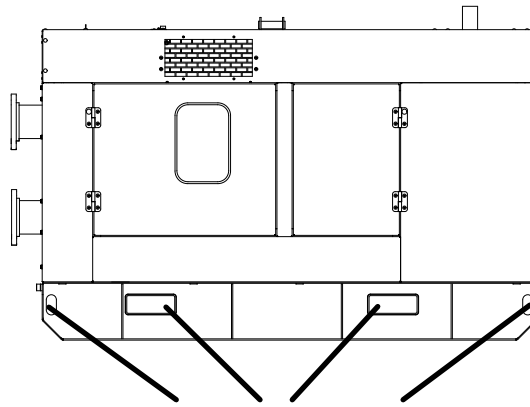

Figure 6: Critically silenced enclosure

2.2.4 Lifting

Always inspect the lifting equipment and tackle before starting any work.



WARNING: Crush Hazard

1) Always lift the unit by its designated lifting points. 2) Use suitable lifting equipment and ensure that the product is properly harnessed. 3) Wear personal protective equipment. 4) Stay clear of cables and suspended loads.

NOTICE:

Never lift the unit by its cables or hose.

2.2.4.1 Requirements for lifting



WARNING:

Lift and handle the product carefully, using suitable lifting equipment.

- The lifting equipment must be in good condition and operated by authorized personnel.
- The lifting equipment must have the lifting capacity for the complete weight of the assembly and its remaining pumped liquid.
- When a crane is used, the minimum height between the lifting hook and the ground must be sufficient to lift the unit straight up and down.

2.2.4.2 Lift unit using a crane

1. Check that the site where the unit is placed has a clean and level surface. Stones and other debris damage the bottom structure of the unit.
2. Fasten a suitable lifting strap or sling to the available lifting points.
3. If the unit was secured to a pallet, flatbed or other surface, then cut the transportation straps.
4. Lift the unit using suitable lifting equipment.
5. Place the unit on firm, level ground.

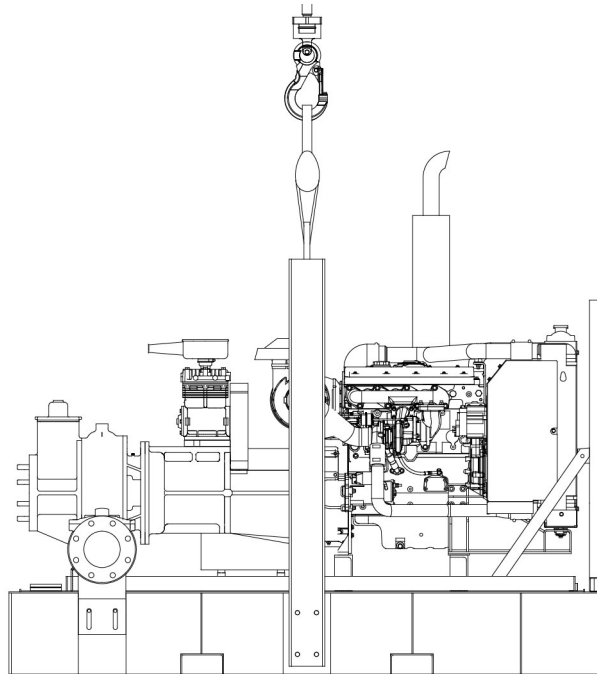

Figure 7: Single lift point skid

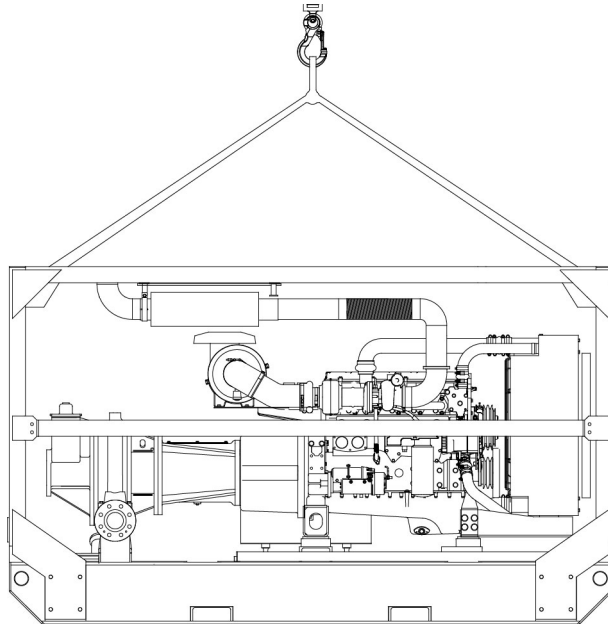

Figure 8: Four lift point skid

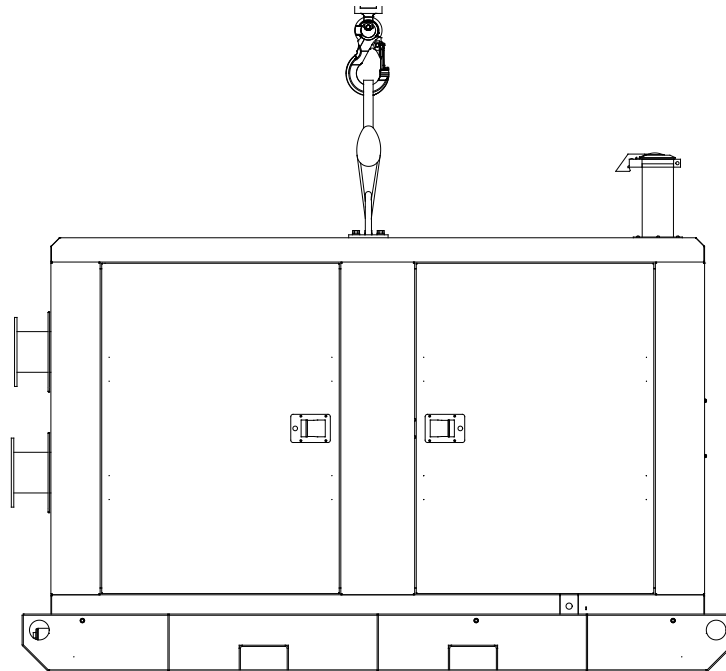

Figure 9: Single lift point enclosure

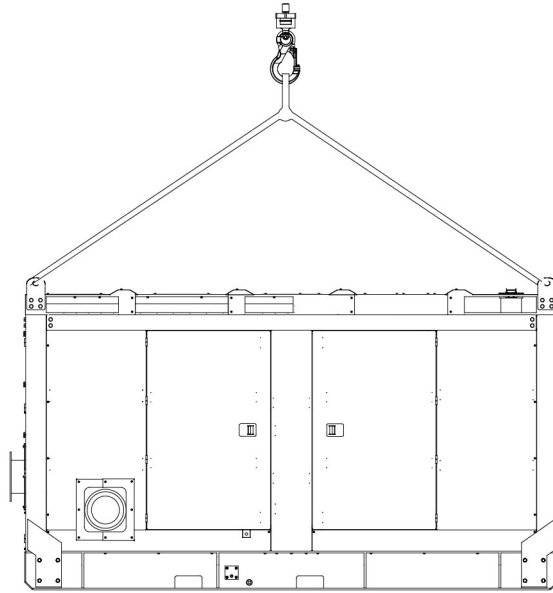

Figure 10: Four lift point enclosure

2.2.4.3 Lift using a forklift

Lift the unit from either side with the forklift.

1. Align the forklift prongs with the fork pockets in the bottom of the base.
2. Insert the forklift prongs into the fork pockets.
3. Lift the unit and move it to its new position.

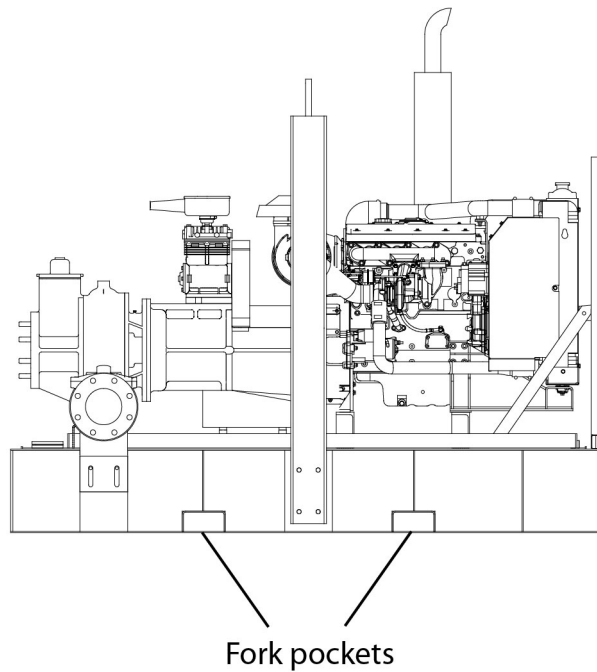

Figure 11: Fork pocket location

2.3 Storage guidelines

Storage location

The product must be stored in a covered and dry location free from heat, dirt, and vibrations.

NOTICE:

Protect the product against humidity, heat sources, and mechanical damage.

NOTICE:

Do not place heavy weights on the packed product.

Freezing precautions

NOTICE:

Do not expose an idle pump to freezing conditions. Drain all liquid that is inside the pump and connected pipes. Failure to do so can cause liquid to freeze and damage the pump.

2.3.1 Short-term storage

Refer to the pump end and the drive unit maintenance manuals for detailed storage instructions.

- Empty the pump of all product and clean surfaces of dirt, debris, oil, fuel, and associated matter.
- Remove the front cover and coat the front of the wear plate and the impeller with an appropriate rust inhibitor.
- Coat any unpainted, machined surfaces that are subjected to rust and corrosion.

If the pump is stored outside and subject to weather, then cover the pump and the engine with a waterproof tarpaulin.

2.3.2 Long-term storage

- Perform all of the steps that are listed in the short-term storage section.
- Store the unit in a covered and dry location.
- Store the unit in a location free from heat, dirt, and vibrations.
- If an engine drives the pump, then perform the following steps:
 - a) Replace the oil and the oil filter.
 - b) Service the air cleaner.
 - c) Drain the fuel tank and add an inhibitor.
 - d) Add an inhibitor to the crank case.
 - e) Disconnect the air intake.
 - f) Disconnect and remove the battery.
 - g) Remove the belts.
 - h) Coat all machined surfaces on the engine with a rust inhibitor.
- Treat bearings and machined surfaces on the unit so that they are well preserved.

3 Product Description

3.1 General description

Materials

The pump is made of a combination of the following materials:

- Iron
- Steel
- Stainless steel
- Aluminium

Pump drive mounting method

The pump has three different methods to mount it to its driver:

- Close-coupled
- Long-coupled (shaft-to-shaft)
- SAE (for engine driven pumps)

Main parts

This table describes the main parts of the pump.

Part	Description
Pump impeller	An open impeller that is mounted to a shaft with one of the following methods: <ul style="list-style-type: none"> • A spline and secured with a screw and an impeller washer • Tapered shaft and adjustable sleeve
Pump casing	The pump casing is <ul style="list-style-type: none"> • known as a volute • equipped with replaceable wear plates
Driver	The pump is driven by one of the following: <ul style="list-style-type: none"> • Diesel engine • Electric motor
Base	The unit is mounted to one of the following: <ul style="list-style-type: none"> • Skidbase • Highway trailer • Acoustic enclosure • Site trolley

Suction and discharge connections

The suction side and discharge side of the pump have different kinds of connections depending on the size of the pump. The smaller connection sizes are threaded onto the pump. The larger connection sizes are flange mounted.

3.1.1 California proposition 65



WARNING:

California Proposition 65 warning! This product contains chemicals known to the state of California to cause cancer and birth defects or other reproductive harm.

3.2 Operation specifications

Liquid characteristics

This table describes the liquid characteristics of the pump.

Parameter	Value
Maximum liquid temperature	80 °C (176 °F) Consult your local Xylem representative for operation that exceeds this temperature.

Maximum pressures

This table specifies the working and suction pressures of each pump model.

Model	Maximum pressure	Maximum suction pressure
NC80	3.3 bar (48 psi)	2.8 bar (41 psi)
NC100	4.9 bar (71 psi)	4.0 bar (58 psi)
NC150	6.2 bar (90 psi)	4.0 bar (58 psi)
NC150S	6.0 bar (87 psi)	4.0 bar (58 psi)
NC350	4.9 bar (71 psi)	4.0 bar (58 psi)

Flanges and connections

This table describes the possible combinations of the flanges and the connections of the pump.

Model	Suction side	Discharge size
NC80	100 mm (4 in) flange	75 mm (3 in) flange
NC100		100 mm (4 in) flange
NC150	150 mm (6 in) flange	150 mm (6 in) flange
NC150S	150 mm (6 in) flange	150 mm (6 in) flange
NC350	400 mm (16 in) flange	400 mm (16 in) flange

3.3 Nameplates

Usage

These numbers located on the nameplate must be quoted in any inquiry for spares or service.

Fields and information

Every unit has a nameplate similar to the one shown in the illustration.

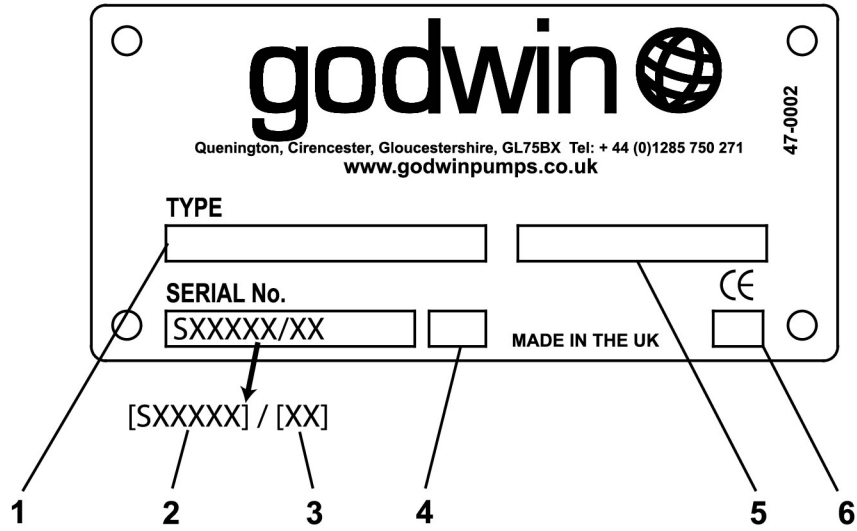

1. Pump model
2. Order number
3. Unit number within order
4. Year of order
5. Extra information such as trimmed impeller size or customer requested information
6. Pressure and vacuum tested

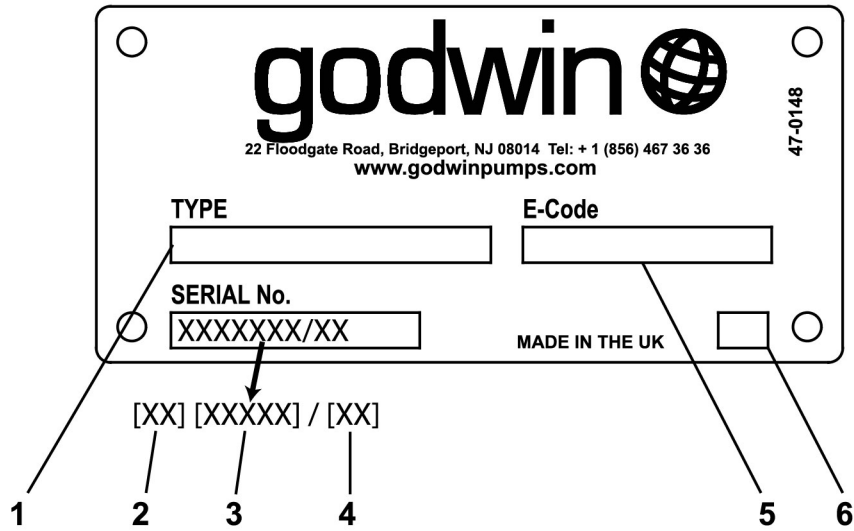

1. Pump model
2. Year of order
3. Order number
4. Unit number within order
5. Xylem reference number
6. Pressure and vacuum tested

Figure 12: Example of a pump nameplate

4 Installation

4.1 Pre-Installation

4.1.1 Pump location guidelines



WARNING:

Fire hazard. Overloaded electrical circuits can cause components to overheat. Make sure to use appropriate circuit protection.



WARNING:

Assembled units and their components are heavy. Failure to properly lift and support this equipment can result in serious physical injury and/or equipment damage. Lift equipment only at the specifically identified lifting points. Lifting devices such as eyebolts, slings, and spreaders must be rated, selected, and used for the entire load being lifted.

Guideline	Explanation/comment
Make sure that the space around the unit is sufficient.	This facilitates ventilation, inspection, maintenance, and service.
If you require lifting equipment such as a hoist or tackle, make sure that there is enough space above the pump.	This makes it easier to properly use the lifting equipment and safely remove and relocate the components to a safe location.
Protect the unit from weather and water damage due to rain, flooding, and freezing temperatures.	This is applicable if nothing else is specified.
Do not install and operate the equipment in closed systems unless the system is constructed with properly-sized safety devices and control devices.	Acceptable devices: <ul style="list-style-type: none"> • Pressure relief valves • Pressure controls • Temperature controls • Flow controls If the system does not include these devices, consult the engineer or architect in charge before you operate the pump.
Take into consideration the occurrence of unwanted noise and vibration.	–
Make sure that the unit location is on solid, level ground.	This ensures that the unit remains stable and balanced while in operation.

4.1.2 Check fluid levels

Ensure that the following fluids are at the correct levels before starting the pump:

- Engine oil
- Engine coolant
- Pump mechanical seal coolant
- Compressor oil, if not connected to a diesel engine
- Engine fuel
- Gearbox oil

Verify general operation

**WARNING:**

Compressed Gas Hazard. Never apply a pressure to any cavity or chamber in the product to test for leakage. Pressurized air may cause parts to be propelled with force. Overpressurization can cause structural failure.

To verify general operation before installing the equipment, pull vacuum with a vacuum pad.

1. Close the drain valve on the volute and the discharge non-return valve.
2. Start the driver and allow it to warm up while idling.
3. Position the vacuum pad on the pump suction flange. Make sure the pad gasket seats firmly around the edge.



4. Raise the driver speed to the normal operating speed. See [Designations, sizes, and capacities](#) on page 61 for operating speeds.
5. Record the reading on the vacuum pad gauge.
6. Verify that the gauge reads 20 - 25 in of mercury (0.70 - 0.75 bar). If not, then begin to troubleshoot the unit.



7. To release the vacuum pad, open the drain valves.

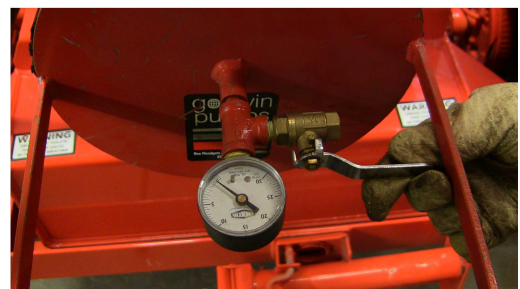

Check the application

- Review the system curve information and ensure that the correct pipe size was chosen.
- Ensure that the suction and discharge requirements for the application have not changed.

For example: The application was originally specified as a suction lift and horizontal open discharge, but now is a flooded suction, horizontal open discharge.

4.2 Piping checklists

4.2.1 General piping checklist

Precautions



CAUTION:

- Never draw piping into place by using force at the flanged connections of the pump. This can impose dangerous strains on the unit and cause misalignment between the pump and driver. Pipe strain adversely affects the operation of the pump, which results in physical injury and damage to the equipment.
- Vary the capacity with the regulating valve in the discharge line. Never throttle the flow from the suction side. This action can result in decreased performance, unexpected heat generation, and equipment damage.
- Use pipes suited to the maximum working pressure of the pump. Failure to do so can cause the system to rupture, with the risk of injury.

Checklist

Check	Explanation/comment	Checked
Check that all piping is supported independently of, and lined up naturally with, the pump connection.	This helps to prevent: <ul style="list-style-type: none"> • Strain on the pump • Misalignment between the pump and the drive unit • Wear on the pump bearings, seal, and shafting See Example section for illustrations of pipe supports.	
Check that only necessary fittings are used.	This helps to minimize friction losses.	
Make sure that all the piping joints and fittings are airtight.	This prevents air from entering the piping system or leaks that occur during operation.	
If the pump handles corrosive fluids, make sure that the piping allows you to flush out the liquid before you remove the pump.	This protects the employees and operators.	
If the pump handles liquids at elevated temperatures, make sure that the expansion loops and joints are properly installed.	This helps to prevent misalignment due to thermal expansion of the piping.	
If the pump handles corrosive liquids, make sure that the piping is correctly rated for the application.	–	

Example: Pipe supports

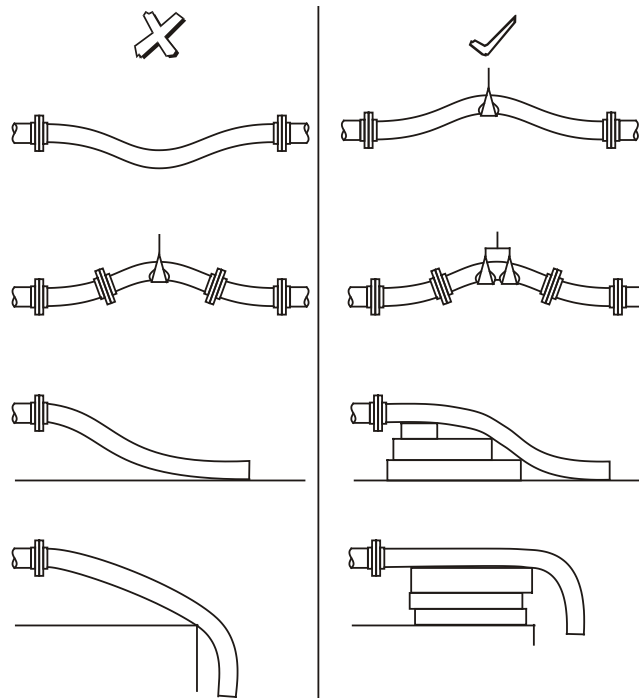

4.2.2 Suction-piping checklist

Performance curve reference



CAUTION:

Vary the capacity with the regulating valve in the discharge line. Never throttle the flow from the suction side. This action can result in decreased performance, unexpected heat generation, and equipment damage.

Net positive suction head available ($NPSH_A$) must always exceed $NPSH_R$ as shown on the published performance curve of the pump.

Suction-piping checks

Check	Explanation/comment	Checked
Check that the distance between the inlet flange of the pump and the closest elbow is at least four pipe diameters.	This minimizes the risk of cavitation in the suction inlet of the pump due to turbulence.	
Check that elbows in general do not have sharp bends.	–	
Check that the eccentric reducer at the suction flange of the pump has the following properties: <ul style="list-style-type: none"> • Sloping side down • Horizontal side at the top 	–	
If suction strainers or suction bells are used, check that they are at least three times the area of the suction piping.	Suction strainers help to prevent clogging.	
If more than one pump operates from the same liquid source, check that separate suction-piping lines are used for each pump.	This recommendation helps you to achieve a higher pump performance.	
If necessary, make sure that the suction piping includes a drain valve and that it is correctly installed.	–	

Liquid source below the pump

Check	Explanation/comment	Checked
Make sure that the suction piping is free from air pockets.	This helps to prevent the occurrence of air and cavitation in the pump inlet.	
Check that the suction piping slopes upwards from the liquid source to the pump inlet.	–	
Check that all joints are air-tight.	–	

Liquid source above the pump

Check	Explanation/comment	Checked
Check that an isolation valve is installed in the suction piping at a distance of at least two times the pipe diameter from the suction inlet.	This permits you to close the line during pump inspection and maintenance. Do not use the isolation valve to throttle the pump. Throttling can cause these problems: <ul style="list-style-type: none"> • Loss of priming • Excessive temperatures • Damage to the pump • Voiding the warranty 	
Make sure that the suction piping is free from air pockets.	This helps to prevent the occurrence of air and cavitation in the pump inlet.	
Check that the piping is level or slopes downward from the liquid source.	–	
Make sure that the size of the entrance from the supply is one or two sizes larger than the suction pipe.	–	
Make sure that the suction piping is adequately submerged below the surface of the liquid source.	This prevents air from entering the pump through a suction vortex.	

4.2.3 Discharge piping checklist

Checklist

Check	Explanation/comment	Checked
Check that an isolation valve is, when possible, installed in the discharge line.	The isolation valve is required for: <ul style="list-style-type: none"> • Regulation of flow • Inspection and maintenance of the pump • Regulation of pressure 	
Check that a check valve is installed in the discharge line, between the isolation valve and the pump discharge outlet.	The location between the isolation valve and the pump allows inspection of the check valve. The check valve facilitates priming. It is also used to prevent damage to the pump and seal due to the back flow through the pump, when the drive unit is shut off.	
If increasers are used, check that they are installed between the pump and the isolation valve.	–	
If quick-closing valves are installed in the system, check that cushioning devices are used.	This protects the pump from surges and water hammer.	
Check that a secondary check valve is fitted.	A secondary check valve is required for: <ul style="list-style-type: none"> • Operation within a closed system • High head applications • Suction lifts greater than 23 ft (7 m) with a low slung discharge line 	

4.2.4 Final piping checklist

Check	Explanation/comment	Checked
If electric motor driven, check that the shaft rotates smoothly.	Ensure that the power is disconnected. Rotate the shaft by hand. Make sure that there is no rubbing that leads to excess heat generation or sparks.	
To make sure that pipe strain has not caused any misalignment, recheck the alignment.	If pipe strain exists, then correct the piping.	

4.3 Permanent installation for skid mounted units

Installation stages

After selecting a location and installing the concrete, the permanent installation will consist of the following:

- Preparation of the skid
- Installation of the anchor bolts
- Placement of the skid
- Fabrication of the grout forms
- Pouring of the grout

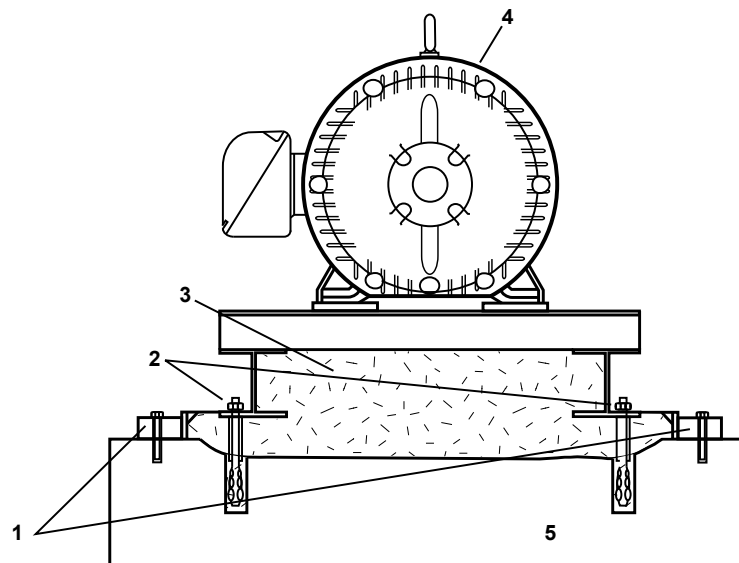

1. Forms
2. Anchor bolts
3. Epoxy grout
4. Motor
5. Concrete

Figure 13: Permanent installation components

4.3.1 Prepare the skid

Required tools and equipment:

- Hoist equipment
- Hand tools
- Sandblaster

1. Disconnect the coupling between the motor and the pump. Remove the motor and the pump from the skid.
2. Turn the skid base upside down. To remove any paint, rust, scale, or debris that may prevent adhesion, sandblast all of the surfaces that will be in contact with the grout.
3. Turn the skid right side up. Coat the jack bolts with anti-sieze lubricant and install. The jack bolts will extend approximately 2-1/2" from the bottom of the skid.

4.3.2 Requirements for foundation and anchor bolts

Foundation

- The foundation must be able to absorb any type of vibration and form a permanent, rigid support for the unit.
- The foundation must be poured on a solid footing using a one-three-five mix that is thick enough to support the pump unit.

Anchor bolts

- The location and size of the anchor bolt holes are shown on the outline assembly drawing for the pump unit.
- Each bolt must be installed with a pipe sleeve around it for adjustment. The inside sleeve diameter must be 2.5 to 3 times the diameter of the bolt.
- The bolt must be held in position during the installation process.
- The area between the bolt and sleeve must be free of concrete.
- The anchor bolt must be long enough to project through the nut 0.25 in or 6.4 mm after allowance has been made for:
 - Grout
 - Height of the jack bolts
 - Skid
 - Anchor bolt nut

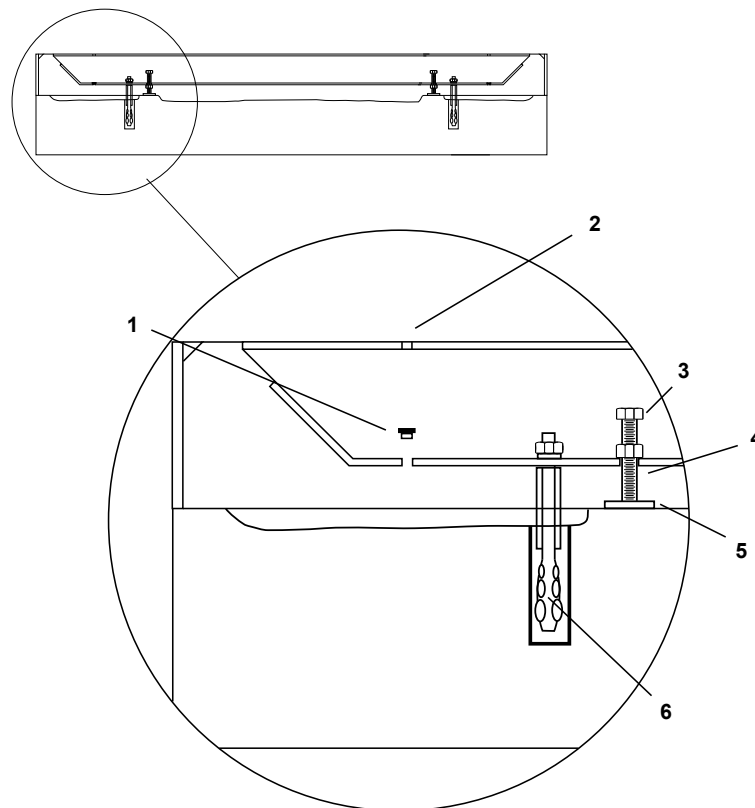

1. Vent hole plug
2. Air release vent
3. Jack bolt
4. Nut welded to the top of the skid
5. Pad
6. Anchor bolt

Figure 14: Installation of the anchor bolts

4.3.3 Place the skid

1. Use jack bolts to level skid base across the motor mounting location and pump base mounting location.

Mounting surfaces elevations should be within 1/16" as measured across the diagonals.

2. Replace the motor on the base plate of the skid so that the motor mounting holes are centered on the base plate motor mount holes.
3. Adjust the jack bolts on the skid base till the suction flange is plumb with the horizon. Place the pump on the skid base with 0.075" of shims under all six mounting holes.
4. Align the motor and pump shafts in the vertical plane to a tolerance of 3 mills offset and 5 mills gap over a 10" coupling by shimming under the motor.
5. The motor holes are rechecked for being concentric with the base plate holes.
This gives maximum potential for final alignment. The pump and motor shafts are then aligned horizontally to a tolerance of 3 mills offset and 5 mills gap over the coupling by moving the pump to the motor.
6. Place a machinist's level on the suction flange of the pump.
7. Tighten the anchor bolt nuts so that the base is tight to the concrete slab.

4.3.4 Fabricate the grout forms

Required materials:

- Hand tools
- 2" x 4" studs
- 1/2" CDX Plywood

1. Install lumber form work around the perimeter of the skid. Form work faces in contact with grout shall be coated with a form release oil or other similar .
2. Form work should be secured to the concrete slab with bolts and drop in anchors to prevent movement while the grout is being placed.
3. All forms should butt tightly against the perimeter of the steel skid base to prevent grout from escaping during the placement.

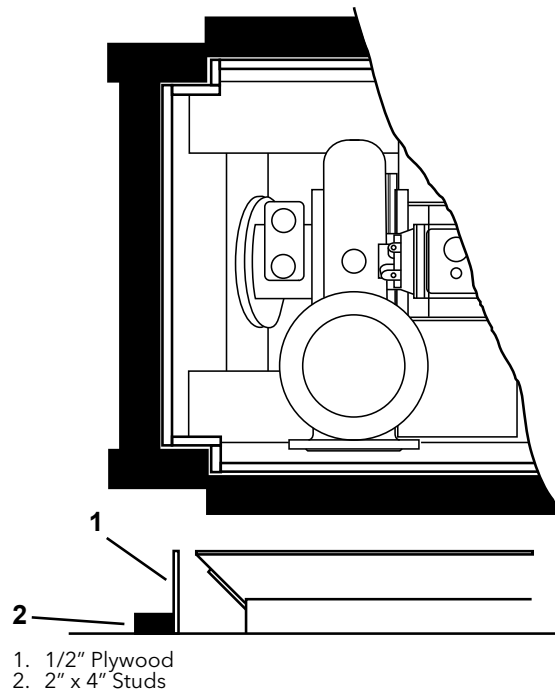
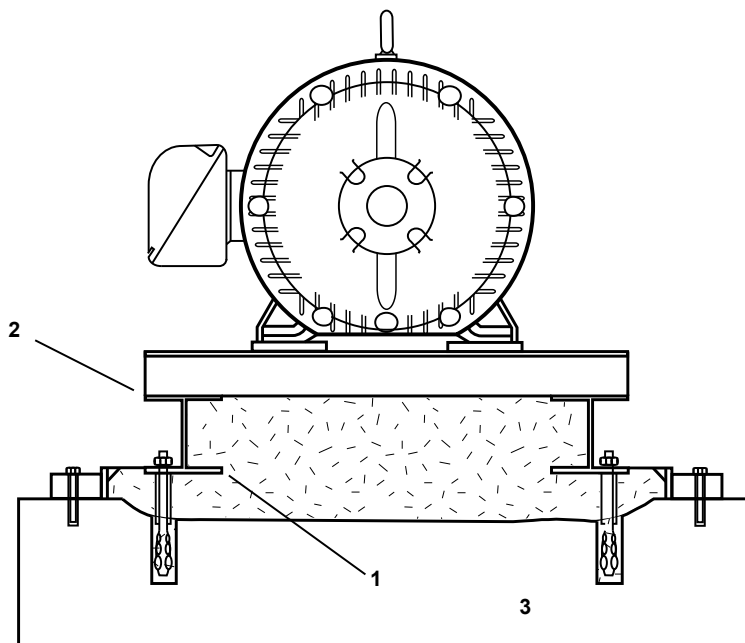

Figure 15: Grout form details

4.3.5 Pour the grout

Required materials:

- Epoxy grout
 - Hand tools
1. Mix epoxy grout components as per the manufacturer's instructions.
 2. Pour grout:
 - a) Pour until the bottom flange is covered.
 - b) Trowel off excess where needed and allow epoxy grout to stand until firm.
 - c) Pour until the top flange is covered.
 - d) Trowel off excess where needed and allow epoxy grout to stand until firm.



1. Bottom flange
2. Top flange
3. Concrete

Figure 16: Grout locations

- The temporary form work may be removed after the epoxy grout has adequately cured, approximately 24 hrs. or per the manufacturer's instructions.
- The base plate should remain supported by the jack bolts for at least 48 hours. The jack bolts can then be removed and the anchor bolts tightened to full strength.

4.4 Pump-to-driver alignment

Precautions



WARNING:

- Follow shaft alignment procedures in order to prevent catastrophic failure of drive components or unintended contact of rotating parts. Follow the coupling installation and operation procedures from the coupling manufacturer.
- Always disconnect and lock out power to the driver before you perform any installation or maintenance tasks. Failure to disconnect and lock out driver power will result in serious physical injury.

NOTICE:

Proper alignment is the responsibility of the installer and the user of the unit. Check the pump-to-driver alignment before you operate the unit. Failure to do so can result in equipment damage or decreased performance.

4.4.1 Alignment checks

When to perform alignment checks

You must perform alignment checks under these circumstances:

- The process temperature changes.
- The piping changes.
- The pump has been serviced.
- Severe vibration while the unit is in operation occurs.
- The pump has been removed.
- The driver has been moved.

Pumps that are close-coupled to a diesel engine do not require alignment.

Types of misalignment

Type of misalignment	Description
Angular misalignment	Shafts have an axis concentric at the intersection but not parallel.
Parallel offset misalignment	Shafts have an axis parallel but offset.

Check and correct angular misalignment before correcting parallel misalignment.

Types of alignment checks

Type of check	When it is used
Initial alignment (cold alignment) check	Prior to operation when the pump and the driver are at ambient temperature.
Final alignment (hot alignment) check	After operation when the pump and the driver are at operating temperature.

Initial alignment (cold alignment) checks

When	Why
Before you grout the baseplate	This ensures that alignment can be accomplished.
After you grout the baseplate and tighten the anchor bolts	This ensures that no changes have occurred during the grouting process.
After you connect the piping	This ensures that pipe strains have not altered the alignment. If changes have occurred, you must alter the piping to remove pipe strains on the pump connections.

Final alignment (hot alignment) checks

When	Why
After the first run	This ensures correct alignment when both the pump and the driver are at operating temperature.
Periodically	This follows the plant operating procedures.

4.4.2 Alignment measurement guidelines

Guideline	Explanation
Rotate the pump coupling half and the driver coupling half together so that the indicator rods have contact with the same points on the driver coupling half.	This prevents incorrect measurement.
Move or shim only the driver in order to make adjustments.	This prevents strain on the piping installations.
Make sure that the hold-down bolts for the driver feet are tight when you take indicator measurements.	This keeps the driver stationary since movement causes incorrect measurement.

Guideline	Explanation
Make sure that the hold-down bolts for the driver feet are loose before you make alignment corrections.	This makes it possible to move the driver when you make alignment corrections.
Check the alignment again after any mechanical adjustments.	This corrects any misalignments that an adjustment may have caused.

4.4.3 Attach the dial indicators for alignment

You must have two dial indicators in order to complete this procedure.

1. Attach two dial indicators on the pump coupling half (X):
 - a) Attach one indicator (P) so that the indicator rod comes into contact with the perimeter of the driver coupling half (Y).
This indicator is used to measure parallel misalignment.
 - b) Attach the other indicator (A) so that the indicator rod comes into contact with the inner end of the driver coupling half.
This indicator is used to measure angular misalignment.

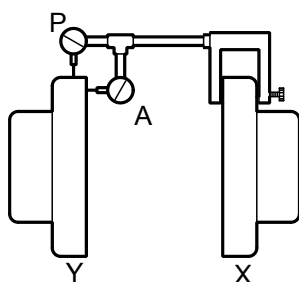

2. Rotate the pump coupling half (X) in order to check that the indicators are in contact with the driver coupling half (Y) but do not bottom out.
3. Adjust the indicators if necessary.

4.4.4 Pump-to-driver alignment instructions

4.4.4.1 Perform parallel alignment for a horizontal correction

Before you start this procedure, make sure that the dial indicators are properly attached for measurement.

A unit is in parallel alignment when the parallel indicator (P) does not vary by more than the values given on the included coupling drawing as measured at four points 90° apart at the operating temperature.

1. Set the parallel alignment indicator (P) to zero on the left side of the driver coupling half (Y), 90° from the top-center position (9 o'clock).
2. Rotate the indicator through the top-center position to the right side, 180° from the start position (3 o'clock).
3. Record the indicator reading.

Reading value	Driver coupling half (Y) placement
Negative	To the left of the pump coupling half (X).
Positive	To the right of the pump coupling half (X).

4. Slide the driver carefully in the appropriate direction.

NOTICE:

Make sure to slide the driver evenly. Failure to do so can negatively affect horizontal angular correction.

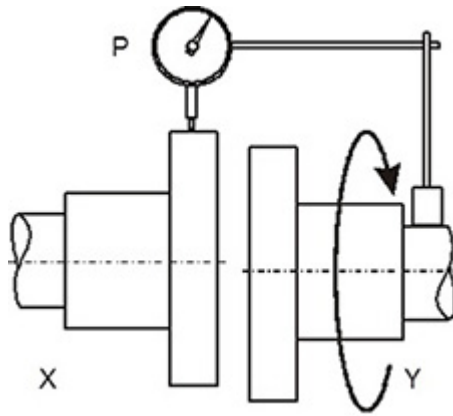

Figure 17: Example of incorrect parallel alignment

5. Repeat the previous steps until the permitted reading value is achieved.

NOTICE:

Use the specified permitted reading values unless specified otherwise by the coupling manufacturer. Failure to do so may result in reducing the reliability of the pump.

4.4.4.2 Perform parallel alignment for a vertical correction

Before you start this procedure, make sure that the dial indicators are properly attached for measurement.

A unit is in parallel alignment when the parallel indicator (P) does not vary by more than the values given on the included coupling drawing as measured at four points 90° apart at the operating temperature.

1. Set the parallel alignment indicator (P) to zero at the top-center position (12 o'clock) of the driver coupling half (Y).
2. Rotate the indicator to the bottom-center position (6 o'clock).
3. Record the indicator reading.

Example illustration given in previous section.

Condition	Action
Negative reading value: The pump coupling half (X) is lower than the driver coupling half (Y).	Remove shims of a thickness equal to half of the indicator reading value under each driver foot.
Positive reading value: The pump coupling half (X) is higher than the driver coupling half (Y).	Add shims of a thickness equal to half of the indicator reading value to each driver foot.

NOTICE:

You must use an equal amount of shims with each driver foot to prevent misalignment. Failure to do so can result in equipment damage or decreased performance.

4. Repeat the previous steps until the permitted reading value is achieved.

NOTICE:

Use the specified permitted reading values unless specified otherwise by the coupling manufacturer. Failure to do so may result in reducing the reliability of the pump.

5 Commissioning, Startup, Operation, and Shutdown

5.1 Preparation for startup



DANGER:

Never put your hand into the pump housing.



WARNING:

Fire hazard. Overloaded electrical circuits can cause components to overheat. Make sure to use appropriate circuit protection.



WARNING:

- Failure to follow these precautions before you start the unit will lead to serious personal injury and equipment failure.
 - Explosion hazard. Do not short battery terminals together or damage the battery.
 - Always disconnect and lock out power to the driver before you perform any installation or maintenance tasks. Failure to disconnect and lock out driver power will result in serious physical injury.
 - Operating the pump in reverse rotation can result in the contact of metal parts, heat generation, and breach of containment.
 - Do not operate the unit if the fuel tank has been damaged.
 - Do not operate the unit in an area where explosive gases are present.
 - Always operate the unit in a well ventilated area, preferably outdoors.
 - Do not refuel the engine while it is running.
 - Always wipe up spilled fuel and oil before operating the unit.
 - Drain oil and moisture residue daily or after each use from the air receiver located on the compressor.
 - Always inspect the conductors on electric motors before operation.
 - The unit and all components must be properly maintained.
 - Do not smoke while refilling the engine.
 - Do not refill an engine near open flames or sparks.
-

NOTICE:

- Verify the driver settings before you start any pump.
-

You must follow these precautions before you start the pump:

- Familiarize yourself with the controls of the driver.
- Flush and clear the system thoroughly to remove dirt or debris in the pipe system in order to prevent premature failure at initial startup.
- Check all fluid levels.

5.1.1 Heavily contaminated liquid

If the unit is contained within an acoustic enclosure and is required to pump heavily contaminated liquid, then do the following:

1. Disconnect the ejector hose from the collection tank.
2. Extend the hose towards the liquid source.
3. To ensure that it reaches the liquid source, add an extension to the hose.

5.1.2 Operate the unit with the system condition of flooded suction

Operation of a pump with the liquid source located above the pump is known as Flooded Suction. To operate this pump with the system condition of flooded suction, you must follow these steps.



WARNING:

Always disconnect and lock out power to the driver before you perform any installation or maintenance tasks. Failure to disconnect and lock out driver power will result in serious physical injury.

1. Isolate the driver and ensure that the unit cannot be started.
2. Disconnect the air line from the priming tower.
3. Select the following step, depending on a compressor unit or vacuum pump unit.
 - Compressor units: disconnect the compressor belt drive.
 - Vacuum pump units: disconnect the vacuum belt drive.
4. Select the following step, depending on a compressor unit or vacuum pump unit.
 - Compressor units: remove the complete ejector housing and replace with a plain blanking plate.
 - Vacuum pump units: remove the complete priming tower and replace with a plain blanking plate.

Blanking plates are available from your local Xylem representative.

5. Ensure that the blanking plate has a leak free seal to the pump.
6. Remove the means of isolation from the driver.
7. To start the pump with the system condition of flooded suction:
 - a) Close the inlet valve.
 - b) Start the driver.
 - c) Open the inlet valve.
 - d) Increase the driver speed.
8. To stop the pump with the system condition of flooded suction:
 - a) Decrease the driver speed.
 - b) Stop the driver.
 - c) Close the inlet valve.

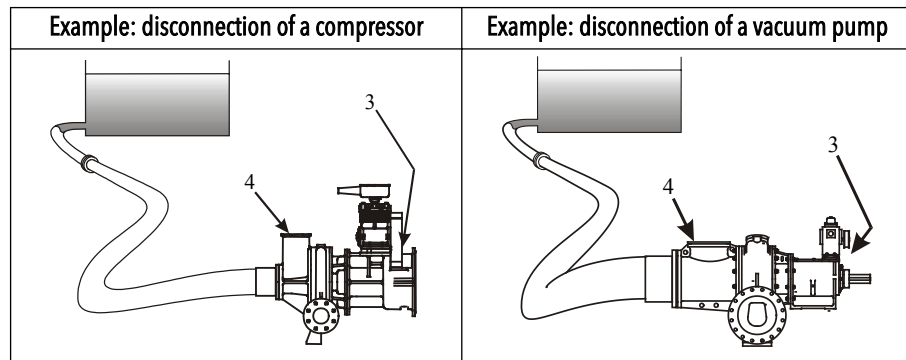

5.1.3 Bearing lubrication

**WARNING:**

Make sure to properly lubricate the bearings. Failure to do so can result in excess heat generation, sparks, and premature failure.

NOTICE:

Be certain to check the greasing on a pump that has been out of service for a long period of time and re-grease if necessary.

- For recommended lubricants, refer to [Technical Reference](#) on page 61.

Locations of lubrication points (X)

Figure 18: Locations on medium bearing bracket



5.1.4 Mechanical seal coolant

All pumps are fitted with mechanical seals that require a coolant.

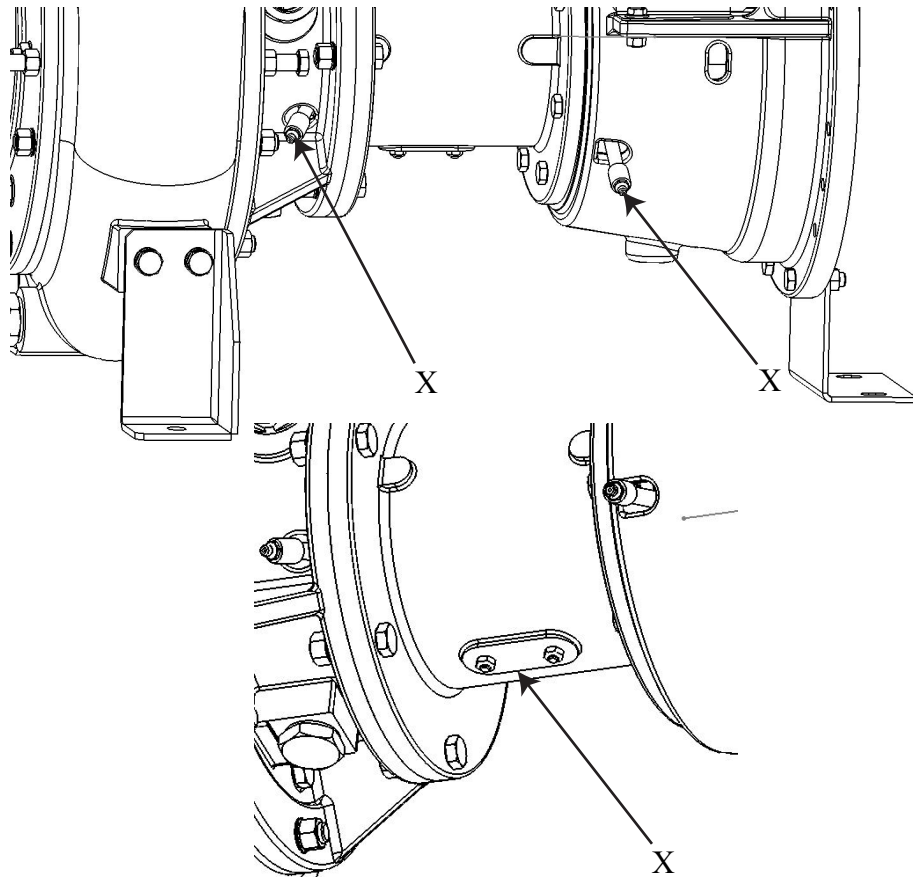
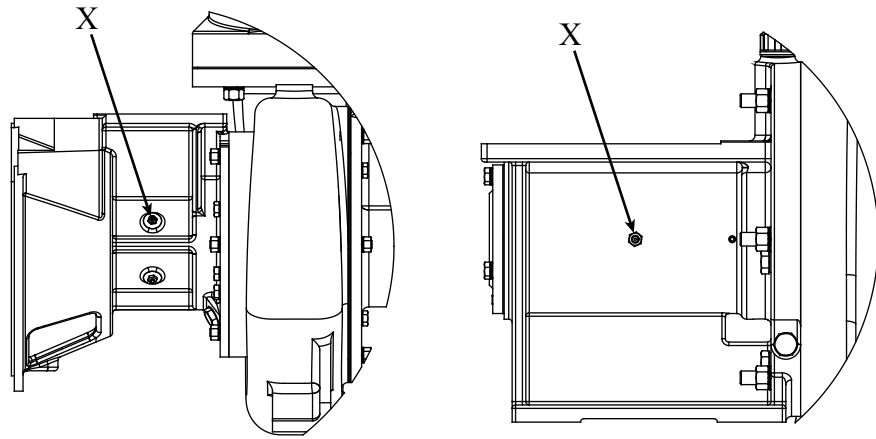
NOTICE:

- Some pumps are not supplied with a seal coolant.
 - Seal oil must be changed at the first sign of contamination.
 - Seal failure caused by the lack of correct and sufficient coolant will void the warranty.
-
- The level of coolant varies due to the operating conditions of the pump. A slight loss of coolant under high suction lift conditions or slight emulsification of oil under low conditions is normal.
 - Check the level of coolant in the seal housing daily.

For required coolants and quantities, refer to [Technical Reference](#) on page 61.

Fill (1) and drain plug (2) locations

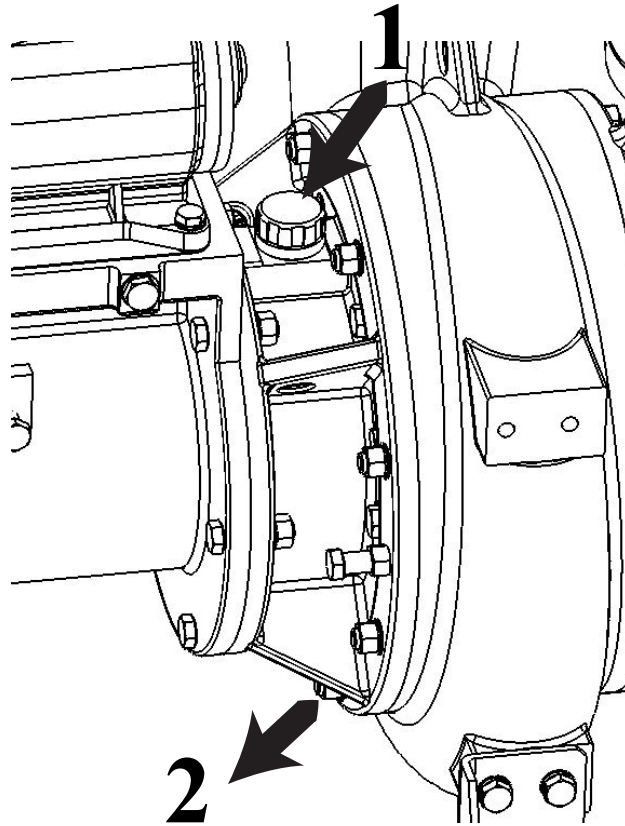

Figure 19: Locations on medium pumps

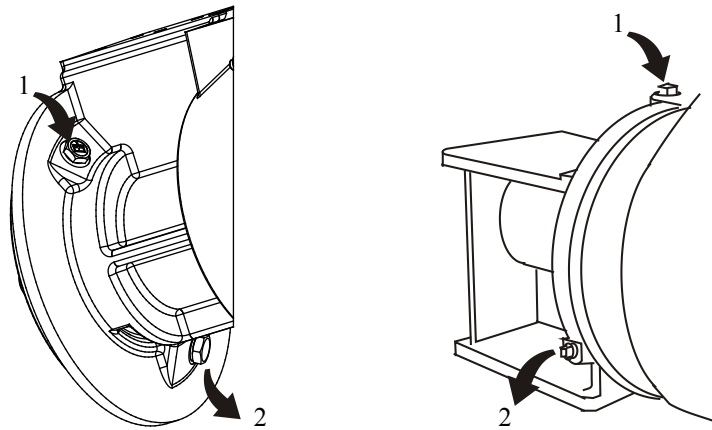

Figure 20: Locations on motor adaptor units and bearing bracket units

5.2 Pump operation precautions

General considerations



CAUTION:

- Vary the capacity with the regulating valve in the discharge line. Never throttle the flow from the suction side since this can result in decreased performance, unexpected heat generation, and equipment damage.
- Do not overload the driver. Driver overload can result in unexpected heat generation and equipment damage. The driver can overload in these circumstances:
 - The specific gravity of the pumped fluid is greater than expected.
 - The pumped fluid exceeds the rated flow rate.
- Make sure to operate the pump at or near the rated conditions. Failure to do so can result in pump damage from cavitation or recirculation.
- Never operate a pump without a properly installed coupling guard. Personal injury will occur if you run the pump without a coupling guard.
- Burn hazard. During operation various surfaces on the unit will become hot. To avoid burn injury, use heat protective gloves.

Operation at reduced capacity



WARNING:

Never operate any pumping system with a blocked suction and discharge. Operation, even for a brief period under these conditions, can cause confined pumped fluid to overheat, which results in a violent explosion. You must take all necessary measures to avoid this condition.

NOTICE:

- Avoid increased radial load. Failure to do so can cause stress on the shaft and bearings.
- Avoid heat build-up. Failure to do so can cause rotating parts to score or seize.
- Avoid cavitation. Failure to do so can cause damage to the internal surfaces of the pump.

Operation under freezing conditions

NOTICE:

Do not expose an idle pump to freezing conditions. Drain all liquid that is inside the pump and connected pipes. Failure to do so can cause liquid to freeze and damage the pump.

5.3 Start the pump



CAUTION:

- Observe the pump for vibration levels, bearing temperature, and excessive noise. If normal levels are exceeded, shut down the pump and resolve the issue.
 - Monitor all gauges to ensure that the pump is running at or near rating and that the suction screen (when used) is not clogged.
-
- These instructions describe operation of the unit with the system condition of suction lift. If the unit is being operated with the system condition of flooded suction, refer to [Operate the unit with the system condition of flooded suction](#) on page 32.
 - If the unit is driven by a diesel engine, check oil level and coolant level. Refer to the engine manual.
 - If the unit is driven by an electric motor, refer to the relevant control requirements.
 - If the unit includes Field Smart Technology (FST), then refer to the FST documentation.

1. If fitted, open the suction valve.
2. If fitted and depending on the system condition, fully close or partially open the discharge valve.
3. Start the driver. The air compressor or vacuum pump will start to prime the pump.
4. If fitted, open the discharge valve until the pump reaches the desired flow.
5. Check the pressure gauge to ensure the pump is operating at the correct discharge pressure.
6. If the pump fails to reach pressure:
 - a) Stop the driver.
 - b) Begin to troubleshoot the unit.

5.4 Shut down the pump

1. Slowly run the driver down to stop.
2. Shut down and lock the driver to prevent accidental rotation.

6 Maintenance

6.1 Routine maintenance precautions

**DANGER:**

Electrical hazard sufficient to kill. Always disconnect and lock out the power before you service the unit.

**WARNING:**

Fire hazard. Overloaded electrical circuits can cause components to overheat. Make sure to use appropriate circuit protection.

**WARNING:**

- Pressurized device. Make sure that the internal pressure is relieved before you continue.
- Compressed Gas Hazard. Never apply a pressure to any cavity or chamber in the product to test for leakage. Pressurized air may cause parts to be propelled with force. Overpressurization can cause structural failure.
- Make sure that the pump is isolated from the system and that pressure is relieved before you disassemble the pump, remove plugs, open vent or drain valves, or disconnect the piping.
- Maintenance and service must be performed by skilled and qualified personnel only.
- Always disconnect and lock out power to the driver before you perform any installation or maintenance tasks. Failure to disconnect and lock out driver power will result in serious physical injury.
- Do not smoke while refilling the engine.
- Do not refill an engine near open flames or sparks.

**CAUTION:**

- Allow all system and pump components to cool before you handle them to prevent physical injury.
- A worn pump can have components that have very sharp edges. Wear protective gloves.
- Wear protective clothing. The edges of the parts can be sharp.
- Read all operation and maintenance manuals supplied with the pump assembly.
- Some engine manufacturers require a break-in period before the 250 hour service. Refer to the engine operation and maintenance manual for the details of the break-in period.

6.2 Replace the compressor belt

The following procedure only applies to the NC150S model pump.

6.2.1 Remove the battery cable

These steps apply to pump assemblies driven by a diesel engine.

1. Verify the control panel switch is in the off position.
2. Remove the battery box lid.

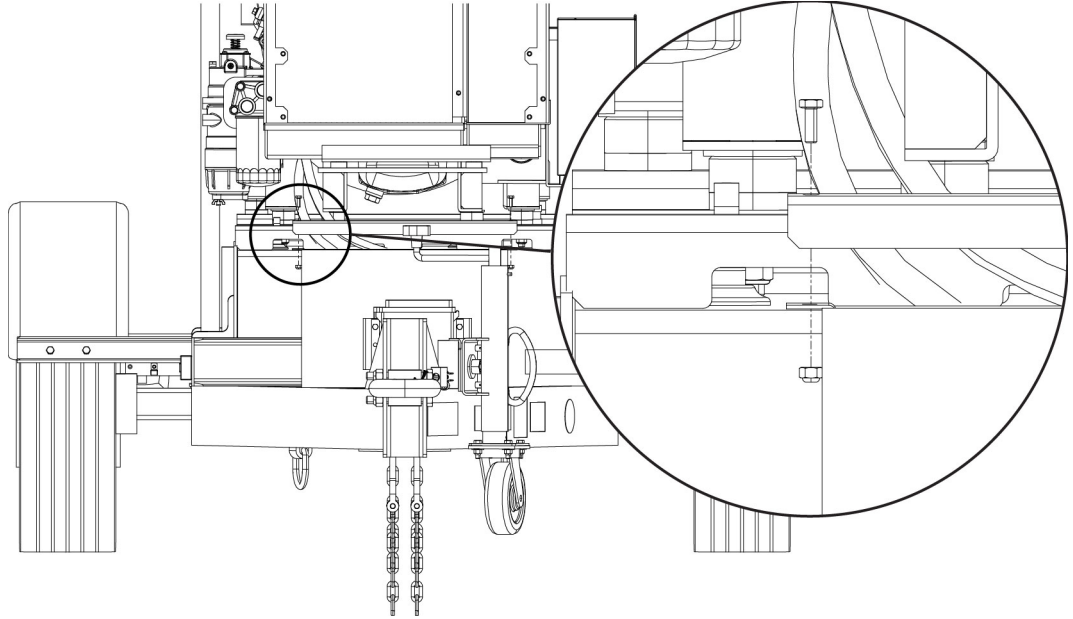

3. Disconnect the black cable from the negative battery terminal.



4. Disconnect the red cable from the positive battery terminal.
5. Secure the black cable to the red cable and position the cables away from the battery terminals.

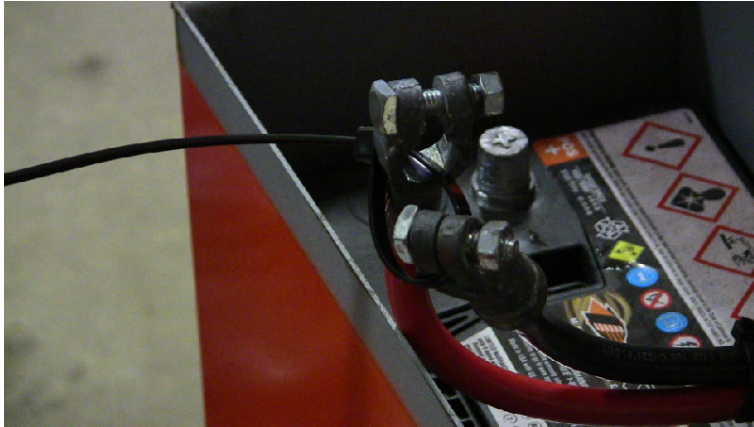

6.2.2 Remove the compressor belt guard

Remove the compressor belt guard to replace the belt or check belt tension.

1. Remove fasteners from the guard.

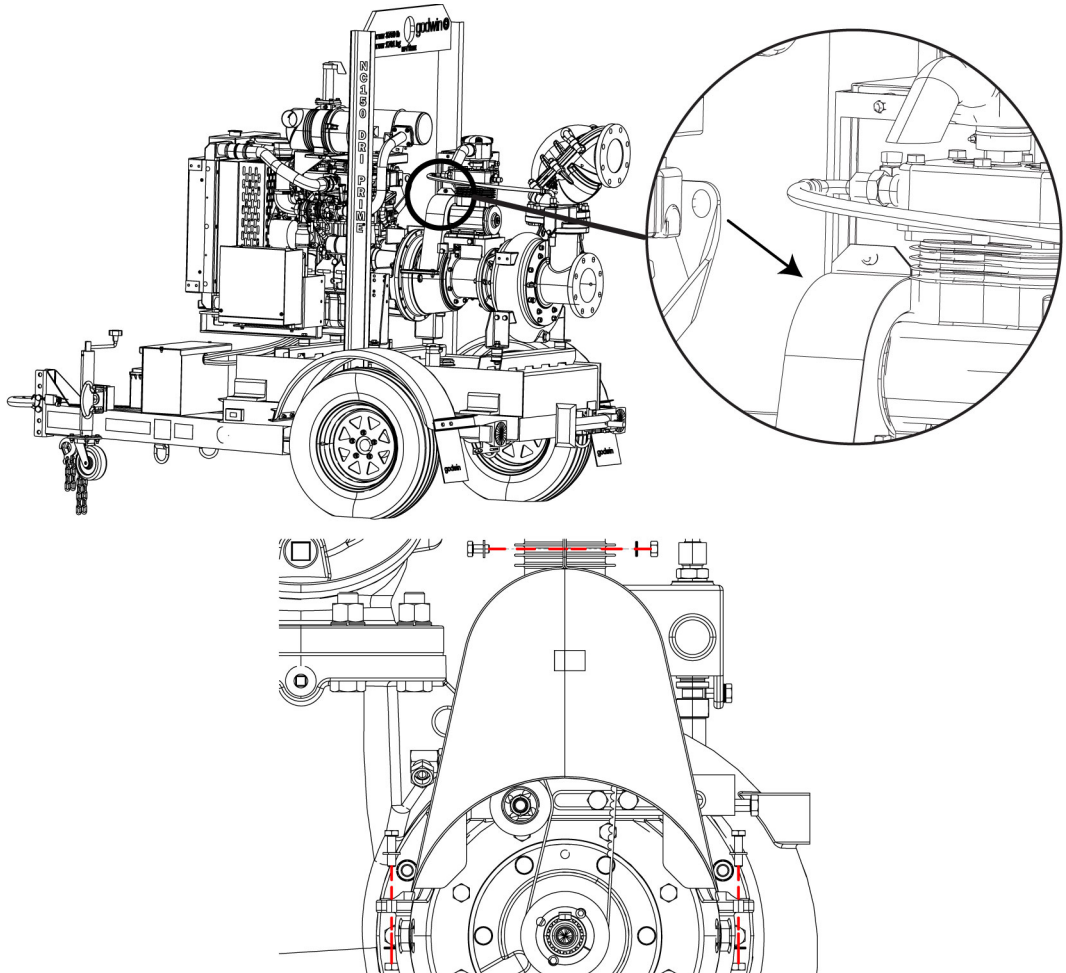

2. Remove the guard from the pump end.

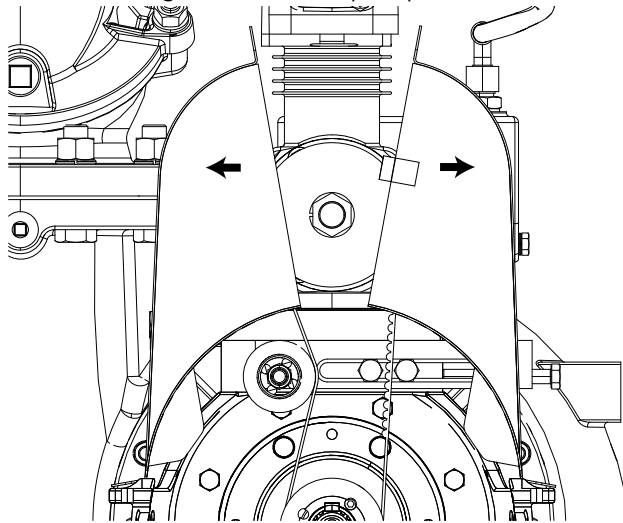

6.2.3 Disengage the coupling hub

1. Remove any rust or paint from the shaft.
2. Rotate the pump shaft until the socket head cap screw is accessible.

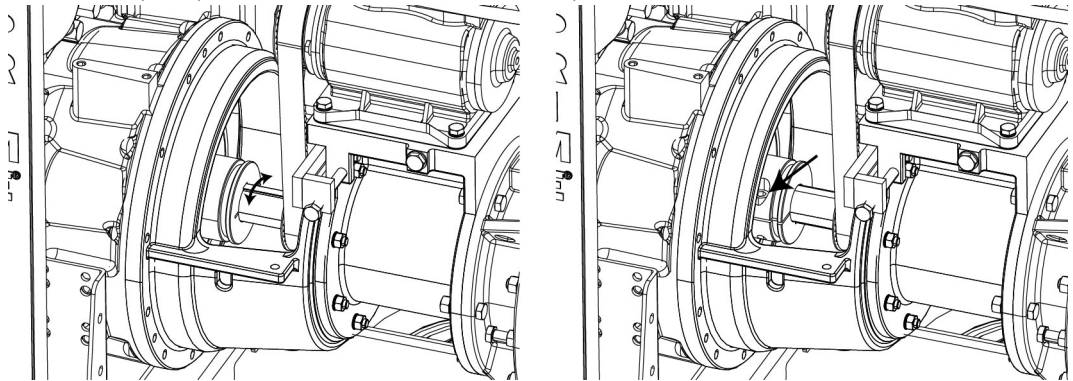

3. Loosen the socket head cap screw on the coupling hub.
Do not remove the socket head cap screw.
4. Rotate the pump shaft until the slot on the coupling hub is accessible.

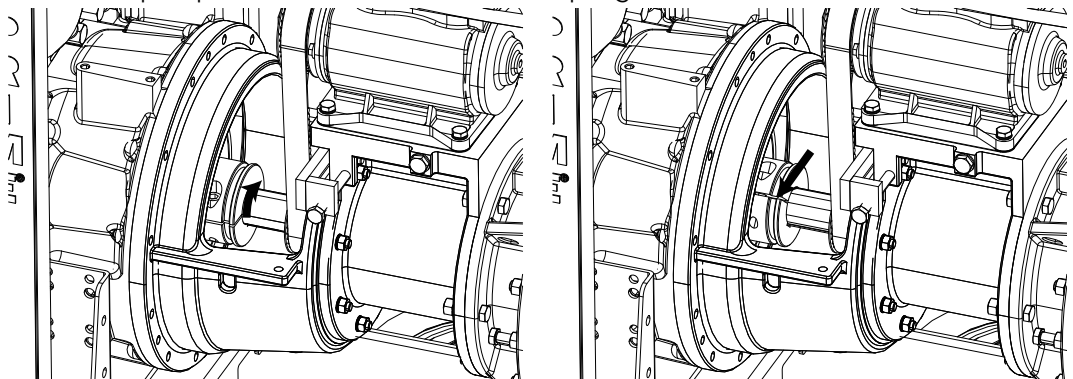

5. Insert a wedge into the slot located on the coupling hub.

6. Insert a pry bar into one of the motor adapter access holes.

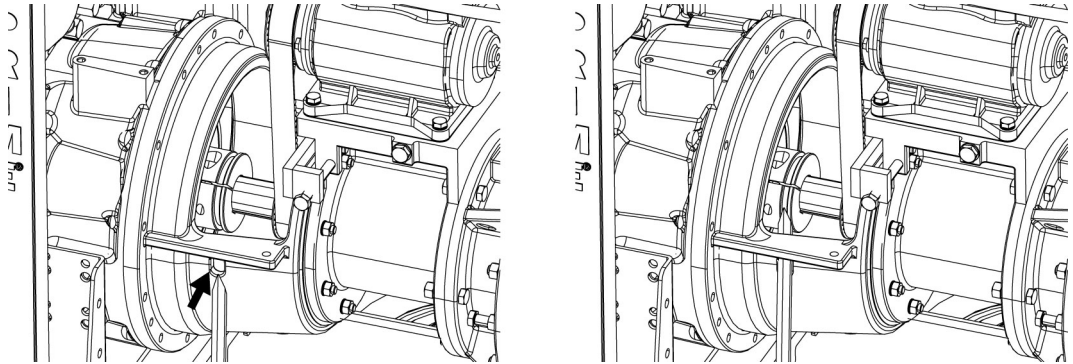

7. Add spray lubricant to shaft to help the coupling hub to slide along the shaft.
8. Slide the coupling hub toward the suction side of the pump end.

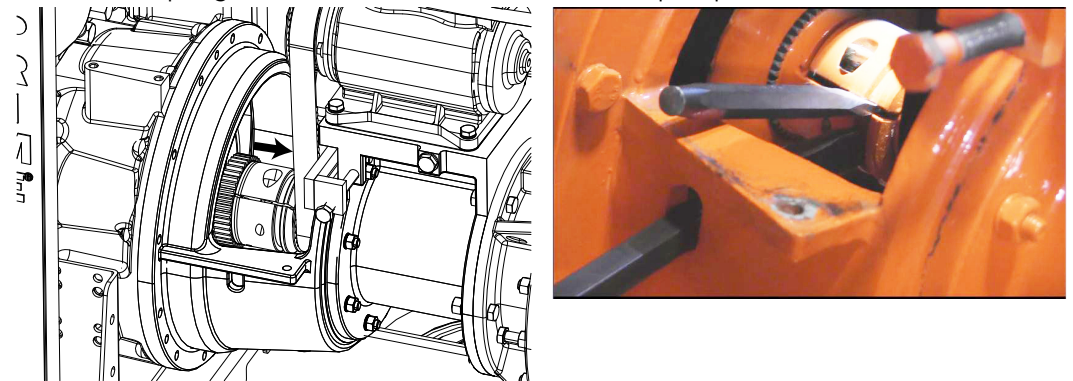

9. Remove the wedge from the coupling hub.

6.2.4 Remove the compressor belt

1. Loosen the fasteners that keep the tension arm in place.

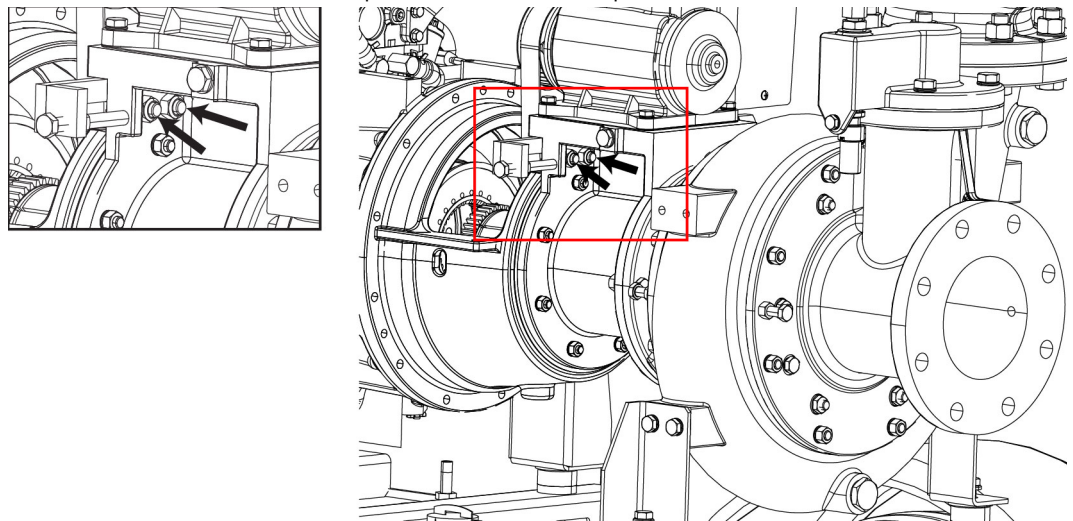

Do not over loosen the fasteners or remove them from the tension arm.

2. Loosen the tension arm bolt to loosen the belt.

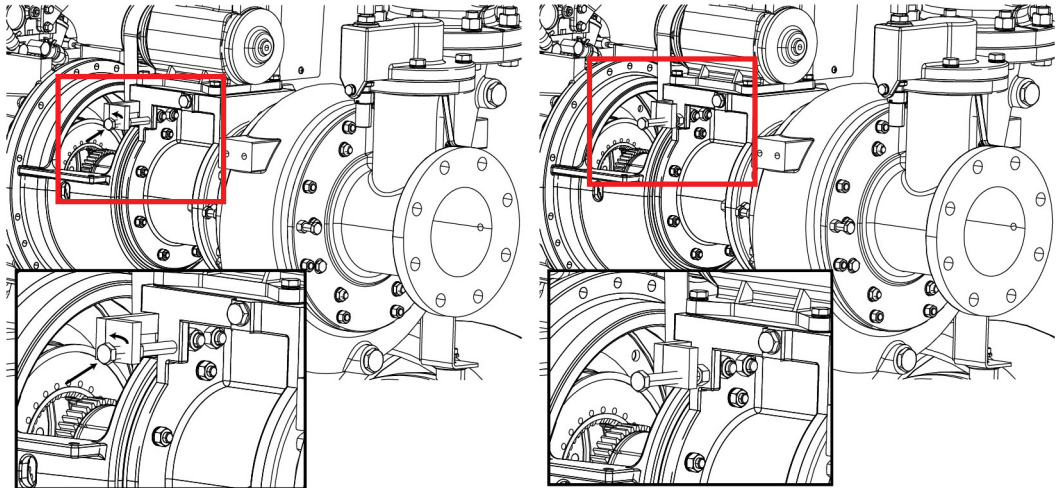

3. Push the compressor belt toward the drive end of the pump.

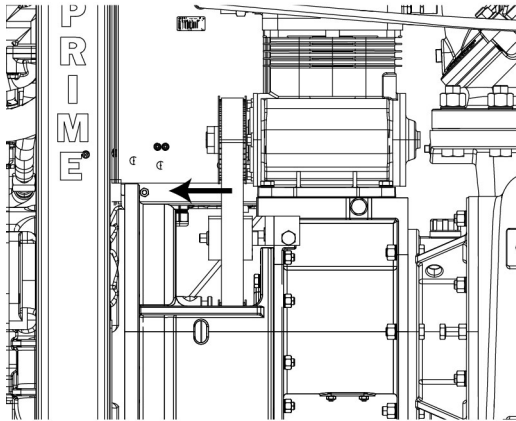

4. Rotate the compressor pulley to make the belt roll over the edge.

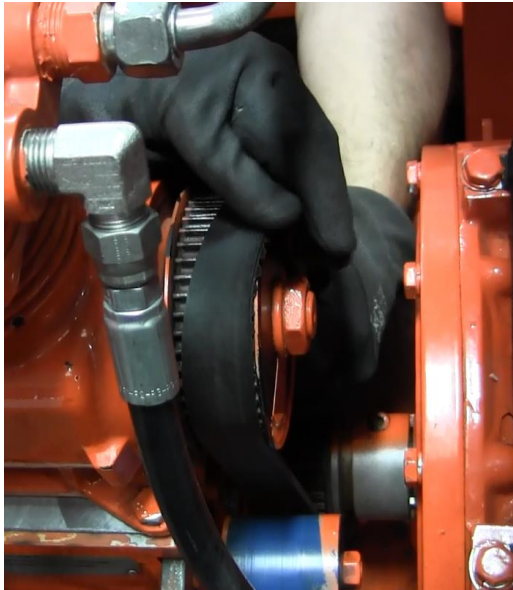

Do not place fingers in between the belt and pulley.

5. Slide the belt section around the pump shaft through the gap between the coupling flange and end of the pump shaft.

6.2.5 Install the compressor belt

1. Slide the belt section around the pump shaft through the gap between the coupling flange and end of the pump shaft.
2. Place the bottom section of the belt around the pulley located on the pump shaft.
3. Rotate the compressor pulley to make the belt roll over the edge and onto the pulley.

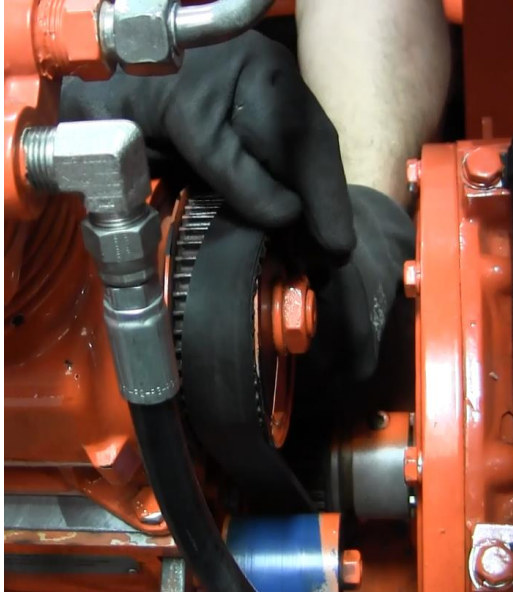

Do not place fingers in between the belt and pulley.

4. Tighten the tension arm bolt until the belt deflection matches the value found in the technical reference table.

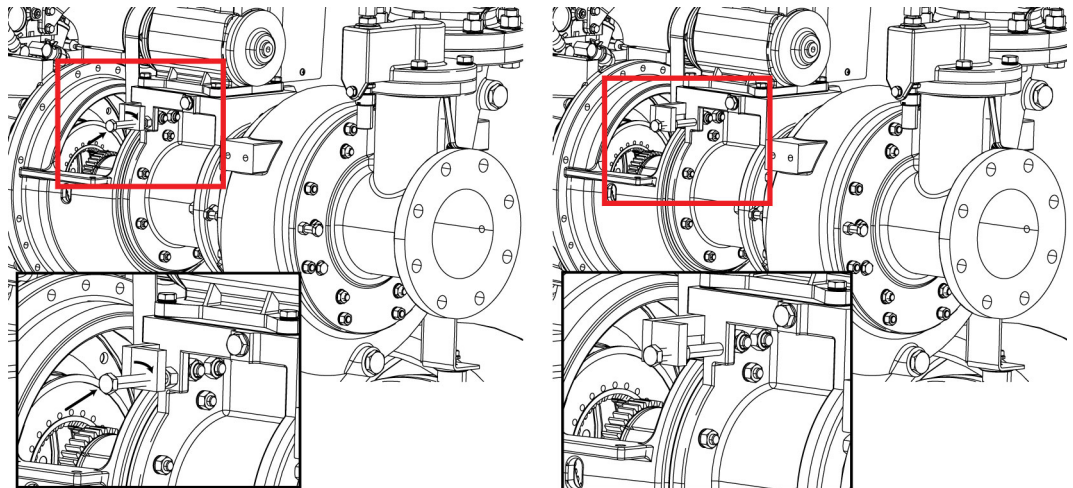

5. Tighten the fasteners that hold the tension arm in place.

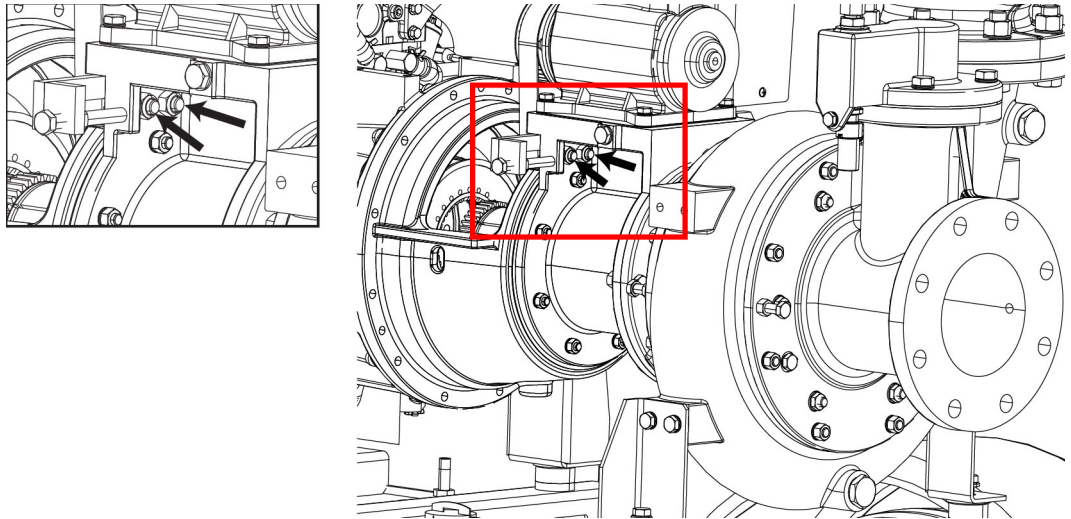

6.2.6 Install the coupling hub

1. Rotate the pump shaft until the slot on the coupling hub is accessible.

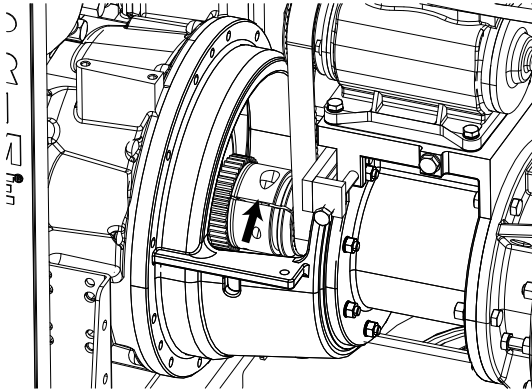

2. Insert a wedge into the slot located on the coupling hub.
3. Insert a pry bar into one of the motor adapter access holes.

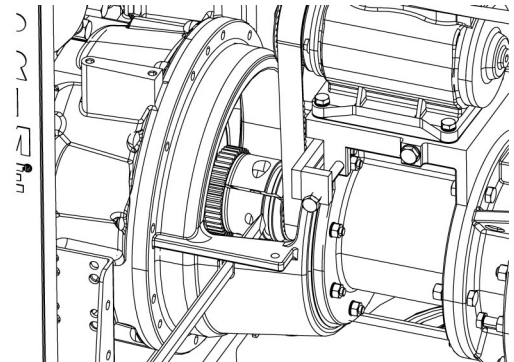
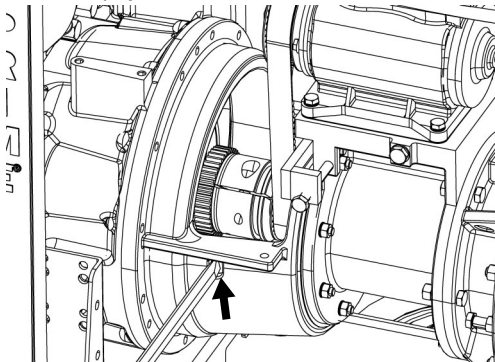

- Slide the coupling hub toward the drive side of the pump end.

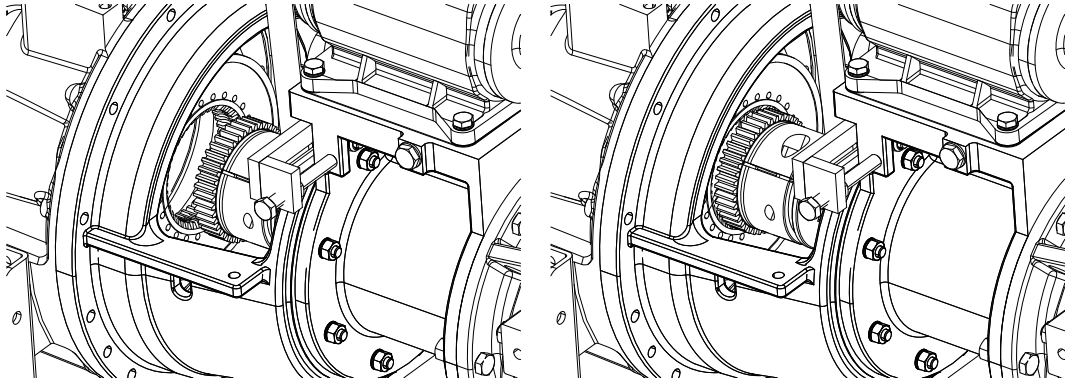

- Rotate the shaft to align coupling hub to the coupling flange.
- Insert the coupling hub into the coupling flange.

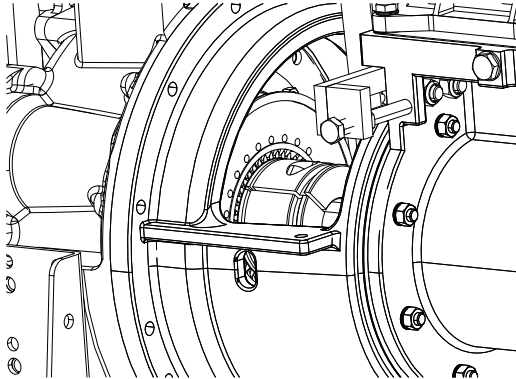

- Remove the wedge from the coupling hub.
- Rotate the pump shaft until the socket head cap screw is accessible.

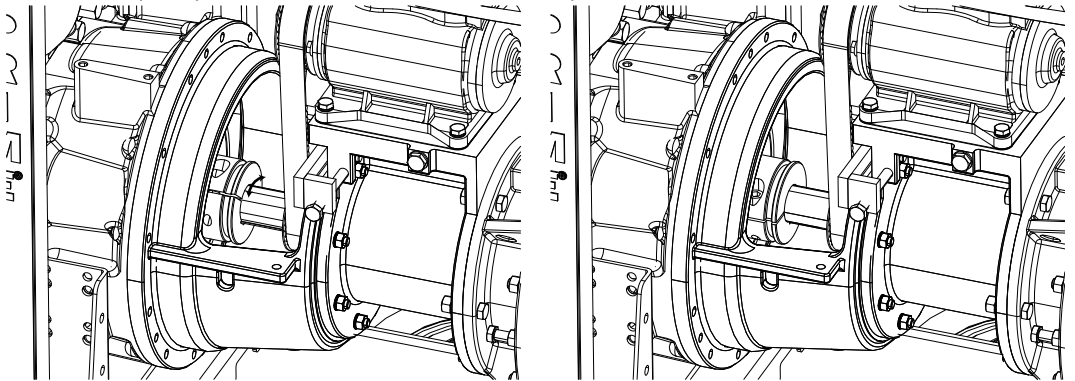

- Tighten the socket head cap screw on the coupling hub.
Suggested torque for this fastener is 86 Nm (63.4 ft-lb)

6.2.7 Install the compressor belt guard

Remove the compressor belt guard to replace the belt or check belt tension.

1.

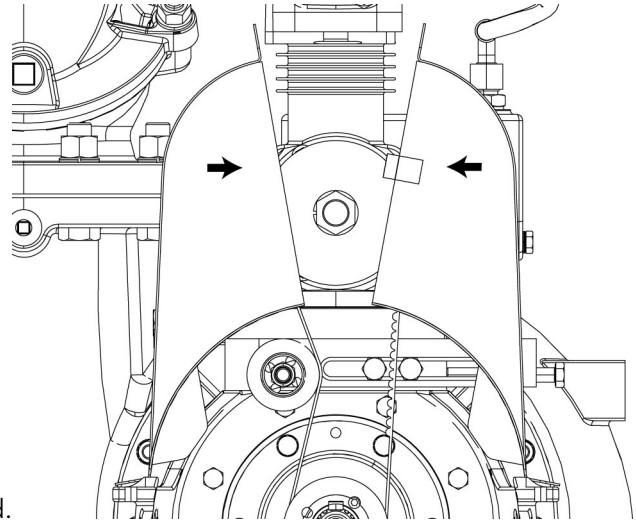

Install the guard on the pump end.

2. Install fasteners on the guard.

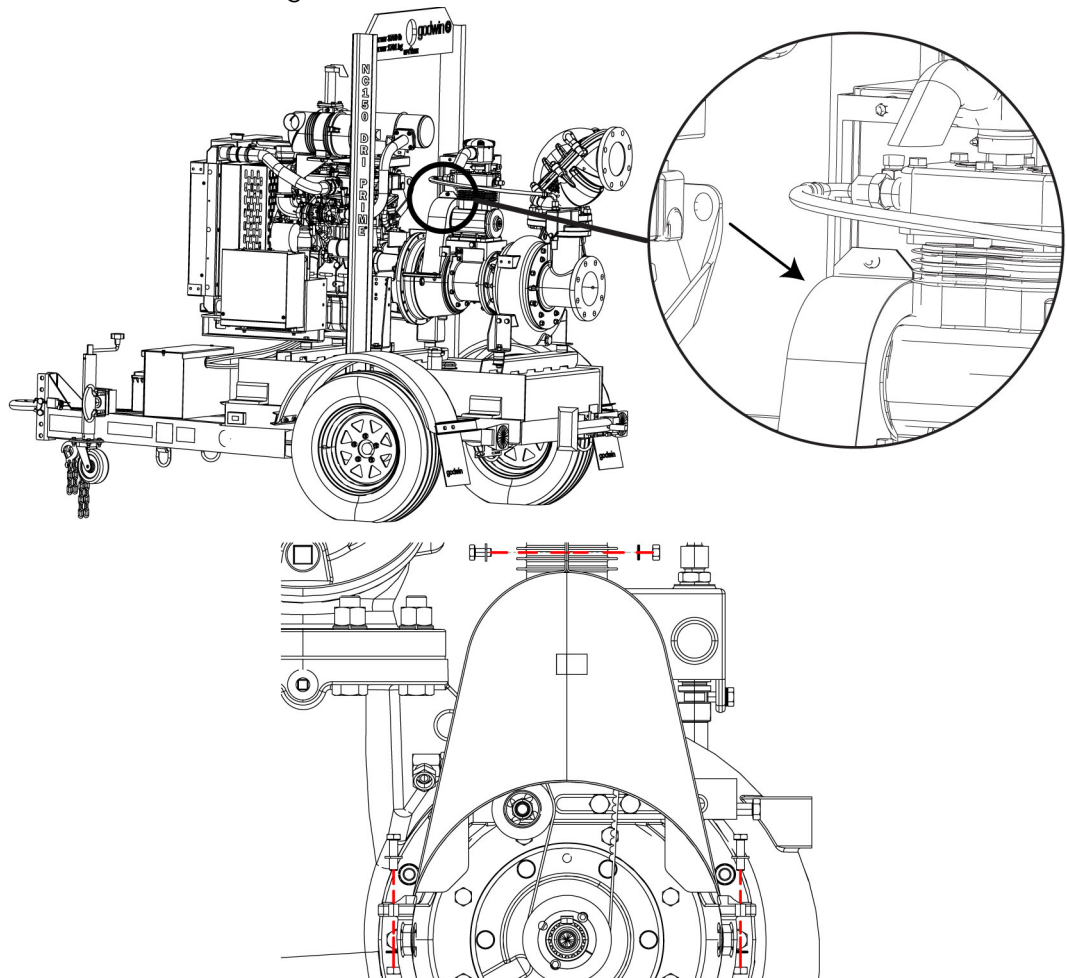

6.3 Daily maintenance

6.3.1 Engine maintenance

Perform the following on a daily basis before starting or operating the engine.

- Check the engine oil level. Verify that the level indication on the measuring stick is within the crosshatch pattern or at the "FULL" mark. If the oil level is low, then replenish with the correct engine oil.

Refer to the engine manufacturer's manual for the correct engine oil.

- Check the diesel fuel for the presence of water or contamination. If water or contamination is detected, then drain and clean the fuel tank. Otherwise, check the fuel level and replenish as necessary.
- Check the radiator coolant level after the engine has cooled.

6.3.2 Pump maintenance

- Check the coolant level in the mechanical seal. Replenish as necessary.
For required mechanical seal coolant, refer to [Technical Reference](#) on page 61.
- Check the position of the volute and the discharge non-return drain valves. Verify that the valves are closed before operation.

6.3.3 Acoustic enclosure maintenance

For units that are contained within an acoustic enclosure:

- Check the collection tank for the build-up of sediment and clean as necessary.
- Check the level of the bund tank. If full, then drain the bund before further operations.

6.3.4 Air compressor maintenance

- Check for any unusual noise or vibration.
- Conduct a visual inspection and ensure that all guards are in place.
- Check all pressurized components for rust, cracks, or leaks.
- Check for lubricant leaks.
- For air compressors utilizing an integral oil sump:
 - a) Maintain the oil level between the high and low marks on the dipstick.
 - b) Check the oil for any contamination. If contaminated, then drain and refill the compressor with an appropriate oil.

For recommended air compressor oil, refer to [Technical Reference](#) on page 61.

If any problems are discovered, then discontinue use of the equipment and consult your local Xylem representative.

6.3.5 Vacuum pump maintenance

- Check the oil level.
- Check for the feed of oil through the sight glass.
- Drain the moisture trap.

6.3.6 Gearbox maintenance

If the unit contains a gearbox, then perform the following on a daily basis before starting the unit.

- Check the gearbox oil level. Replenish the oil as necessary.

For recommended gearbox oil, refer to [Technical Reference](#) on page 61.

6.3.7 Ejector silencer maintenance

If the unit is fitted with an ejector silencer, then perform the following task on a daily basis.

- Check the ejector silencer tank for the build-up of sediment and clean as necessary.

Refer to the attached ejector silencer drawing for part descriptions and locations.

6.4 After the first 100 hours

6.4.1 Air compressor maintenance

If the unit contains an air compressor with an integral oil supply, then perform the following tasks after the first 100 hours of operation.

1. If the unit has recently been in operation, then allow the compressor to cool.
2. Drain the oil sump.
3. Fill the oil sump with a replacement lubricant.

For required lubricants and quantities, refer to [Technical Reference](#) on page 61.

6.5 After the first 200 hours

6.5.1 Gearbox maintenance

If the unit contains a gearbox, then perform the following tasks after the first 200 hours of operation.

1. Drain the oil from the gearbox.
2. Refill with the correct grade of oil.

For recommended gearbox oils, refer to [Coolants and lubricants](#) on page 61.

6.6 250 hour maintenance

6.6.1 Pump maintenance

1. Verify that the pump is powered off and all power is removed from the driver. If the driver is a diesel engine, then verify that the battery cables are disconnected from the battery and tied together
2. Drain any product from the pump by opening the volute and discharge non-return drain valves.

Drain fluids back into the source or into a spill container to be properly discarded.

3. Disconnect the pump from the suction and the discharge piping.
4. Inspect the pump and remove all dirt and debris. Visually inspect the volute from the suction flange for any obstructions and remove as needed.
5. Disconnect the ejector assembly and inspect for wear and the conditions of the O-rings and the nozzle. Remove the housing and check the condition of the ball, seat, and screen. Clean the screen of any dirt or debris.
6. Remove the discharge non-return valve inspection cover. Check the condition of the valve ball, seat, and O-ring seal. Replace the damaged parts as required.
7. Charge the bearing bracket with grease.

For greasing locations, refer to [Bearing lubrication](#) on page 33.

8. Connect power to the driver. If the driver is a diesel engine, then connect the ground cable to the negative battery terminal.
9. Record the serviced items and operation hours in a service log.

When all of the maintenance is completed, start the pump and perform a vacuum test as described in [Verify general operation](#) on page 20 section. Record the vacuum gauge readings in a service log as a reference.

6.6.2 Engine maintenance

Read the engine operation and maintenance manual for more detailed information about maintenance steps, maintenance intervals, and part location.

1. Shut down the engine.
2. Remove the battery cables from the terminals and tie the cables together.
3. Drain the engine oil and remove the old oil filter. To serve as a record for the next maintenance interval, write the current engine hour meter value on the new filter.

To drain the oil from a diesel engine that is contained within an acoustic enclosure and without an oil pan drain:

- a) Disconnect the oil return pipe from the base of the air compressor.
- b) Attach the pipe to the bottom of the sump pump.

c) Operate the pump until the engine sump is drained.

d) Reconnect the oil return pipe to the air compressor.

For the correct oil and quantity, refer to the engine manufacturer's manual.

4. Check for the correct engine coolant level and concentration. Refill as necessary. Brush away any accumulated dirt and debris from the radiator coils.

For the correct coolant and quantity, refer to the engine manufacturer's manual.

5. To replace the engine fuel filter, drain and remove the existing filter and install a replacement. Bleed the fuel system of air and prime the fuel pump.
6. Inspect the engine air cleaner for excessive dirt. Replace as required.
7. Inspect all of the hoses, wiring, and connections around the engine. Correct as required.
8. Check the tension and the condition of the engine fan belt. Adjust or replace as necessary.
For the correct tension of the fan belt, refer to the engine manual.
9. Ensure that the fuel cap is secured tightly and all of the mounting bolts are tightly fastened.
10. If the unit contains a lead acid battery, then check the battery electrolyte level. Replenish to the correct level.

6.6.3 Motor maintenance

1. Verify that the motor is powered off and all power sources are removed.
2. Check that the interior and exterior of the motor is free of dirt, oil, grease, water, and other matter. Oily vapor, paper pulp, textile lint, and other debris accumulate then block the motor ventilation. If the motor is not properly ventilated, then overheating occurs and causes early failure.
3. Check all combinations phase to phase with a continuity meter. Any variance of 10% or greater please contact your local Xylem office.
4. Measure the motor winding insulation resistance of each phase with a mega-ohm meter. Record the readings on a service log. Compare the readings of each phase. If the readings are markedly different, then contact your local Xylem representative.
Mega ohm reading are taken phase to ground and should read infinite. Any reading below 20M Ω please contact a licensed electrician to inspect the insulation.
5. Ensure that all electrical connectors are in place and secured.
6. Record the serviced items and operation hours in a service log.

6.6.4 Air compressor maintenance

- Inspect the compressor oil lines, air lines, and other connections.
- Examine the compressor air filter for excessive dirt. Replace the filter as required.
- If the compressor is external to the driver, then check the drive belt condition and tension. Adjust the drive belt tension or replace as necessary.
 - For tension values, refer to [Technical Reference](#) on page 61.
 - To adjust the drive belt tension, refer to [Technical Reference](#) on page 61.
 - To replace the belt refer to the appropriate service manual, available from your local Xylem representative.

6.6.5 Vacuum pump maintenance

- Check the tension and the condition of the drive belt. Adjust the tension or replace as necessary.
 - For tension values, refer to [Technical Reference](#) on page 61.
 - To adjust the drive belt tension, refer to [Technical Reference](#) on page 61.
 - To replace the belt refer to the appropriate service manual, available from your local Xylem representative.

6.7 500 hour maintenance

6.7.1 Air compressor

If the unit contains an air compressor with an integral oil supply, then perform the following tasks.

- Change the lubricant.
In harsh environments, change the lubricant more frequently.
For required lubricants and quantities, refer to [Technical Reference](#) on page 61.
- Change the air filter.
In harsh environments, change the air filter more frequently.
- Tighten the pulley clamp screws.

6.7.2 Vacuum pump maintenance

- Check the condition of the air filter. Replace as necessary.
To replace the air filter refer to the appropriate service manual, available from your local Xylem representative.
- Change the oil cooler filter.
To replace the oil cooler filter, refer to the appropriate service manual, available from your local Xylem representative.
- Inspect the float assembly and associated shaft bearings for wear and damage.
Replace as necessary.
To replace components of the float assembly or associated shaft bearings, refer to the appropriate service manual, available from your local Xylem representative.

6.8 1000 hour maintenance

6.8.1 Air compressor

- Change the air filter.
In harsh environments, change the air filter more frequently.
- Inspect the air compressor valves for any leakage or the build-up of carbon. Clean and replace as necessary.
- If the air compressor contains an integral oil supply, then clean the oil sump strainer screen. If necessary, clean the oil sump.
To remove and clean the oil sump strainer screen, refer to the air compressor manual.

6.8.2 Vacuum pump maintenance

- Change the vacuum pump oil.
For recommended vacuum pump oil, refer to [Technical Reference](#) on page 61.
- Change the exhaust smoke eliminator filter.
If the back pressure exceeds 3 psi above the nominal running pressure (0.5-1.0 psi), the filter must be replaced, regardless of elapsed time.
To replace the smoke eliminator filter refer to the appropriate service manual, available from your local Xylem representative.

6.8.3 Gearbox maintenance

If the unit contains a gearbox, then perform the following tasks every 1000 hours.

1. Drain the oil from the gearbox.
2. Refill with the correct oil.
For recommended gearbox oils, refer to [Technical Reference](#) on page 61.

6.9 2000 hour maintenance

6.9.1 Air compressor

If the unit contains an air compressor with an integral oil supply, then perform the following tasks.

- Check the pressure switch diaphragm and the contacts for any damage or excessive wear. Replace or repair as necessary.
- Check the contact points in the motor and the starter for any damage or excessive wear. Replace or repair as necessary.

6.10 5000 hour maintenance

6.10.1 Pump maintenance

- Inspect the mechanical seal for excessive wear and damage. Replace as necessary.
To replace the mechanical seal, refer to the appropriate service manual, available from your local Xylem representative.
- Inspect the bearings for excessive wear and damage. Replace as necessary.
To replace the bearings, refer to the appropriate service manual, available from your local Xylem representative.
- Check the clearance between the insert ring and the impeller. If the correct clearance cannot be achieved, then check the parts for wear and damage. Replace as necessary.
For the required clearance, refer to [Impeller to wear plate clearances](#) on page 65.
To check the clearance between the impeller and the front wear plate, refer to the appropriate service manual, available from your local Xylem representative.
- Inspect the shaft and the related seals for wear and damage. Replace as necessary.
To replace the shaft and the related seals, refer to the appropriate service manual, available from your local Xylem representative.

6.11 Trailer maintenance

6.11.1 Before each journey

Perform the following tasks before each journey.

- Check the trailer, tires, and wheels visually for any damage. Replace any damaged components.
If the wheel is damaged, then check the brake drum and the axles for any damage.
- Check the wheel nuts or bolts. Tighten as necessary.
- Check the connection to towing vehicle.
To check the coupling for excessive movement, move the towing eye or ball, by hand, backwards and forwards, up and down. Replace any damaged parts.
- Check tire pressures.
- To check the operation and effectiveness of the handbrake, apply the handbrake in safe conditions. If the handbrake is ineffective, then adjust the braking system.
To adjust the braking system, refer to the appropriate service manual, available from your local Xylem representative.
- Check the lights. Replace any inoperable bulbs and damaged lenses.
- If fitted, ensure adequate lubrication of the 50 mm ball head.

6.11.2 After every 500 miles

Perform the following tasks after every 500 miles traveled or every month.

- Check the brakes. Adjust the brakes as necessary.

To adjust the brakes, refer to the appropriate service manual, available from your local Xylem representative.

- Check the wheel hubs for side play. Replace any damaged components.

6.11.3 After every 6000 miles

Perform the following task after every 6000 miles traveled or every six months.

- Apply grease to the over-run coupling greasing points.

6.11.4 After every 12000 miles

Perform the following tasks after every 12000 miles traveled or every 12 months.

- Check the jockey wheel and the prop stands for any damage. Replace as necessary.
- Lubricate the jockey wheel and the prop stands.
- Clean, inspect, and grease all joints. Replace damaged components as necessary.

6.11.5 After every 24000 miles

Perform the following task after every 24000 miles traveled or every 24 months.

- Clean, inspect, and grease wheel hub bearings. Replace any damaged components.

7 Troubleshooting

7.1 Troubleshooting precautions



DANGER:

Electrical hazard sufficient to kill. Always disconnect and lock out the power before you service the unit.



WARNING:

- Pressurized device. Make sure that the internal pressure is relieved before you continue.
 - Compressed Gas Hazard. Never apply a pressure to any cavity or chamber in the product to test for leakage. Pressurized air may cause parts to be propelled with force. Overpressurization can cause structural failure.
 - Make sure that the pump is isolated from the system and that pressure is relieved before you disassemble the pump, remove plugs, open vent or drain valves, or disconnect the piping.
 - Maintenance and service must be performed by skilled and qualified personnel only.
-



CAUTION:

Allow all system and pump components to cool before you handle them to prevent physical injury.

- Read all operation and maintenance manuals supplied with the unit.

7.2 Troubleshooting – Pump

Table 1: Pump does not prime

Possible cause	Remedy
The pump does not create a vacuum.	Perform a vacuum pad test. If no vacuum is present, then check all possible causes for the fault. If an issue persists, then contact your local Xylem representative. See Verify general operation on page 20.
The suction lift is too great.	Check the vertical distance to the source. If greater than 8.5 m (28 ft), then move the pump closer to the source.
There is insufficient liquid at the suction inlet.	Check the amount of liquid at the source. If the source has been drained, then move the pump to a new liquid source.
The suction inlet or the strainer is blocked.	Check the inlet or the strainer for any blockage, clean as necessary.
The separation tank filter is blocked. Refer to the attached hydraulic end drawing for part descriptions and locations.	Check the separation tank filter for any blockage, clean as necessary.
The suction line is not air-tight.	Check for leaks along the suction line. Tighten the joints between sections of piping and replace any damaged piping.
The suction pipe has collapsed.	Check the suction line for collapsed points. If the pipe has collapsed, then contact your local Xylem representative for product support. Do not run the pump.

Possible cause	Remedy
The non-return valve does not seat.	Check for any blockage or damage. Clear any blockage and replace any damaged parts.
The mechanical seal draws air into the pump.	Check for a continuous drop in the level of mechanical seal coolant. If the level continually drops, then replace the mechanical seal. To replace the mechanical seal, refer to the appropriate service manual available from your local Xylem representative.
Compressor units only: the ejector jet or the nozzle is blocked or damaged. Refer to the attached ejector package drawing for part descriptions and locations.	Check the ejector jet and nozzle for any blockage and damage, clear any blockage and replace any damaged parts.
Compressor units only: the ejector non-return valve ball is stuck. Refer to the attached ejector package drawing for part descriptions and locations.	Check the ejector non-return valve ball and seat for any blockage or damage. Clear any blockage and replace any damaged parts.
Compressor units only: compressor pipe leaks air.	Check the compressor pipe for leaks. Replace as necessary.
Compressor units only: compressor does not deliver enough air.	Check all other possible causes. If the issue persists, then contact your local Xylem representative for product support.
The compressor or the vacuum pump drive belt is faulty.	Check the belt for excessive wear or damage. Replace as necessary. To replace the drive belt, refer to the appropriate service manual, available from your local Xylem representative.
The speed of the driver is incorrect.	Compare the driver speed with the driver speed given on the pump curve. Adjust the driver to the correct speed. Do not operate the pump outside of the limits that are given in Designations, sizes, and capacities on page 61.

Table 2: Insufficient liquid is delivered

Possible cause	Remedy
The pump does not create a vacuum.	Perform a vacuum pad test. If no vacuum is present, then check all possible causes for the fault. If the issue persists, then contact your local Xylem representative. See Verify general operation on page 20.
The suction lift is too great.	Check the vertical distance to the source. If greater than 8.5 m (28 ft), then move the pump closer to the source.
The suction inlet or the strainer is blocked.	Check the inlet or the strainer for any blockage, clean as necessary.
The separation tank filter is blocked. Refer to the attached hydraulic end drawing for part descriptions and locations.	Check the separation tank filter for any blockage, clean as necessary.
The suction line is not air-tight.	Check for leaks along the suction line. Tighten the joints between sections of piping and replace any damaged piping.
The suction pipe has collapsed.	Check the suction line for collapsed points. If the pipe has collapsed, then contact your local Xylem representative for product support. Do not run the pump.
The mechanical seal draws air into the pump.	Check for a continuous drop in the level of mechanical seal coolant. If the level continually drops, then replace the mechanical seal. To replace the mechanical seal, refer to the appropriate service manual available from your local Xylem representative.

Possible cause	Remedy
The discharge head is too high.	Check the length of the discharge line. If the length is greater than the maximum head of the pump, then reduce the length of the discharge line.
There is an obstruction in the volute or the impeller.	Remove the front cover and check the volute and impeller for obstructions, clear as necessary.
The impeller is excessively worn or damaged.	Check the impeller for any damage or excessive wear, replace as necessary.
The delivery line leaks or is blocked.	Check the line for leaks or blockage, replace damaged pipe and clear any blockage.
The speed of the driver is incorrect.	Compare the driver speed with the driver speed given on the pump curve. Adjust the driver to the correct speed. Do not operate the pump outside of the limits that are given in <i>Designations, sizes, and capacities</i> on page 61.
Electric motor driven units only: the motor rotates in the incorrect direction.	Check the motor rotation against the directional arrow on the electric motor. If the rotation is incorrect, reverse the polarity of the electric motor.

Table 3: Liquid flow ceases

Possible cause	Remedy
The pump does not create a vacuum.	Perform a vacuum pad test. If no vacuum is present, then check all possible causes for the fault. If the issue persists, then contact your local Xylem representative. See <i>Verify general operation</i> on page 20.
The suction lift is too great.	Check the vertical distance to the source. If greater than 8.5 m (28 ft), then move the pump closer to the source.
There is insufficient liquid at the suction inlet.	Check the amount of liquid at the source. If the source has been drained, then move the pump to a new liquid source.
The suction inlet or the strainer is blocked.	Check the inlet or the strainer for any blockage, clean as necessary.
The separation tank filter is blocked. Refer to the attached hydraulic end drawing for part descriptions and locations.	Check the separation tank filter for any blockage, clean as necessary.
The suction line is not air-tight.	Check for leaks along the suction line. Tighten the joints between sections of piping and replace any damaged piping.
The suction pipe has collapsed.	Check the suction line for collapsed points. If the pipe has collapsed, then contact your local Xylem representative for product support. Do not run the pump.
The mechanical seal draws air into the pump.	Check for a continuous drop in the level of mechanical seal coolant. If the level continually drops, then replace the mechanical seal. To replace the mechanical seal, refer to the appropriate service manual available from your local Xylem representative.
Compressor units only: the ejector jet or the nozzle is blocked or damaged. Refer to the attached ejector package drawing for part descriptions and locations.	Check the ejector jet and nozzle for any blockage and damage, clear any blockage and replace any damaged parts.
There is an obstruction in the volute or the impeller.	Remove the front cover and check the volute and impeller for obstructions, clear as necessary.
The impeller is excessively worn or damaged	Check the impeller for any damage or excessive wear, replace as necessary.

Possible cause	Remedy
The delivery line leaks or is blocked.	Check the line for leaks or blockage, replace damaged pipe and clear any blockage.

Table 4: The unit vibrates or overheats

Possible cause	Remedy
The suction inlet or the strainer is blocked.	Check the inlet or the strainer for any blockage, clean as necessary.
The discharge head is too high.	Check the length of the discharge line. If the length is greater than the maximum head of the pump, then reduce the length of the discharge line.
There is an obstruction in the volute or the impeller.	Remove the front cover and check the volute and impeller for obstructions, clear as necessary.
The impeller is excessively worn or damaged.	Check the impeller for any damage or excessive wear, replace as necessary.
The delivery line leaks or is blocked.	Check the line for leaks or blockage, replace damaged pipe and clear any blockage.
The speed of the driver is incorrect.	Compare the driver speed with the driver speed given on the pump curve. Adjust the driver to the correct speed. Do not operate the pump outside of the limits that are given in Designations, sizes, and capacities on page 61.
The pump exhibits cavitation	If the pump sounds like it is pumping rocks, then ensure that the pump operates within the recommended limits. If the issue persists, then contact your local Xylem representative for product support.
The pump does not operate at the best efficiency point.	Check the vacuum and pressure gauges. Compare the readouts with the applicable pump curve. To operate the pump at the best efficiency point, adjust the speed of the engine or the diameter of the lines. For further information, contact your local Xylem representative.
The base is not properly secured.	Check the mounting bolts, tighten as necessary.
The pump and driver are misaligned.	Check the alignment of the pump to the driver. If the coupling is misaligned, then align the pump to the driver. See Pump-to-driver alignment instructions on page 29.
The coupling is damaged or excessively worn.	Check the coupling for any damage and excessive wear, replace as necessary.

Table 5: The mechanical seal coolant is emulsified

Possible cause	Remedy
The mechanical seal is damaged or excessively worn.	Drain the coolant bath and check for any damage and excessive wear. Replace as necessary.

7.3 Troubleshooting – Driver

Table 6: The driver exhibits excessive power consumption

Possible cause	Remedy
There is an obstruction in the volute or the impeller.	Remove the front cover and check the volute and impeller for obstructions, clear as necessary.
The viscosity or specific gravity of the liquid is too high.	Check the viscosity or the specific gravity of the liquid. Compare with water. If higher than water, then contact your local Xylem representative.

Table 7: The driver does not start

Possible cause	Remedy
The emergency stop is engaged.	Disengage the emergency stop.
Diesel engine driven units only: the level of fuel is too low.	Check the fuel gauge and fill as needed.
Diesel engine driven units only: the fuel filter is blocked.	Check the fuel filter for a blockage, clean or replace as necessary.
Diesel engine driven units only: the oil pressure is too low.	Check the oil level and add as needed. See the engine manual for the correct oil grade and quantity.
Diesel engine driven units only: the fuel check valve is blocked or damaged.	Inspect the fuel check valve for a blockage and damage, clean or replace as necessary.
Diesel engine driven units only: the battery cables are disconnected.	Check the battery cable connections, reconnect if necessary.
Diesel engine driven units only: there is water in the fuel.	Test the fuel for water. If water is present, then drain the tank and refill.

7.4 Troubleshooting – Trailer

Table 8: – Braking is one-sided

Possible cause	Remedy
The brakes are adjusted unevenly.	Check the brakes. To even the braking, adjust the appropriate brake or brakes. To adjust the brakes, refer to the appropriate service manual available from your local Xylem representative.
The brake cable has seized.	Check the brake cable, attempt to release the cable. If the cable remains seized, then remove and replace the cable.
The brake lining is contaminated with grease.	Check the brake lining. If the brake lining is contaminated, then replace the lining.

Table 9: – Braking occurs during mild deceleration

Possible cause	Remedy
The coupling damper is weak or ineffective.	To check the coupling damper for weakness or ineffectiveness, by hand, pull the coupling out and then push it in. If the coupling slides back with little to no resistance, then replace the coupling damper. If the coupling exhibits some resistance to the motion, then check other possible causes.
The brakes have been over adjusted.	Check the brakes, readjust as necessary. To adjust the brakes, refer to the appropriate service manual available from your local Xylem representative.

Table 10: – The trailer brakes snatch when braking

Possible cause	Remedy
The brakes have been over adjusted.	Check the brakes, readjust as necessary. To to adjust the brakes, refer to the appropriate service manual available from your local Xylem representative.
The brake cable sticks.	Check the brake cable, attempt to release the cable. If the cable remains seized, then remove and replace the cable.
The brakes have been under-adjusted	Check the brakes, readjust as necessary. To adjust the brakes, refer to the appropriate service manual available from your local Xylem representative.

Possible cause	Remedy
The coupling damper is weak or ineffective.	To check the coupling damper for weakness or ineffectiveness, by hand, pull the coupling out and then push it in. If the coupling slides back with little to no resistance, then replace the coupling damper. If the coupling exhibits some resistance to the motion, then check other possible causes.
The drawtube sticks.	Check the drawtube over the full stroke. Lubricate if necessary.

Table 11: – The brakes vibrate

Possible cause	Remedy
The brake lining is contaminated with grease.	Check the brake lining. If the brake lining is contaminated, then replace the lining.
Failure of the bond between brake lining and shoe.	Inspect the shoe and replace if necessary. If fitted with an emergency brake, then check the brake cable and attempt to release the cable. If the cable remains seized, then remove and replace the cable.
The brake drum is distorted or cracked.	Check each brake drum for distortion and damage. Replace as necessary.
The brake drums have rusty patches on the braking surface.	Check each brake drum for patches of rust. Remove the patches of rust with abrasive paper and clean the brake drum.

Table 12: – The trailer brakes lock up when reversing

Possible cause	Remedy
The brakes are over-adjusted.	Check the brakes, readjust as necessary. To adjust the brakes, refer to the appropriate service manual available from your local Xylem representative.
Incompatibility between the coupling and the brakes.	Check the other possible causes. If the problem persists, then contact your local Xylem representative.

Table 13: – The trailer brakes are inoperative

Possible cause	Remedy
The brakes are under-adjusted.	Check the brakes, readjust as necessary. To adjust the brakes, refer to the appropriate service manual available from your local Xylem representative.
The brake lining is contaminated with grease.	Check the brake lining. If the brake lining is contaminated, then replace the lining.
The brake cable has seized.	Check the brake cable, attempt to release the cable. If the cable remains seized, then remove and replace the cable.
The brake linings are excessively worn.	Check the brake linings for excessive wear, replace as necessary.

Table 14: – The brakes quickly become hot

Possible cause	Remedy
The brakes are over-adjusted.	Check the brakes, readjust as necessary. To adjust the brakes, refer to the appropriate service manual available from your local Xylem representative..
The pull off strings are over stretched or damaged.	Check the springs for distortion and damage, replace as necessary.
The brake cable has seized.	Check the brake cable, attempt to release the cable. If the cable remains seized, then remove and replace the cable.

Table 15: The handbrake does not hold the trailer on a slope

Possible cause	Remedy
The brakes are under-adjusted.	Check the brakes, readjust as necessary. To adjust the brakes, refer to the appropriate service manual available from your local Xylem representative.
The spring store has been incorrectly set.	Check the spring store, readjust as necessary.

8 Technical Reference

8.1 Designations, sizes, and capacities

Pump type	Maximum flow	Maximum working temperature	Maximum pressure	Minimum speed (rpm)	Normal speed (rpm)	Maximum speed (rpm)
NC80	118 m ³ /hr (520 US gpm)	80 °C (176 °F)	3.3 bar (48 psi)	1200	1800	2200
NC100	242 m ³ /hr (1070 US gpm)	80 °C (176 °F)	4.9 bar (71 psi)	1200	1800	2200
NC150	403 m ³ /hr (1770 US gpm)	80 °C (176 °F)	6.2 bar (90 psi)	1200	1800	2200
NC150S	300 m ³ /hr (1320 US gpm)	80 °C (176 °F)	6.0 bar (87 psi)	1200	1800	2200
NC350	1484 m ³ /hr (6530 US gpm)	80 °C (176 °F)	4.9 bar (71 psi)	900	1100	1200

8.2 Coolants and lubricants

Air compressor lubricant

Table 16: Oil requirements for each class of compressor with an integral oil sump

Compressor	Oil capacity	Required oil
Quincy 216	1.42 L (0.375 US gal)	Quin-Cip SAE 20W, ISO 68, SAE 15W40, or equivalent
Quincy 240	1.42 L (0.375 US gal)	Quin-Cip SAE 20W, ISO 68, SAE 15W40, or equivalent
Quincy 270	4.50 L (1.18 US gal)	Quin-Cip SAE 20W, ISO 68, SAE 15W40, or equivalent

Bearing lubricant

Choose a grease from the following list. Do not mix greases from a different manufacturer. Consult Xylem representative before adding a different grease to the bearings.

- Texaco Starplex EP2 – Factory lubricant
- Belesta XPG
- Mobil SHC 46
- Shell Nertia HV
- Total Multis Complex EP2
- Valvoline NLGI #2 Bearing and Chassis Lubricant

Mechanical seal coolant

Table 17: Required coolant types and quantity

Pump model	Coolant capacity	Coolant
NC80, NC100, NC150	1.0 L (0.26 US gal)	Oil. Any SAE 20/20 or BIOPUS 46 Biodegradable.
NC350	13.9 L (3.7 US gal)	
NC150S	0.75 L (0.2 US gal)	ISO 68 Biodegradable oil or Water and glycol mixture (50/50)

Vacuum pump lubricant

Table 18: Recommended vacuum pump oil

Operation environment	Recommended oil
Ambient temperature below 0°C (32°F)	Amocon 32 Shell Turbo T Oil 32 Mobil SHC 524 or 525 Monolec Compressor Oil 6401 or 6402 Chevron GST 46 Pennzbell T Oil 32 or 46 Regal Oil R & O 32
Ambient temperature above 0°C (32°F)	Amocon 68 Shell Turbo T Oil 68 or 100 Mobil SHC 526 or 527 Monolec Compressor Oil 6403 or 6404 Anderol 497 Chevron GST 68 Pennzbell T Oil 68 Regal Oil R & O 68

Gearbox lubricant

To lubricate the gearbox, use one of the following:

- Mobil Mobilube HD90
- Shell Spirax 90
- BP Gear Oil SAE90EP
- Esso Gear Oil GX90

8.3 Torque values

Spanner torques

These tables provide the recommended torque values required to tighten general-purpose metric and UNC fasteners.

NOTICE:

- These values are only applicable for joints that are metal to metal, without gaskets.
- Do not use these figures for fasteners, such as impeller bolts, that have had special figures quoted.

Table 19: Metric fasteners

Thread Size	Torque		
	Steel		Stainless steel
	Nuts and bolts	Nuts on studs	All
M6 x 1.0	11.7 Nm (8.6 lb-ft)	4.6 Nm (3.4 lb-ft)	9 Nm (6.6 lb-ft)
M8 x 1.25	28 Nm (21 lb-ft)	11 Nm (8 lb-ft)	22 Nm (16 lb-ft)
M10 x 1.5	56 Nm (41 lb-ft)	22 Nm (16 lb-ft)	44 Nm (32 lb-ft)
M12 x 1.75	98 Nm (72 lb-ft)	38 Nm (28 lb-ft)	76 Nm (56 lb-ft)
M16 x 2.0	244 Nm (180 lb-ft)	95 Nm (70 lb-ft)	187 Nm (138 lb-ft)
M20 x 2.5	476 Nm (351 lb-ft)	185 Nm (136 lb-ft)	364 Nm (268 lb-ft)
M24 x 3.0	822 Nm (606 lb-ft)	320 Nm (236 lb-ft)	629 Nm (464 lb-ft)
M30 x 3.5	1633 Nm (1204 lb-ft)	633 Nm (467 lb-ft)	1240 Nm (915 lb-ft)

These figures are for metric fasteners that meet BS3692:

- Grade 8.8 for steel bolts.
- Grade 4.6 for steel studs.
- Grade 10 for steel nuts.
- Grade A2 for all stainless steel fasteners.

Table 20: UNC fasteners

Thread Size	Torque		
	Steel		Stainless steel
	Nuts and bolts	Nuts on studs	All
1/4" – 20	13.5 Nm (10 lb-ft)	5.4 Nm (4 lb-ft)	10.5 Nm (7.7 lb-ft)
5/16" – 18	27.1 Nm (20 lb-ft)	10.5 Nm (7.7 lb-ft)	21.0 Nm (15.5 lb-ft)
3/8" – 16	48.8 Nm (36 lb-ft)	20 Nm (14.8 lb-ft)	37.8 Nm (27.9 lb-ft)
7/16" – 14	74.6 Nm (55 lb-ft)	30 Nm (22.1 lb-ft)	57.8 Nm (42.6 lb-ft)
1/2" – 13	122 Nm (90 lb-ft)	48 Nm (35.4 lb-ft)	94.6 Nm (69.8 lb-ft)
5/8" – 11	273.3 Nm (201.5 lb-ft)	95 Nm (70.1 lb-ft)	183.9 Nm (135.6 lb-ft)
3/4" – 10	420.4 Nm (310 lb-ft)	167 Nm (123.2 lb-ft)	325.8 Nm (240.3 lb-ft)
7/8" – 9	664.4 Nm (490 lb-ft)	266 Nm (196.2 lb-ft)	514.9 Nm (379.8 lb-ft)
1" – 8	1003 Nm (740 lb-ft)	401 Nm (295.8 lb-ft)	777.3 Nm (573.3 lb-ft)

These figures are for UNC fasteners that meet BS1768:

- Grade S for steel bolts and studs.
- Grade 3 for steel nuts.
- Grade A2 for all stainless steel fasteners.

Table 21: Correction factors

If the fasteners are of a dissimilar condition to the fasteners previously mentioned, then multiply by the appropriate correction factor.

Plating condition of the nut	Plating condition of the bolt	
	Black	Zinc
Black	1.0	0.9
Zinc	0.9	0.8

Impeller capscrew torque values

These values are for stainless steel fasteners that are grade A2 and A4, property class 70 and 80.

Property class	M4	M5	M6	M8	M10	M12	M16	M20	M24	M30
70 and 80	2.7 Nm (2 lb-ft)	5.4 Nm (4 lb-ft)	(6.9 lb-ft) 9.3 Nm	22 Nm (16 lb-ft)	44 Nm (32 lb-ft)	76 Nm (56 lb-ft)	187 Nm (138 lb-ft)	364 Nm (268 lb-ft)	629 Nm (464 lb-ft)	1240 Nm (915 lb-ft)

8.4 Belt tensioning

The pulley center distance (A) controls the tension of the belt.

8.4.1 Force and deflection method

1. Apply the correct force (F) at the middle of the span of the belt. Ensure that the force is applied evenly across the width of the belt and at a right angle to the belt.
2. Measure the deflection (d).
3. Check the measurement against the correct value given:
 - a) For air compressors with an oil feed from the engine, compare the measured value against the value that is given in [Table 22: Force and deflection values for belts on air compressors with an oil feed from the engine](#) on page 64
 - b) For air compressors with an integral oil sump, use 0.38 (10 mm) for A belt deflection and 0.50 in (13 mm) for B belt deflection.
4. To obtain the correct deflection value:
 - a) For air compressors with an oil feed from the engine, add or remove shims beneath the compressor.
 - b) For air compressors with an integral oil sump, loosen the air compressor fasteners and move the air compressor towards or away from the driving pulley. Tighten the fasteners fully when the correct deflection is obtained.

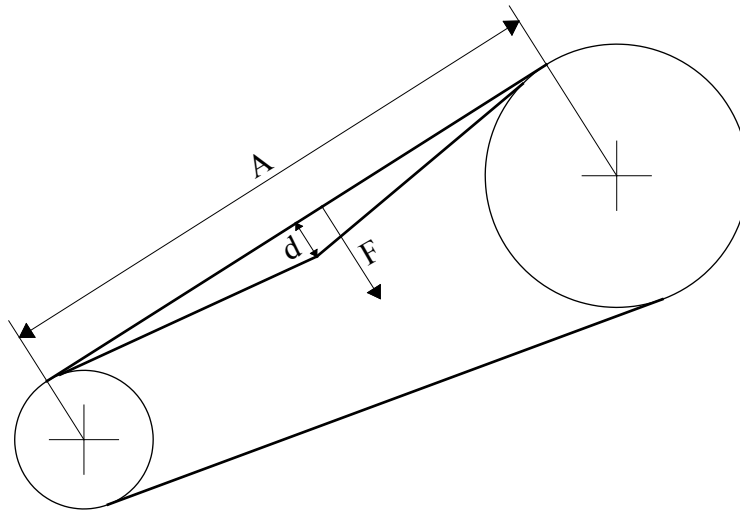

8.4.2 Belt frequency method

This method is only suitable for air compressors that are fed oil from the engine.

1. To measure the frequency of the belt, use a belt frequency meter.
2. Compare the measurement against the given values.

For a new belt, use the value given in the *As built* column. For a belt with more than three hours of service, use the value that is given in the *Run in* column.

The values given are based upon an ambient temperature of 20°C (68°F).
3. To adjust the tension of the belt, add or remove shims from beneath the compressor.

8.4.3 Belt tension values

Table 22: Force and deflection values for belts on air compressors with an oil feed from the engine

Pump	Pulley centers (A)	Belt type	Force (F)	Deflection (d)	Frequency (Hz)	
					As built	Run in
NC80 NC100 NC150	291.8 mm (11.49 in)	Timing	24.5 N (5.51 lb.f)	6 mm (0.24 in)	85	70 – 80

Pump	Pulley centers (A)	Belt type	Force (F)	Deflection (d)	Frequency (Hz)	
					As built	Run in
NC80 NC100 NC150	207.0 mm (8.15 in)	HTD	23.5 N (4.86 lb.f)	6 mm (0.24 in)	95	80 – 90
NC150S	262.0 mm (10.31 in)	HTD	19.9 N (4.47 lb f)	5 mm (0.20 in)	106	90 – 100

8.5 Impeller to wear plate clearances

Table 23: Required clearances between the impeller and the front wear plate

Pump model	Clearance between the impeller and the front wear plate
NC80	0.200 mm to 0.800 mm (0.008 in to 0.032 in)
NC100	
NC150	
NC150S	
NC350	

Xylem |'zīləm|

- 1) The tissue in plants that brings water upward from the roots;
- 2) a leading global water technology company.

We're a global team unified in a common purpose: creating advanced technology solutions to the world's water challenges. Developing new technologies that will improve the way water is used, conserved, and re-used in the future is central to our work. Our products and services move, treat, analyze, monitor and return water to the environment, in public utility, industrial, residential and commercial building services, and agricultural settings. With its October 2016 acquisition of Sensus, Xylem added smart metering, network technologies and advanced data analytics for water, gas and electric utilities to its portfolio of solutions. In more than 150 countries, we have strong, long-standing relationships with customers who know us for our powerful combination of leading product brands and applications expertise with a strong focus on developing comprehensive, sustainable solutions.

For more information on how Xylem can help you, go to www.xylem.com



Xylem Dewatering Solutions UK Ltd
Quenington
Cirencester, Gloucestershire GL7
5BX
UK
Tel: +44 (0)1285 750271
Fax: +44 (0)1285 750352
sales@godwinpumps.co.uk
www.xylem.com

Visit our Web site for the latest version of this document and more information

The original instruction is in English. All non-English instructions are translations of the original instruction.

© 2017 Xylem Inc