



# Flygt 3153, 50Hz



---

# Table of Contents

<b>F-pump, Standard Motor</b> .....	<b>2</b>
Product description.....	2
Motor rating and performance curves.....	5
<b>F-pump, Premium Efficiency Motor (IE3)</b> .....	<b>9</b>
Product description.....	9
Motor rating and performance curves.....	11
<b>N-pump, Standard Motor</b> .....	<b>15</b>
Product description.....	15
Motor rating and performance curves.....	18
<b>N-pump, Premium Efficiency Motor (IE3)</b> .....	<b>23</b>
Product description.....	23
Motor rating and performance curves.....	26
<b>Dimensions and Weight</b> .....	<b>30</b>
Drawings.....	30

# F-pump, Standard Motor

## Product description



### Usage

A submersible chopper pump for liquid manure, fish waste, or heavily contaminated sewage and sludge. The N-hydraulic is fitted with a cutting insert ring. Both impeller and insert ring are manufactured in Hard-Iron™.

### Denomination

Type	Non explosion proof version	Explosion proof version	Pressure class	Installation types
Hard-Iron™ Chopper	3153.350	3153.390	MT – Medium head HT – High head SH – Super head	P, S, T, Z

The pump can be used in the following installations:

- P Semi permanent, wet well arrangement with pump installed on two guide bars with automatic connection to discharge.
- S Portable semi permanent, wet well arrangement with hose coupling or flange for connection to discharge pipeline.
- T Vertical permanent, dry well arrangement with flange connection to suction and discharge piping.
- Z Horizontal permanent, dry well arrangement with flange connection to suction and discharge piping.

### Application limits

Feature	Description
Liquid temperature	Maximum 40°C (104°F)
Liquid temperature, warm water version	Maximum 70°C (158°F)
Depth of immersion	Maximum 20 m (65 ft)
pH of the pumped liquid	5.5 - 14
Liquid density	Maximum 1100 kg/m <sup>3</sup>

## Motor data

Feature	Description
Motor type	Squirrel-cage induction motor
Frequency	50 Hz
Power supply	3-phase
Starting method	<ul style="list-style-type: none"> <li>• Direct on-line</li> <li>• Star-delta</li> <li>• Variable Frequency Drive (VFD)</li> </ul>
Number of starts per hour	Maximum 30
Code compliance	IEC 60034-1
Rated output variation	±10%
Voltage variation	<ul style="list-style-type: none"> <li>• Continuously running: Maximum ±5%</li> <li>• Intermittent running: Maximum ±10%</li> </ul>
Voltage imbalance between phases	Maximum 2%
Stator insulation class	H (180°C, 356°F)

## Cables

Application	Type
Direct-on-line start or Y/D start with two cables	Flygt SUBCAB® - a heavy duty 4 cores motor power cable with two twisted pair screened control cores. Conductor insulation rating of 90°C, which allows for increased current. Superior mechanical strength and high abrasion and tear resistant. Chemical resistant within pH 3-10 and ozone, oil, and flame resistant. Used up to 70°C water temperature. Cables < 10 mm <sup>2</sup> with unscreened control cores.
Y/D start	Flygt SUBCAB® - a heavy duty 7 cores motor power cable with two twisted pair screened control cores. Conductor insulation rating of 90°C, which allows for increased current. Superior mechanical strength and high abrasion and tear resistant. Chemical resistant within pH 3-10 and ozone, oil, and flame resistant. Used up to 70°C water temperature. Cables < 7G6 mm <sup>2</sup> with unscreened control cores.
Variable Frequency drive	Screened Flygt SUBCAB® - a heavy duty 4 screened cores motor power cable with four twisted pair screened control cores. Conductor insulation rating of 90°C, which allows for increased current. Superior mechanical strength and high abrasion and tear resistant. Chemical resistant within pH 3-10 and ozone, oil, and flame resistant. Used up to 70°C water temperature.

## Monitoring equipment

- Thermal contacts opening temperature 140° C (284° F)
- Leakage sensor in the inspection chamber (FLS 10)

## Materials

Table 1: Major parts except mechanical seals

Denomination	Material	ASTM	EN
Major castings	Cast iron, gray	35B	GJL-250
Pump housing	Cast iron, gray	35B	GJL-250
Impeller	Cast iron, Hard-Iron™	A 532 IIIA	GJN-HB555(XCR23)

Denomination	Material	ASTM	EN
Insert ring	Cast iron, Hard-Iron™	A 532 IIIA	GJN-HB555(XCR23)
Cooling jacket, inner	Aluminum	AA 1050A	AW-1050A
Cooling jacket, outer, alternative 1	Steel	GR65	S235JRG2
Cooling jacket, outer, alternative 2	Stainless steel	AISI 316L	1.4404,1.4432, ...
Lifting handle	Stainless steel	AISI 316L	1.4404,1.4432, ...
Shaft	Stainless steel	AISI 431	1.4057+QT800
Screws and nuts	Stainless steel, A4	AISI 316L, 316, 316Ti	1.4401,1.4404, ...
O-rings, alternative 1	Nitrile rubber (NBR) 70° IRH	-	-
O-rings, alternative 2	Fluorinated rubber (FPM) 70° IRH	-	-
Glycol, part no 903708	Heat transfer fluid based on monopropylene glycol. Fulfills FDA 184.1666/182.6285.	-	-

Table 2: Mechanical seals

Alternative	Inner seal	Outer seal
1	Corrosion resistant cemented carbide/ Corrosion resistant cemented carbide	Corrosion resistant cemented carbide/ Corrosion resistant cemented carbide
2	Corrosion resistant cemented carbide/ Corrosion resistant cemented carbide	Silicon carbide/ Silicon carbide

Surface treatment

Priming	Finish
Painted with a primer, see internal standard M0700.00.0002	Navy gray color NCS 5804-B07G. Two-component high-solid top coating, see internal standard M0700.00.0004 for standard painting and M0700.00.0008 for special painting.

Options

- Warm liquid version (non-explosion proof versions)
- Sensors: Thermistor, FLS, Pt 100, VIS 10
- Feed control (chopper)
  - pressure class MT
- Aqua cutting knife (chopper)
  - pressure class MT, HT
- Surface treatment (Epoxy)
- Zinc anodes
- Other cables

Accessories

Discharge connections, adapters, hose connections, and other mechanical accessories. Electrical accessories such as pump controller, control panels, starters, monitoring relays, cables.

## Motor rating and performance curves

These are examples of motor rating and curves. For more information, please contact your local sales and service representative.

Star-delta starting current is 1/3 of Direct on-line starting current.

MT

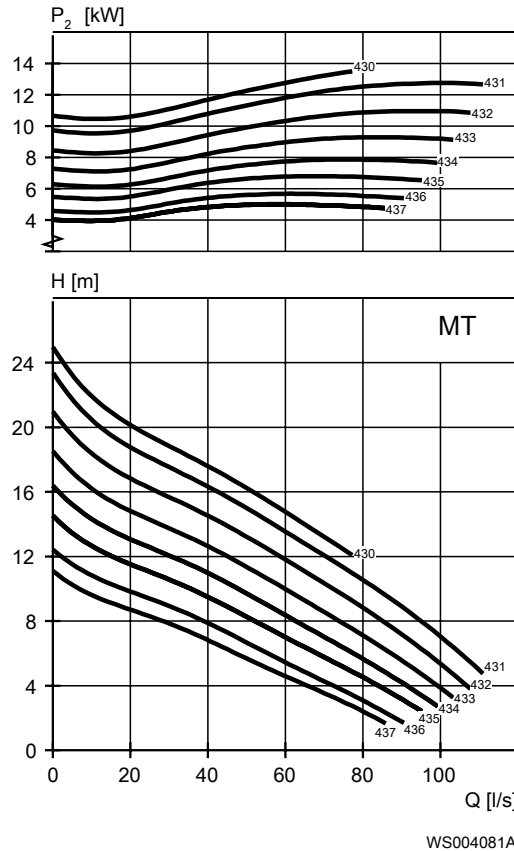

Figure 1: Manure

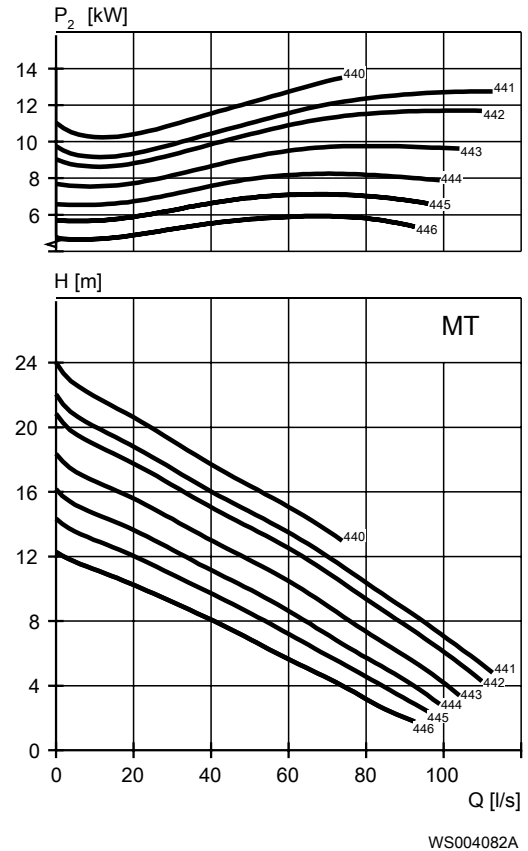

Figure 2: Long fibrous manure

Table 3: 400 V, 50 Hz, 3-phase

Rated power, kW	Rated power, hp	Curve/ Impeller No	Revolutions per minute, rpm	Rated current, A	Starting current, A	Power factor, $\cos \phi$	Installation
7.5	10.1	435	1465	16	107	0.76	P,S,T,Z
7.5	10.1	436	1465	16	107	0.76	P,S,T,Z
7.5	10.1	437	1465	16	107	0.76	P,S,T,Z
7.5	10.1	445	1465	16	107	0.76	P,S,T,Z
7.5	10.1	446	1465	16	107	0.76	P,S,T,Z
9	12.1	434	1460	19	107	0.8	P,S,T,Z
9	12.1	435	1460	19	107	0.8	P,S,T,Z
9	12.1	436	1460	19	107	0.8	P,S,T,Z
9	12.1	437	1460	19	107	0.8	P,S,T,Z
9	12.1	444	1460	19	107	0.8	P,S,T,Z
9	12.1	445	1460	19	107	0.8	P,S,T,Z
9	12.1	446	1460	19	107	0.8	P,S,T,Z
13.5	18.1	430	1455	27	145	0.82	P,S,T,Z

Rated power, kW	Rated power, hp	Curve/ Impeller No	Revolutions per minute, rpm	Rated current, A	Starting current, A	Power factor, cos φ	Installation
13.5	18.1	431	1455	27	145	0.82	P,S,T,Z
13.5	18.1	432	1455	27	145	0.82	P,S,T,Z
13.5	18.1	433	1455	27	145	0.82	P,S,T,Z
13.5	18.1	434	1455	27	145	0.82	P,S,T,Z
13.5	18.1	435	1455	27	145	0.82	P,S,T,Z
13.5	18.1	436	1455	27	145	0.82	P,S,T,Z
13.5	18.1	437	1455	27	145	0.82	P,S,T,Z
13.5	18.1	440	1455	27	145	0.82	P,S,T,Z
13.5	18.1	441	1455	27	145	0.82	P,S,T,Z
13.5	18.1	442	1455	27	145	0.82	P,S,T,Z
13.5	18.1	443	1455	27	145	0.82	P,S,T,Z
13.5	18.1	444	1455	27	145	0.82	P,S,T,Z
13.5	18.1	445	1455	27	145	0.82	P,S,T,Z
13.5	18.1	446	1455	27	145	0.82	P,S,T,Z

HT

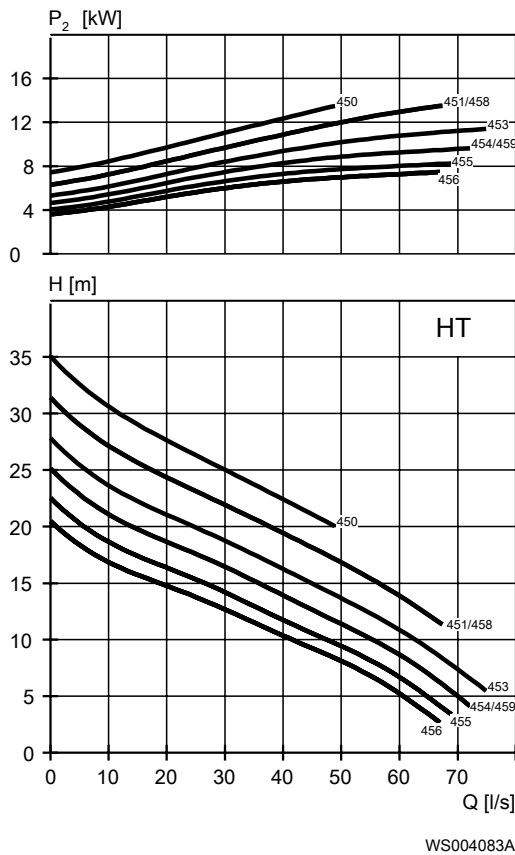
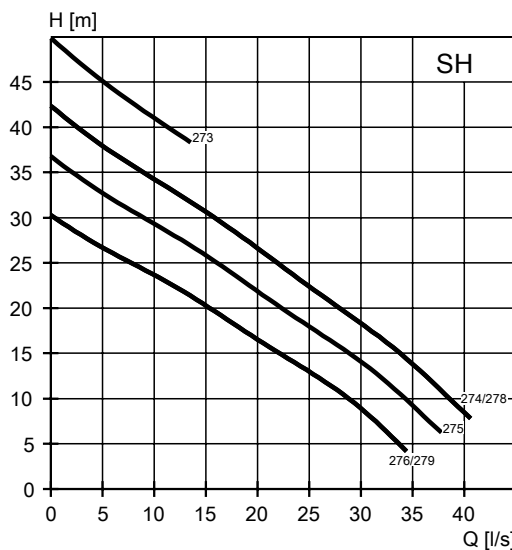
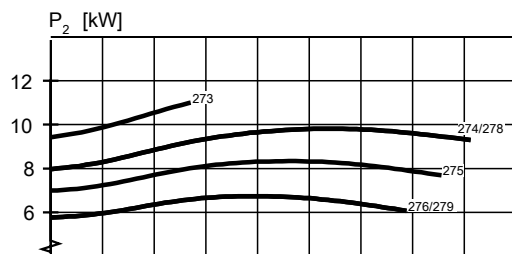

Table 4: 400 V, 50 Hz, 3-phase

Rated power, kW	Rated power, hp	Curve/ Impeller No	Revolutions per minute, rpm	Rated current, A	Starting current, A	Power factor, cos φ	Installation
7.5	10.1	456	1465	16	107	0.76	P,S,T,Z
9	12.1	454	1460	19	107	0.8	P,S,T,Z

Rated power, kW	Rated power, hp	Curve/ Impeller No	Revolutions per minute, rpm	Rated current, A	Starting current, A	Power factor, cos φ	Installation
9	12.1	455	1460	19	107	0.8	P,S,T,Z
9	12.1	456	1460	19	107	0.8	P,S,T,Z
9	12.1	459	1460	19	107	0.8	P,S,T,Z
13.5	18.1	450	1455	27	145	0.82	P,S,T,Z
13.5	18.1	451	1455	27	145	0.82	P,S,T,Z
13.5	18.1	453	1455	27	145	0.82	P,S,T,Z
13.5	18.1	454	1455	27	145	0.82	P,S,T,Z
13.5	18.1	455	1455	27	145	0.82	P,S,T,Z
13.5	18.1	456	1455	27	145	0.82	P,S,T,Z
13.5	18.1	458	1455	27	145	0.82	P,S,T,Z
13.5	18.1	459	1455	27	145	0.82	P,S,T,Z

SH



WS004084A

Figure 3: Rated power 11 kW (14.8 hp)

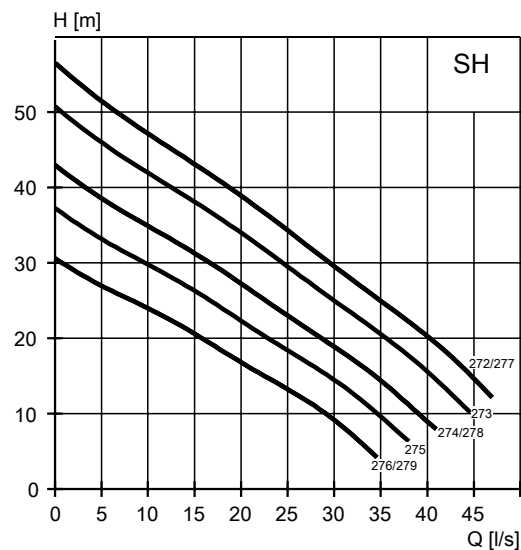
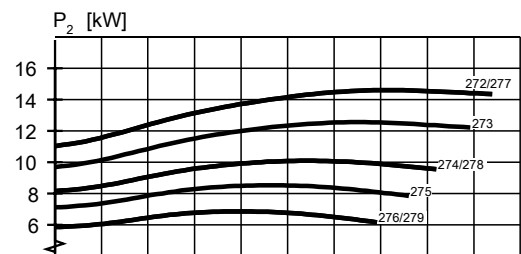

WS004085A

Figure 4: Rated power 15 kW (20 hp)

Table 5: 400 V, 50 Hz, 3-phase

Rated power, kW	Rated power, hp	Curve/ Impeller No	Revolutions per minute, rpm	Rated current, A	Starting current, A	Power factor, cos φ	Installation
11	14.8	273	2905	19	139	0.94	P,S,T,Z
11	14.8	274	2905	19	139	0.94	P,S,T,Z
11	14.8	275	2905	19	139	0.94	P,S,T,Z

Rated power, kW	Rated power, hp	Curve/ Impeller No	Revolutions per minute, rpm	Rated current, A	Starting current, A	Power factor, cos $\phi$	Installation
11	14.8	276	2905	19	139	0.94	P,S,T,Z
11	14.8	278	2905	19	139	0.94	P,S,T,Z
11	14.8	279	2905	19	139	0.94	P,S,T,Z
15	20	272	2910	27	213	0.89	P,S,T,Z
15	20	273	2910	27	213	0.89	P,S,T,Z
15	20	274	2910	27	213	0.89	P,S,T,Z
15	20	275	2910	27	213	0.89	P,S,T,Z
15	20	276	2910	27	213	0.89	P,S,T,Z
15	20	277	2910	27	213	0.89	P,S,T,Z
15	20	278	2910	27	213	0.89	P,S,T,Z
15	20	279	2910	27	213	0.89	P,S,T,Z

# F-pump, Premium Efficiency Motor (IE3)

## Product description



## Usage

A submersible chopper pump for liquid manure, fish waste, or heavily contaminated sewage and sludge. The N-hydraulic is fitted with a cutting insert ring. Both impeller and insert ring are manufactured in Hard-Iron™.

## Denomination

Type	Non explosion proof version	Explosion proof version	Pressure class	Installation types
Hard-Iron™ Chopper	3153.840	3153.850	MT – Medium head HT – High head SH – Super head	P, S, T, Z

The pump can be used in the following installations:

- P Semi permanent, wet well arrangement with pump installed on two guide bars with automatic connection to discharge.
- S Portable semi permanent, wet well arrangement with hose coupling or flange for connection to discharge pipeline.
- T Vertical permanent, dry well arrangement with flange connection to suction and discharge piping.
- Z Horizontal permanent, dry well arrangement with flange connection to suction and discharge piping.

## Application limits

Feature	Description
Liquid temperature	Maximum 40°C (104°F)
Depth of immersion	Maximum 20 m (65 ft)
pH of the pumped liquid	5.5 - 14
Liquid density	Maximum 1100 kg/m <sup>3</sup>

Motor data

Feature	Description
Motor type	Line started permanent magnet motor (LSPM)
Frequency	50 Hz
Power supply	3-phase
Starting method	<ul style="list-style-type: none"> <li>• Direct on-line</li> <li>• Star-delta</li> <li>• Variable Frequency Drive (VFD)</li> </ul>
Number of starts per hour	Maximum 30
Code compliance	IEC 60034-1
Rated output variation	±10%
Voltage variation	<ul style="list-style-type: none"> <li>• Continuously running: Maximum ±5%</li> <li>• Intermittent running: Maximum ±10%</li> </ul>
Voltage imbalance between phases	Maximum 2%
Stator insulation class	H (180°C, 356°F)

Cables

Application	Type
Direct-on-line start or Y/D start with two cables	Flygt SUBCAB® - a heavy duty 4 cores motor power cable with two twisted pair screened control cores. Conductor insulation rating of 90°C, which allows for increased current. Superior mechanical strength and high abrasion and tear resistant. Chemical resistant within pH 3-10 and ozone, oil, and flame resistant. Used up to 70°C water temperature. Cables < 10 mm <sup>2</sup> with unscreened control cores.
Y/D start	Flygt SUBCAB® - a heavy duty 7 cores motor power cable with two twisted pair screened control cores. Conductor insulation rating of 90°C, which allows for increased current. Superior mechanical strength and high abrasion and tear resistant. Chemical resistant within pH 3-10 and ozone, oil, and flame resistant. Used up to 70°C water temperature. Cables < 7G6 mm <sup>2</sup> with unscreened control cores.
Variable Frequency drive	Screened Flygt SUBCAB® - a heavy duty 4 screened cores motor power cable with four twisted pair screened control cores. Conductor insulation rating of 90°C, which allows for increased current. Superior mechanical strength and high abrasion and tear resistant. Chemical resistant within pH 3-10 and ozone, oil, and flame resistant. Used up to 70°C water temperature.

Monitoring equipment

- Thermal contacts opening temperature 140° C (284° F)
- Leakage sensor in the inspection chamber (FLS 10)

Materials

Table 6: Major parts except mechanical seals

Denomination	Material	ASTM	EN
Major castings	Cast iron, gray	35B	GJL-250
Pump housing	Cast iron, gray	35B	GJL-250
Impeller	Cast iron, Hard-Iron™	A 532 IIIA	GJN-HB555(XCR23)

Denomination	Material	ASTM	EN
Insert ring	Cast iron, Hard-Iron™	A 532 IIIA	GJN-HB555(XCR23)
Cooling jacket, inner	Aluminum	AA 1050A	AW-1050A
Cooling jacket, outer, alternative 1	Steel	GR65	S235JRG2
Cooling jacket, outer, alternative 2	Stainless steel	AISI 316L	1.4404,1.4432, ...
Lifting handle	Stainless steel	AISI 316L	1.4404,1.4432, ...
Shaft	Stainless steel	AISI 431	1.4057+QT800
Screws and nuts	Stainless steel, A4	AISI 316L, 316, 316Ti	1.4401,1.4404, ...
O-rings, alternative 1	Nitrile rubber (NBR) 70° IRH	-	-
O-rings, alternative 2	Fluorinated rubber (FPM) 70° IRH	-	-
Glycol, part no 903708	Heat transfer fluid based on monopropylene glycol. Fulfills FDA 184.1666/182.6285.	-	-

Table 7: Mechanical seals

Alternative	Inner seal	Outer seal
1	Corrosion resistant cemented carbide/ Corrosion resistant cemented carbide	Corrosion resistant cemented carbide/ Corrosion resistant cemented carbide
2	Corrosion resistant cemented carbide/ Corrosion resistant cemented carbide	Silicon carbide/ Silicon carbide

### Surface treatment

Priming	Finish
Painted with a primer, see internal standard M0700.00.0002	Navy gray color NCS 5804-B07G. Two-component high-solid top coating, see internal standard M0700.00.0004 for standard painting and M0700.00.0008 for special painting.

### Options

- Sensors: Thermistor, FLS, Pt 100, VIS 10
- Feed control (chopper)
  - pressure class MT
- Aqua cutting knife (chopper)
  - pressure class MT, HT
- Surface treatment (Epoxy)
- Zinc anodes
- Other cables

### Accessories

Discharge connections, adapters, hose connections, and other mechanical accessories.  
Electrical accessories such as pump controller, control panels, starters, monitoring relays, cables.

## Motor rating and performance curves

These are examples of motor rating and curves. For more information, please contact your local sales and service representative.

Star-delta starting current is 1/3 of Direct on-line starting current.

MT

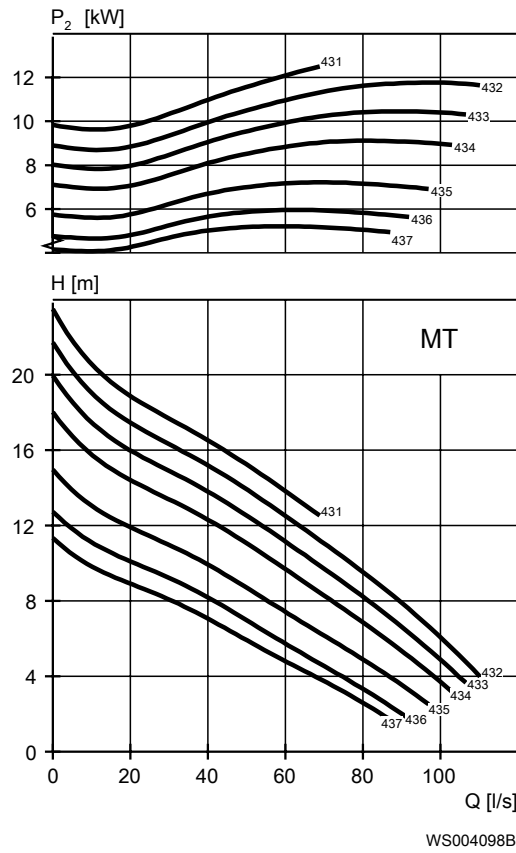

Figure 5: Manure

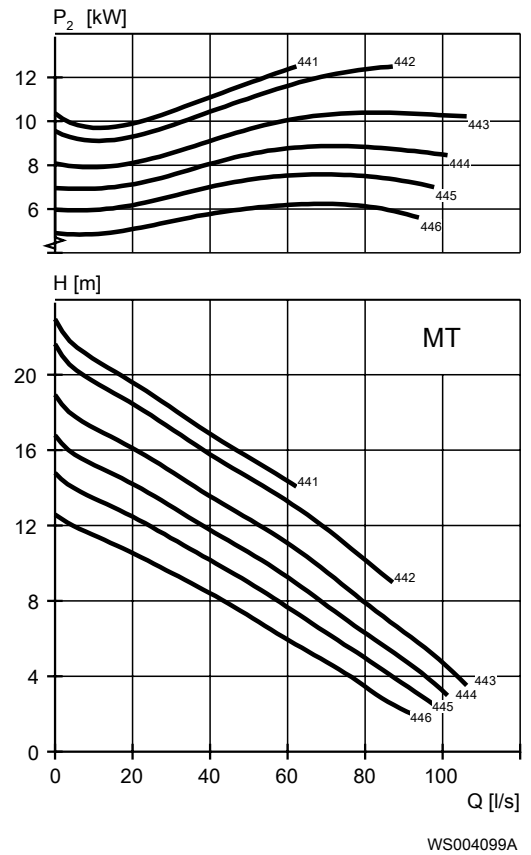

Figure 6: Long fibrous manure

Table 8: 400 V, 50 Hz, 3-phase

Rated power, kW	Rated power, hp	Curve/ Impeller No	Revolutions per minute, rpm	Rated current, A	Starting current, A	Power factor, cos $\phi$	Installation
12.5	16.8	431	1500	21	145	0.95	P,S,T,Z
12.5	16.8	432	1500	21	145	0.95	P,S,T,Z
12.5	16.8	433	1500	21	145	0.95	P,S,T,Z
12.5	16.8	434	1500	21	145	0.95	P,S,T,Z
12.5	16.8	435	1500	21	145	0.95	P,S,T,Z
12.5	16.8	436	1500	21	145	0.95	P,S,T,Z
12.5	16.8	437	1500	21	145	0.95	P,S,T,Z
12.5	16.8	441	1500	21	145	0.95	P,S,T,Z
12.5	16.8	442	1500	21	145	0.95	P,S,T,Z
12.5	16.8	443	1500	21	145	0.95	P,S,T,Z
12.5	16.8	444	1500	21	145	0.95	P,S,T,Z
12.5	16.8	445	1500	21	145	0.95	P,S,T,Z
12.5	16.8	446	1500	21	145	0.95	P,S,T,Z

HT

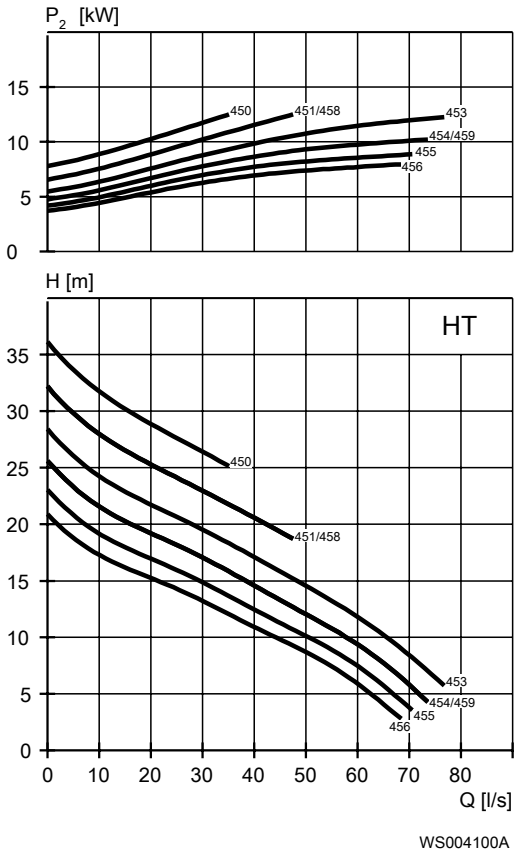
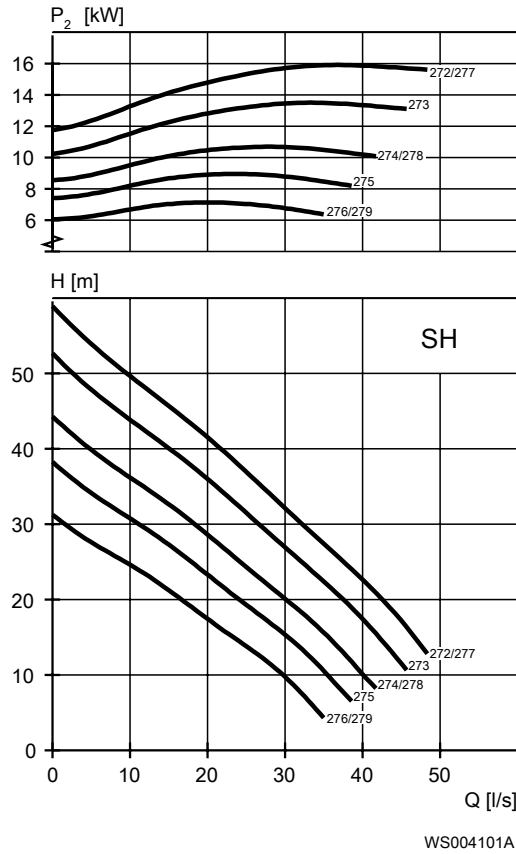

Table 9: 400 V, 50 Hz, 3-phase

Rated power, kW	Rated power, hp	Curve/ Impeller No	Revolutions per minute, rpm	Rated current, A	Starting current, A	Power factor, cos φ	Installation
12.5	16.8	450	1500	21	145	0.95	P,S,T,Z
12.5	16.8	451	1500	21	145	0.95	P,S,T,Z
12.5	16.8	453	1500	21	145	0.95	P,S,T,Z
12.5	16.8	454	1500	21	145	0.95	P,S,T,Z
12.5	16.8	455	1500	21	145	0.95	P,S,T,Z
12.5	16.8	456	1500	21	145	0.95	P,S,T,Z
12.5	16.8	458	1500	21	145	0.95	P,S,T,Z
12.5	16.8	459	1500	21	145	0.95	P,S,T,Z

SH



WS004101A

Table 10: 400 V, 50 Hz, 3-phase

IE3 compliance is based on Y-connected stator.

Rated power, kW	Rated power, hp	Curve/ Impeller No	Revolutions per minute, rpm	Rated current, A	Starting current, A	Power factor, cos $\varphi$	Installation
16.4	22	272	3000	30	213	0.85	P,S,T,Z
16.4	22	273	3000	30	213	0.85	P,S,T,Z
16.4	22	274	3000	30	213	0.85	P,S,T,Z
16.4	22	275	3000	30	213	0.85	P,S,T,Z
16.4	22	276	3000	30	213	0.85	P,S,T,Z
16.4	22	277	3000	30	213	0.85	P,S,T,Z
16.4	22	278	3000	30	213	0.85	P,S,T,Z
16.4	22	279	3000	30	213	0.85	P,S,T,Z

# N-pump, Standard Motor

## Product description



## Usage

A submersible pump for efficient pumping of clean water, surface water, and wastewater containing solids or long-fibered material. The pump is designed for sustained high efficiency. For abrasive media, Hard-Iron™ is required.

## Denomination

Type	Non explosion proof version	Explosion proof version	Pressure class	Installation types
Cast iron	3153.181	3153.091	LT – Low head MT – Medium head HT – High head SH – Super head	P, S, T, Z
Hard-Iron™	3153.185	3153.095	LT – Low head MT – Medium head HT – High head SH – Super head	P, S, T, Z

The pump can be used in the following installations:

- P Semi permanent, wet well arrangement with pump installed on two guide bars with automatic connection to discharge.
- S Portable semi permanent, wet well arrangement with hose coupling or flange for connection to discharge pipeline.
- T Vertical permanent, dry well arrangement with flange connection to suction and discharge piping.
- Z Horizontal permanent, dry well arrangement with flange connection to suction and discharge piping.

## Application limits

Feature	Description
Liquid temperature	Maximum 40°C (104°F)
Liquid temperature, warm water version	Maximum 70°C (158°F)

Feature	Description
Depth of immersion	Maximum 20 m (65 ft)
pH of the pumped liquid	5.5 - 14
Liquid density	Maximum 1100 kg/m <sup>3</sup>

Motor data

Feature	Description
Motor type	Squirrel-cage induction motor
Frequency	50 Hz
Power supply	3-phase
Starting method	<ul style="list-style-type: none"> <li>• Direct on-line</li> <li>• Star-delta</li> <li>• Variable Frequency Drive (VFD)</li> </ul>
Number of starts per hour	Maximum 30
Code compliance	IEC 60034-1
Rated output variation	±10%
Voltage variation	<ul style="list-style-type: none"> <li>• Continuously running: Maximum ±5%</li> <li>• Intermittent running: Maximum ±10%</li> </ul>
Voltage imbalance between phases	Maximum 2%
Stator insulation class	H (180°C, 356°F)

Cables

Application	Type
Direct-on-line start or Y/D start with two cables	Flygt SUBCAB® - a heavy duty 4 cores motor power cable with two twisted pair screened control cores. Conductor insulation rating of 90°C, which allows for increased current. Superior mechanical strength and high abrasion and tear resistant. Chemical resistant within pH 3-10 and ozone, oil, and flame resistant. Used up to 70°C water temperature. Cables < 10 mm <sup>2</sup> with unscreened control cores.
Y/D start	Flygt SUBCAB® - a heavy duty 7 cores motor power cable with two twisted pair screened control cores. Conductor insulation rating of 90°C, which allows for increased current. Superior mechanical strength and high abrasion and tear resistant. Chemical resistant within pH 3-10 and ozone, oil, and flame resistant. Used up to 70°C water temperature. Cables < 7G6 mm <sup>2</sup> with unscreened control cores.
Variable Frequency drive	Screened Flygt SUBCAB® - a heavy duty 4 screened cores motor power cable with four twisted pair screened control cores. Conductor insulation rating of 90°C, which allows for increased current. Superior mechanical strength and high abrasion and tear resistant. Chemical resistant within pH 3-10 and ozone, oil, and flame resistant. Used up to 70°C water temperature.

Monitoring equipment

- Thermal contacts opening temperature 140° C (284° F)
- Leakage sensor in the inspection chamber (FLS 10)

## Materials

Table 11: Major parts except mechanical seals

Denomination	Material	ASTM	EN
Major castings	Cast iron, gray	35B	GJL-250
Pump housing	Cast iron, gray	35B	GJL-250
Impeller, alternative 1	Cast iron, gray	35B	GJL-250
Impeller, alternative 2	Cast iron, Hard-Iron™	A 532 IIIA	GJN-HB555(XCR23)
Insert ring, alternative 1	Cast iron, gray	35B	GJL-250
Insert ring, alternative 2	Cast iron, Hard-Iron™	A 532 IIIA	GJN-HB555(XCR23)
Cooling jacket, inner	Aluminum	AA 1050A	AW-1050A
Cooling jacket, outer, alternative 1	Steel	GR65	S235JRG2
Cooling jacket, outer, alternative 2	Stainless steel	AISI 316L	1.4404, 1.4432, ...
Lifting handle	Stainless steel	AISI 316L	1.4404, 1.4432, ...
Shaft	Stainless steel	AISI 431	1.4057+QT800
Screws and nuts	Stainless steel, A4	AISI 316L, 316, 316Ti	1.4401, 1.4404, ...
O-rings, alternative 1	Nitrile rubber (NBR) 70° IRH	-	-
O-rings, alternative 2	Fluorinated rubber (FPM) 70° IRH	-	-
Glycol, part no 903708	Heat transfer fluid based on monopropylene glycol. Fulfills FDA 184.1666/182.6285.	-	-

Table 12: Mechanical seals

Alternative	Inner seal	Outer seal
1	Corrosion resistant cemented carbide/ Corrosion resistant cemented carbide	Corrosion resistant cemented carbide/ Corrosion resistant cemented carbide
2	Corrosion resistant cemented carbide/ Corrosion resistant cemented carbide	Silicon carbide/ Silicon carbide

## Surface treatment

Priming	Finish
Painted with a primer, see internal standard M0700.00.0002	Navy gray color NCS 5804-B07G. Two-component high-solid top coating, see internal standard M0700.00.0004 for standard painting and M0700.00.0008 for special painting.

## Options

- Warm liquid version (non-explosion proof versions)
- Sensors: Thermistor, FLS, Pt 100, VIS 10
- Surface treatment (Epoxy)
- Zinc anodes
- Other cables

## Accessories

Discharge connections, adapters, hose connections, and other mechanical accessories.

Electrical accessories such as pump controller, control panels, starters, monitoring relays, cables.

## Motor rating and performance curves

These are examples of motor rating and curves. For more information, please contact your local sales and service representative.

Star-delta starting current is 1/3 of Direct on-line starting current.

LT

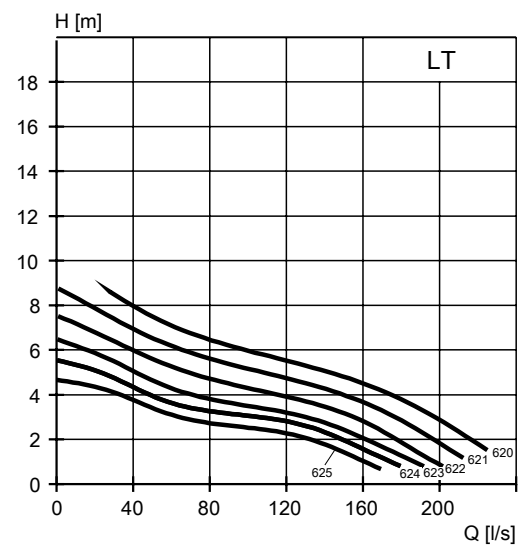
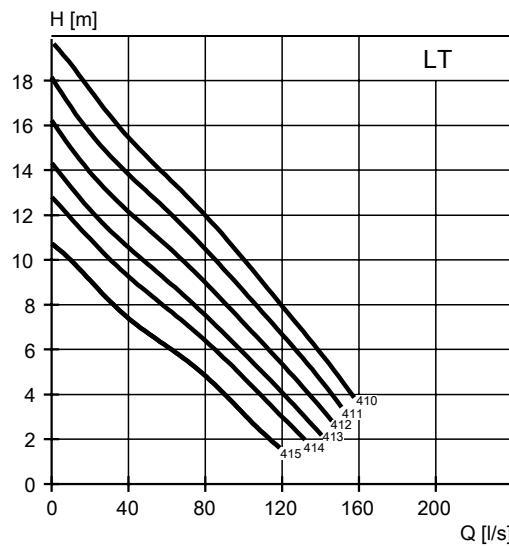
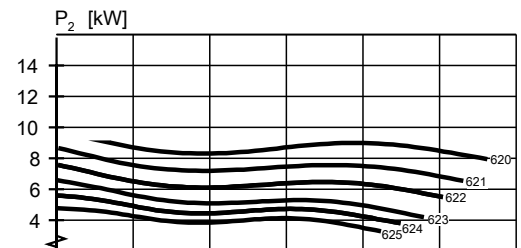
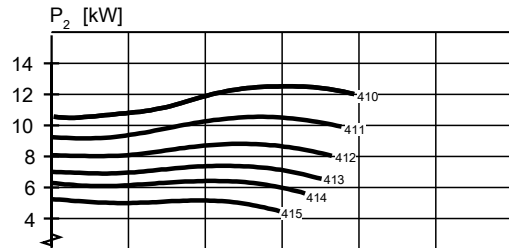

WS004070A

WS004071A

Table 13: 400 V, 50 Hz, 3-phase

Rated power, kW	Rated power, hp	Curve/ Impeller No	Revolutions per minute, rpm	Rated current, A	Starting current, A	Power factor, cos φ	Installation
7.5	10.1	413	1465	16	107	0.76	P,S,T,Z
7.5	10.1	414	1465	16	107	0.76	P,S,T,Z
7.5	10.1	415	1465	16	107	0.76	P,S,T,Z
9	12.1	412	1460	19	107	0.8	P,S,T,Z
9	12.1	413	1460	19	107	0.8	P,S,T,Z
9	12.1	414	1460	19	107	0.8	P,S,T,Z
9	12.1	415	1460	19	107	0.8	P,S,T,Z
9	12.1	620	955	21	90	0.72	P,S,T,Z
9	12.1	620	955	21	90	0.72	P,S,T,Z
9	12.1	622	955	21	90	0.72	P,S,T,Z
9	12.1	623	955	21	90	0.72	P,S,T,Z

Rated power, kW	Rated power, hp	Curve/ Impeller No	Revolutions per minute, rpm	Rated current, A	Starting current, A	Power factor, cos $\phi$	Installation
9	12.1	624	955	21	90	0.72	P,S,T,Z
9	12.1	625	955	21	90	0.72	P,S,T,Z
13.5	18.1	410	1455	27	145	0.82	P,S,T,Z
13.5	18.1	411	1455	27	145	0.82	P,S,T,Z
13.5	18.1	412	1455	27	145	0.82	P,S,T,Z
13.5	18.1	413	1455	27	145	0.82	P,S,T,Z
13.5	18.1	414	1455	27	145	0.82	P,S,T,Z
13.5	18.1	415	1455	27	145	0.82	P,S,T,Z

MT

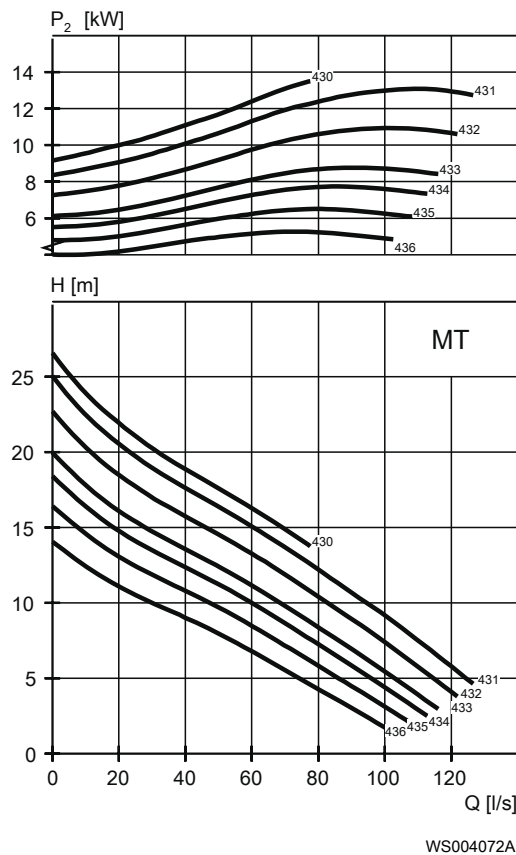

WS004072A

Table 14: 400 V, 50 Hz, 3-phase

Rated power, kW	Rated power, hp	Curve/ Impeller No	Revolutions per minute, rpm	Rated current, A	Starting current, A	Power factor, cos $\phi$	Installation
7.5	10.1	434	1465	16	107	0.76	P,S,T,Z
7.5	10.1	435	1465	16	107	0.76	P,S,T,Z
7.5	10.1	436	1465	16	107	0.76	P,S,T,Z
9	12.1	433	1460	19	107	0.8	P,S,T,Z
9	12.1	434	1460	19	107	0.8	P,S,T,Z
9	12.1	435	1460	19	107	0.8	P,S,T,Z
9	12.1	436	1460	19	107	0.8	P,S,T,Z
13.5	18.1	430	1455	27	145	0.82	P,S,T,Z

Rated power, kW	Rated power, hp	Curve/ Impeller No	Revolutions per minute, rpm	Rated current, A	Starting current, A	Power factor, cos φ	Installation
13.5	18.1	431	1455	27	145	0.82	P,S,T,Z
13.5	18.1	432	1455	27	145	0.82	P,S,T,Z
13.5	18.1	433	1455	27	145	0.82	P,S,T,Z
13.5	18.1	434	1455	27	145	0.82	P,S,T,Z
13.5	18.1	435	1455	27	145	0.82	P,S,T,Z
13.5	18.1	436	1455	27	145	0.82	P,S,T,Z

HT

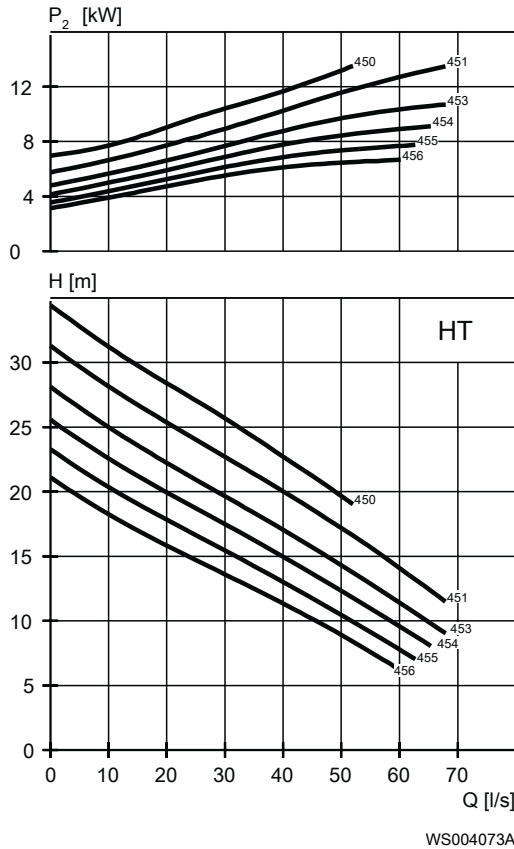
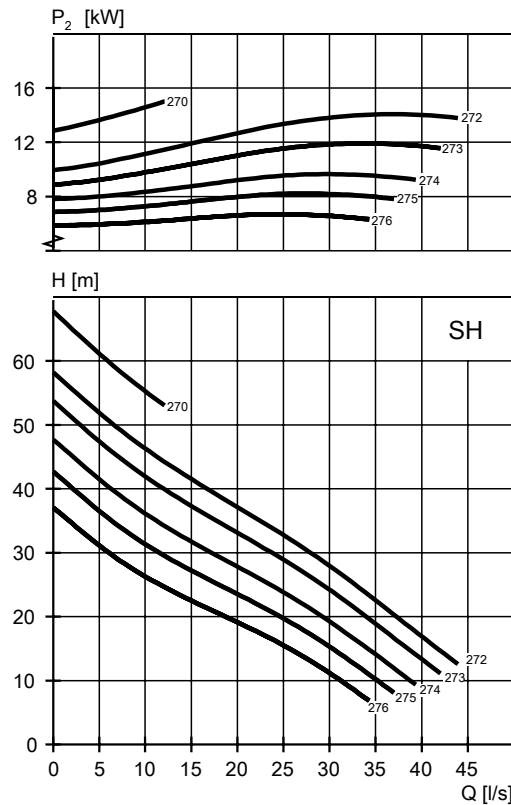

Table 15: 400 V, 50 Hz, 3-phase

Rated power, kW	Rated power, hp	Curve/ Impeller No	Revolutions per minute, rpm	Rated current, A	Starting current, A	Power factor, cos φ	Installation
7.5	10.1	451	1465	16	107	0.76	P,S,T,Z
7.5	10.1	453	1465	16	107	0.76	P,S,T,Z
7.5	10.1	454	1465	16	107	0.76	P,S,T,Z
7.5	10.1	455	1465	16	107	0.76	P,S,T,Z
7.5	10.1	456	1465	16	107	0.76	P,S,T,Z
9	12.1	450	1460	19	107	0.8	P,S,T,Z
9	12.1	451	1460	19	107	0.8	P,S,T,Z
9	12.1	453	1460	19	107	0.8	P,S,T,Z
9	12.1	454	1460	19	107	0.8	P,S,T,Z
9	12.1	455	1460	19	107	0.8	P,S,T,Z

Rated power, kW	Rated power, hp	Curve/ Impeller No	Revolutions per minute, rpm	Rated current, A	Starting current, A	Power factor, cos $\phi$	Installation
9	12.1	456	1460	19	107	0.8	P,S,T,Z
13.5	18.1	450	1455	27	145	0.82	P,S,T,Z
13.5	18.1	451	1455	27	145	0.82	P,S,T,Z
13.5	18.1	453	1455	27	145	0.82	P,S,T,Z
13.5	18.1	454	1455	27	145	0.82	P,S,T,Z
13.5	18.1	455	1455	27	145	0.82	P,S,T,Z
13.5	18.1	456	1455	27	145	0.82	P,S,T,Z

SH



WS004074A

Table 16: 400 V, 50 Hz, 3-phase

Rated power, kW	Rated power, hp	Curve/ Impeller No	Revolutions per minute, rpm	Rated current, A	Starting current, A	Power factor, cos $\phi$	Installation
11	14.8	273	2905	19	139	0.94	P,S,T,Z
11	14.8	274	2905	19	139	0.94	P,S,T,Z
11	14.8	275	2905	19	139	0.94	P,S,T,Z
11	14.8	276	2905	19	139	0.94	P,S,T,Z
15	20	270	2910	27	213	0.89	P,S,T,Z
15	20	272	2910	27	213	0.89	P,S,T,Z
15	20	273	2910	27	213	0.89	P,S,T,Z
15	20	274	2910	27	213	0.89	P,S,T,Z
15	20	275	2910	27	213	0.89	P,S,T,Z

---

Rated power, kW	Rated power, hp	Curve/ Impeller No	Revolutions per minute, rpm	Rated current, A	Starting current, A	Power factor, $\cos \phi$	Installation
15	20	276	2910	27	213	0.89	P,S,T,Z

# N-pump, Premium Efficiency Motor (IE3)

## Product description



## Usage

A submersible pump for efficient pumping of clean water, surface water, and wastewater containing solids or long-fibered material. The pump is designed for sustained high efficiency. For abrasive media, Hard-Iron™ is required.

## Denomination

Type	Non explosion proof version	Explosion proof version	Pressure class	Installation types
Cast iron	3153.800	3153.810	LT – Low head MT – Medium head HT – High head SH – Super head	P, S, T, Z
Hard-Iron™	3153.820	3153.830	LT – Low head MT – Medium head HT – High head SH – Super head	P, S, T, Z

The pump can be used in the following installations:

- P Semi permanent, wet well arrangement with pump installed on two guide bars with automatic connection to discharge.
- S Portable semi permanent, wet well arrangement with hose coupling or flange for connection to discharge pipeline.
- T Vertical permanent, dry well arrangement with flange connection to suction and discharge piping.
- Z Horizontal permanent, dry well arrangement with flange connection to suction and discharge piping.

## Application limits

Feature	Description
Liquid temperature	Maximum 40°C (104°F)
Depth of immersion	Maximum 20 m (65 ft)
pH of the pumped liquid	5.5 - 14
Liquid density	Maximum 1100 kg/m <sup>3</sup>

## Motor data

Feature	Description
Motor type	Squirrel-cage induction motor
Frequency	50 Hz
Power supply	3-phase
Starting method	<ul style="list-style-type: none"> <li>• Direct on-line</li> <li>• Star-delta</li> <li>• Variable Frequency Drive (VFD)</li> </ul>
Number of starts per hour	Maximum 30
Code compliance	IEC 60034-1
Rated output variation	±10%
Voltage variation	<ul style="list-style-type: none"> <li>• Continuously running: Maximum ±5%</li> <li>• Intermittent running: Maximum ±10%</li> </ul>
Voltage imbalance between phases	Maximum 2%
Stator insulation class	H (180°C, 356°F)

## Cables

Application	Type
Direct-on-line start or Y/D start with two cables	Flygt SUBCAB® - a heavy duty 4 cores motor power cable with two twisted pair screened control cores. Conductor insulation rating of 90°C, which allows for increased current. Superior mechanical strength and high abrasion and tear resistant. Chemical resistant within pH 3-10 and ozone, oil, and flame resistant. Used up to 70°C water temperature. Cables < 10 mm <sup>2</sup> with unscreened control cores.
Y/D start	Flygt SUBCAB® - a heavy duty 7 cores motor power cable with two twisted pair screened control cores. Conductor insulation rating of 90°C, which allows for increased current. Superior mechanical strength and high abrasion and tear resistant. Chemical resistant within pH 3-10 and ozone, oil, and flame resistant. Used up to 70°C water temperature. Cables < 7G6 mm <sup>2</sup> with unscreened control cores.
Variable Frequency drive	Screened Flygt SUBCAB® - a heavy duty 4 screened cores motor power cable with four twisted pair screened control cores. Conductor insulation rating of 90°C, which allows for increased current. Superior mechanical strength and high abrasion and tear resistant. Chemical resistant within pH 3-10 and ozone, oil, and flame resistant. Used up to 70°C water temperature.

## Monitoring equipment

- Thermal contacts opening temperature 140° C (284° F)
- Leakage sensor in the inspection chamber (FLS 10)

## Materials

Table 17: Major parts except mechanical seals

Denomination	Material	ASTM	EN
Major castings	Cast iron, gray	35B	GJL-250
Pump housing	Cast iron, gray	35B	GJL-250
Impeller, alternative 1	Cast iron, gray	35B	GJL-250
Impeller, alternative 2	Cast iron, Hard-Iron™	A 532 IIIA	GJN-HB555(XCR23)
Insert ring, alternative 1	Cast iron, gray	35B	GJL-250
Insert ring, alternative 2	Cast iron, Hard-Iron™	A 532 IIIA	GJN-HB555(XCR23)
Cooling jacket, inner	Aluminum	AA 1050A	AW-1050A
Cooling jacket, outer, alternative 1	Steel	GR65	S235JRG2
Cooling jacket, outer, alternative 2	Stainless steel	AISI 316L	1.4404,1.4432, ...
Lifting handle	Stainless steel	AISI 316L	1.4404,1.4432, ...
Shaft	Stainless steel	AISI 431	1.4057+QT800
Screws and nuts	Stainless steel, A4	AISI 316L, 316, 316Ti	1.4401,1.4404, ...
O-rings, alternative 1	Nitrile rubber (NBR) 70° IRH	-	-
O-rings, alternative 2	Fluorinated rubber (FPM) 70° IRH	-	-
Glycol	Heat transfer fluid based on monopropylene glycol. Fulfills FDA 184.1666/182.6285.	-	-

Table 18: Mechanical seals

Alternative	Inner seal	Outer seal
1	Corrosion resistant cemented carbide/ Corrosion resistant cemented carbide	Corrosion resistant cemented carbide/ Corrosion resistant cemented carbide
2	Corrosion resistant cemented carbide/ Corrosion resistant cemented carbide	Silicon carbide/ Silicon carbide

## Surface treatment

Priming	Finish
Painted with a primer, see internal standard M0700.00.0002	Navy gray color NCS 5804-B07G. Two-component high-solid top coating, see internal standard M0700.00.0004 for standard painting and M0700.00.0008 for special painting.

## Options

- Sensors: Thermistor, FLS, Pt 100, VIS 10
- Surface treatment (Epoxy)
- Zinc anodes
- Other cables

## Accessories

Discharge connections, adapters, hose connections, and other mechanical accessories.  
Electrical accessories such as pump controller, control panels, starters, monitoring relays, cables.

## Motor rating and performance curves

These are examples of motor rating and curves. For more information, please contact your local sales and service representative.

Star-delta starting current is 1/3 of Direct on-line starting current.

LT

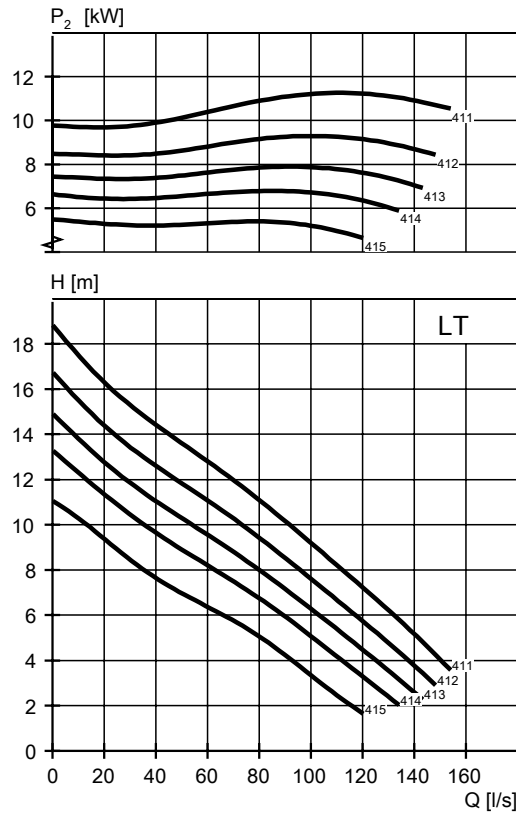

WS004090A

Table 19: 400 V, 50 Hz, 3-phase

Rated power, kW	Rated power, hp	Curve/ Impeller No	Revolutions per minute, rpm	Rated current, A	Starting current, A	Power factor, cos φ	Installation
12.5	16.8	411	1500	21	145	0.95	P,S,T,Z
12.5	16.8	412	1500	21	145	0.95	P,S,T,Z
12.5	16.8	413	1500	21	145	0.95	P,S,T,Z
12.5	16.8	414	1500	21	145	0.95	P,S,T,Z
12.5	16.8	415	1500	21	145	0.95	P,S,T,Z

MT

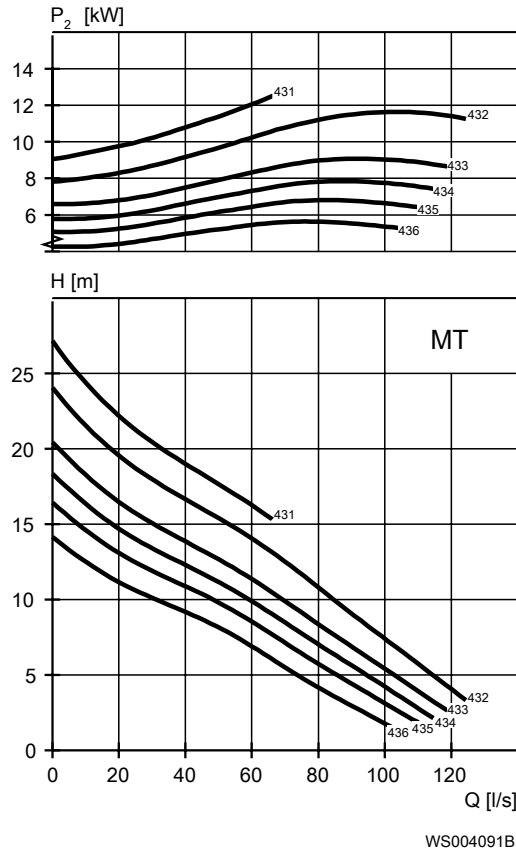

Table 20: 400 V, 50 Hz, 3-phase

Rated power, kW	Rated power, hp	Curve/ Impeller No	Revolutions per minute, rpm	Rated current, A	Starting current, A	Power factor, $\cos \varphi$	Installation
12.5	16.8	431	1500	21	145	0.95	P,S,T,Z
12.5	16.8	432	1500	21	145	0.95	P,S,T,Z
12.5	16.8	433	1500	21	145	0.95	P,S,T,Z
12.5	16.8	434	1500	21	145	0.95	P,S,T,Z
12.5	16.8	435	1500	21	145	0.95	P,S,T,Z
12.5	16.8	436	1500	21	145	0.95	P,S,T,Z

HT

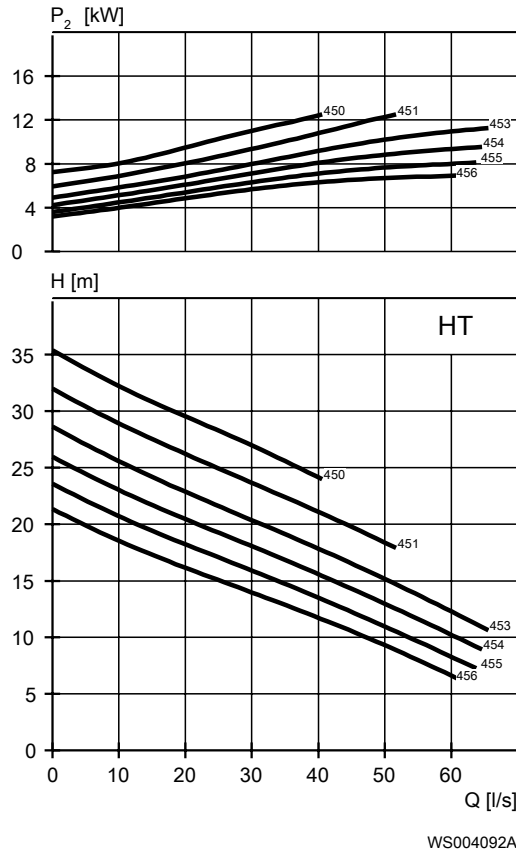
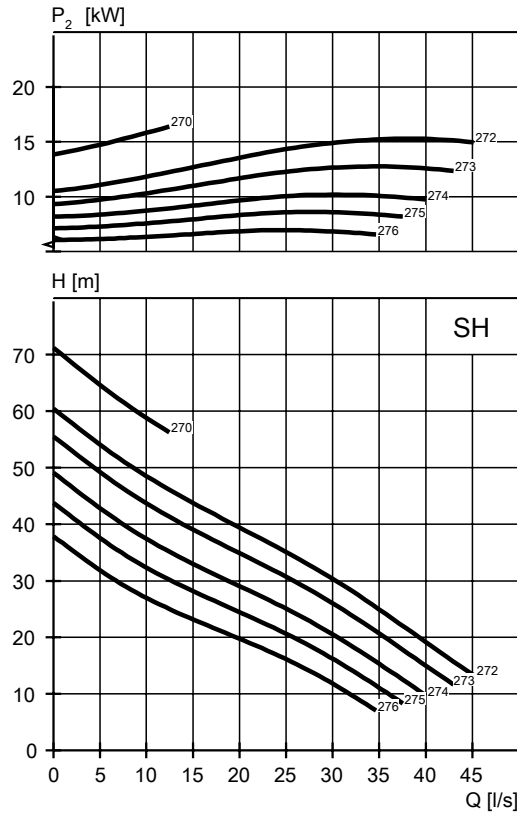

Table 21: 400 V, 50 Hz, 3-phase

Rated power, kW	Rated power, hp	Curve/ Impeller No	Revolutions per minute, rpm	Rated current, A	Starting current, A	Power factor, cos φ	Installation
12.5	16.8	450	1500	21	145	0.95	P,S,T,Z
12.5	16.8	451	1500	21	145	0.95	P,S,T,Z
12.5	16.8	453	1500	21	145	0.95	P,S,T,Z
12.5	16.8	454	1500	21	145	0.95	P,S,T,Z
12.5	16.8	455	1500	21	145	0.95	P,S,T,Z
12.5	16.8	456	1500	21	145	0.95	P,S,T,Z

SH



WS004093A

Table 22: 400 V, 50 Hz, 3-phase

IE3 compliance is based on Y-connected stator.

Rated power, kW	Rated power, hp	Curve/ Impeller No	Revolutions per minute, rpm	Rated current, A	Starting current, A	Power factor, $\cos \varphi$	Installation
16.4	22	270	3000	30	213	0.85	P,S,T,Z
16.4	22	272	3000	30	213	0.85	P,S,T,Z
16.4	22	273	3000	30	213	0.85	P,S,T,Z
16.4	22	274	3000	30	213	0.85	P,S,T,Z
16.4	22	275	3000	30	213	0.85	P,S,T,Z
16.4	22	276	3000	30	213	0.85	P,S,T,Z

# Dimensions and Weight

## Drawings

All drawings are available as Acrobat documents (.pdf) and AutoCad drawings (.dwg). Contact your local sales and service representative for more information.

All dimensions are in mm.

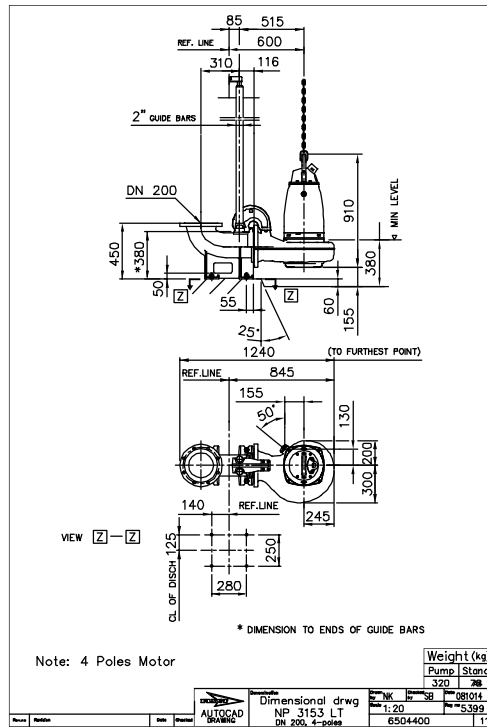

Figure 7: LT, P-installation

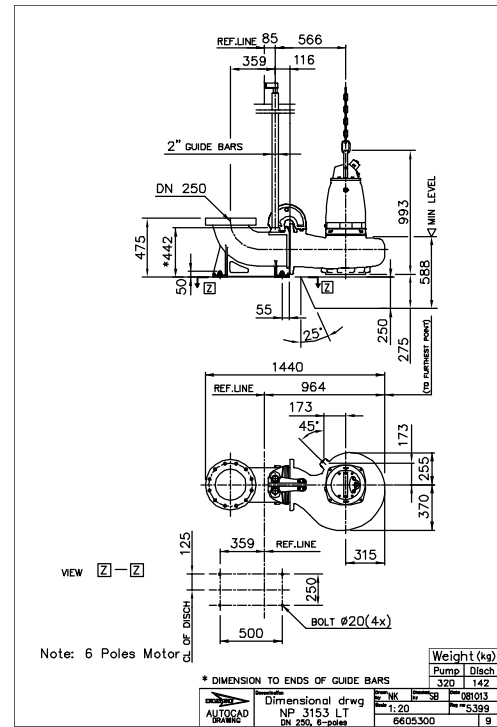

Figure 8: LT, P-installation

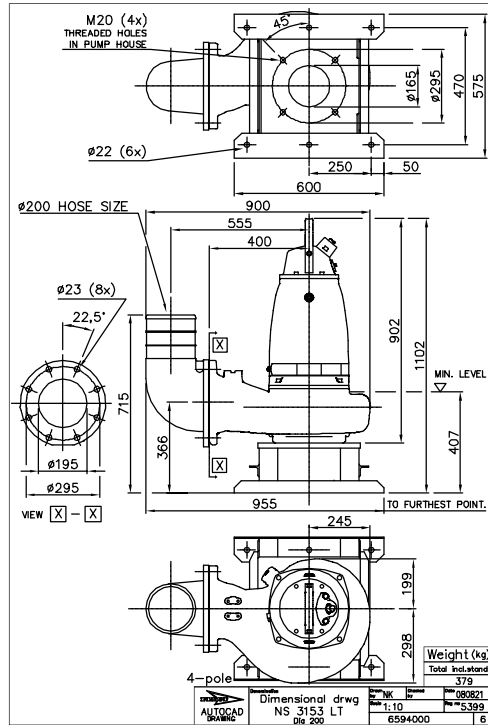

Figure 9: LT, S-installation

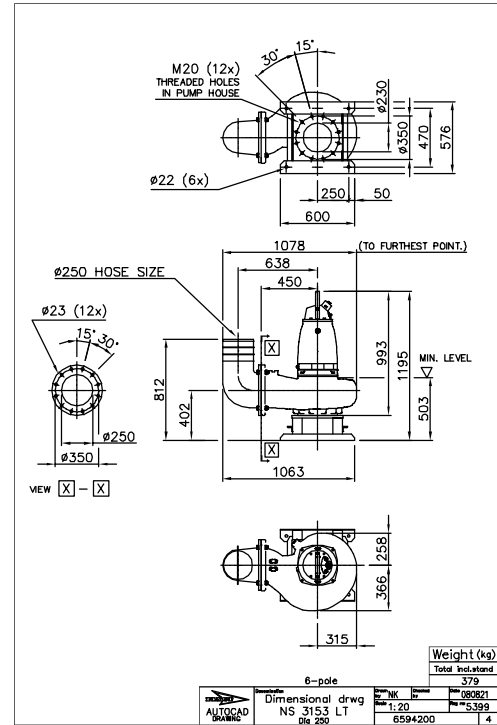

Figure 10: LT, S-installation

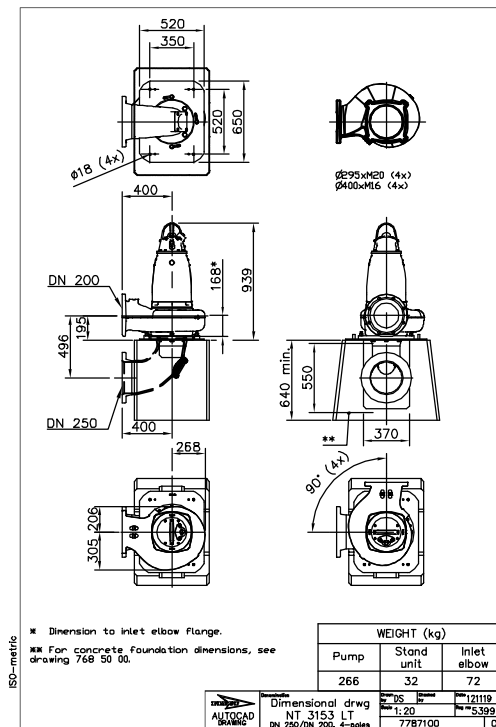

Figure 11: LT, T-installation

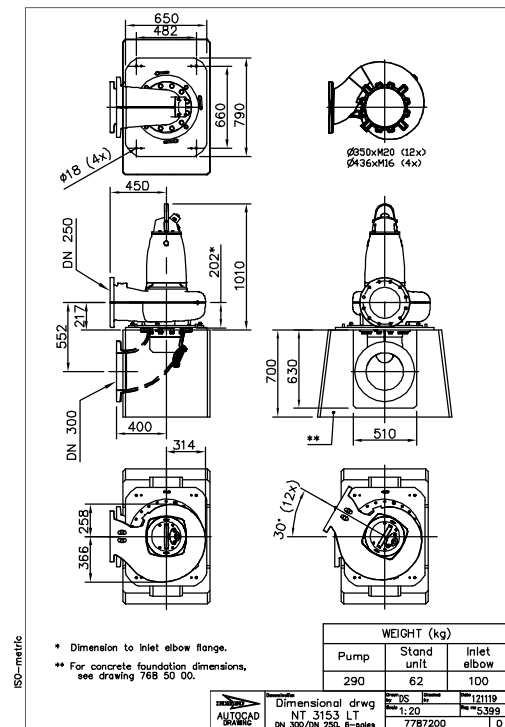

Figure 12: LT, T-installation

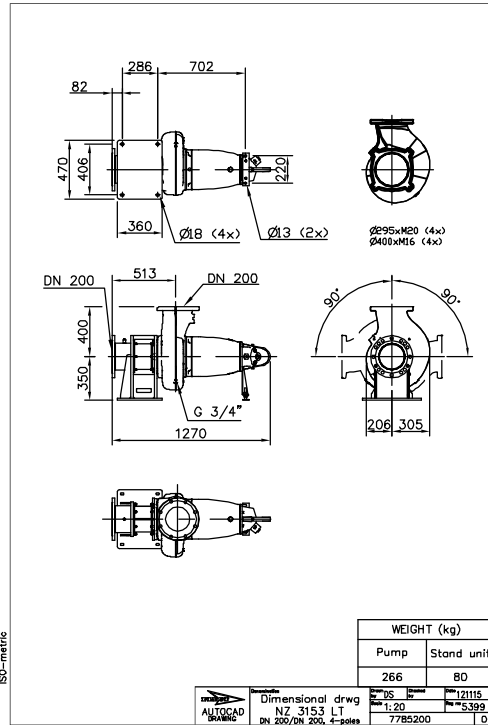

Figure 13: LT, Z-installation

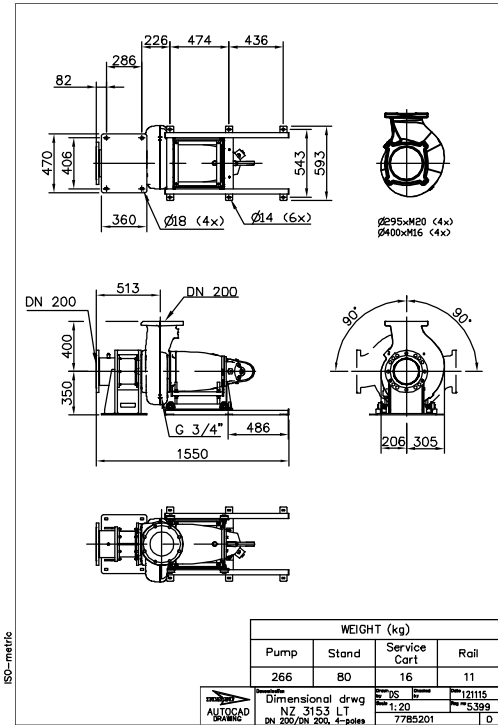

Figure 14: LT, Z-installation

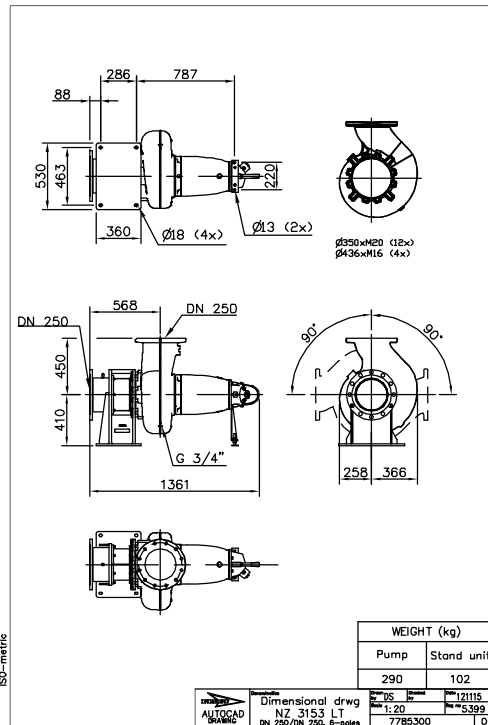

Figure 15: LT, Z-installation

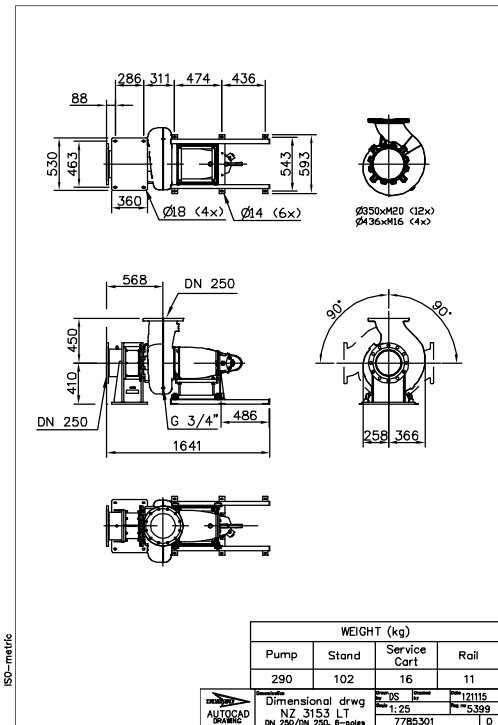

Figure 16: LT, Z-installation

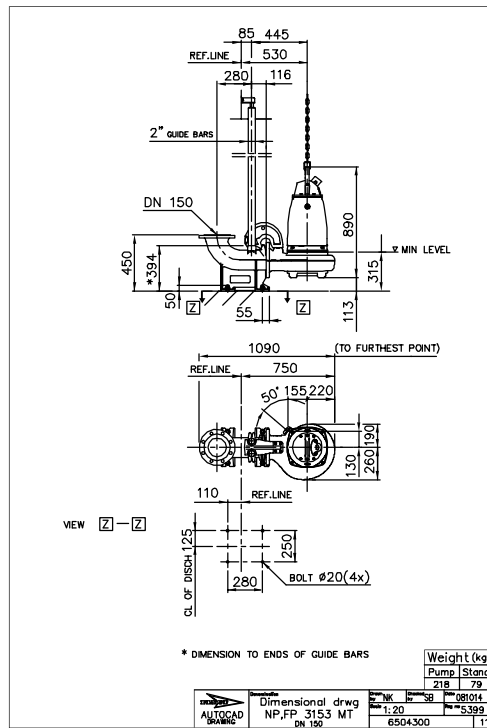

Figure 17: MT, P-installation

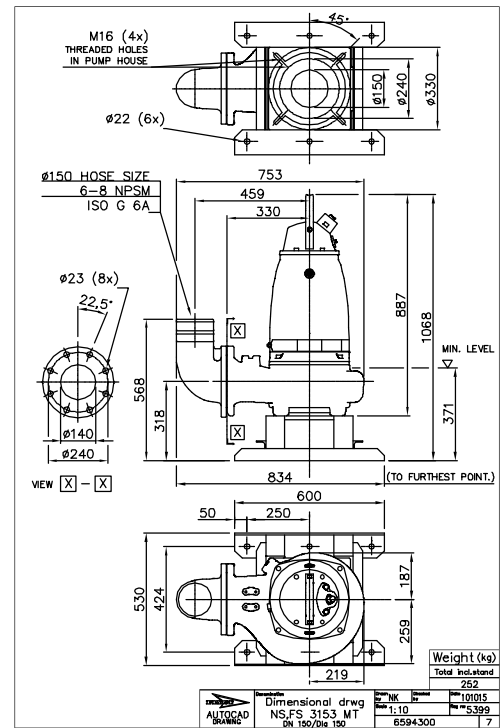

Figure 18: MT, S-installation

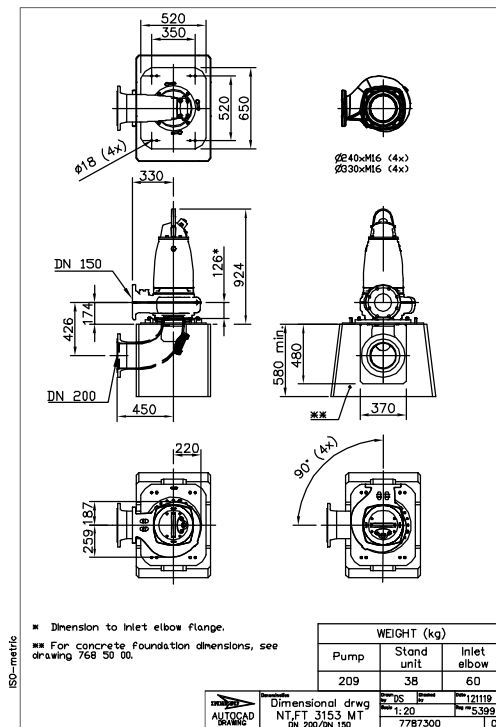

Figure 19: MT, T-installation

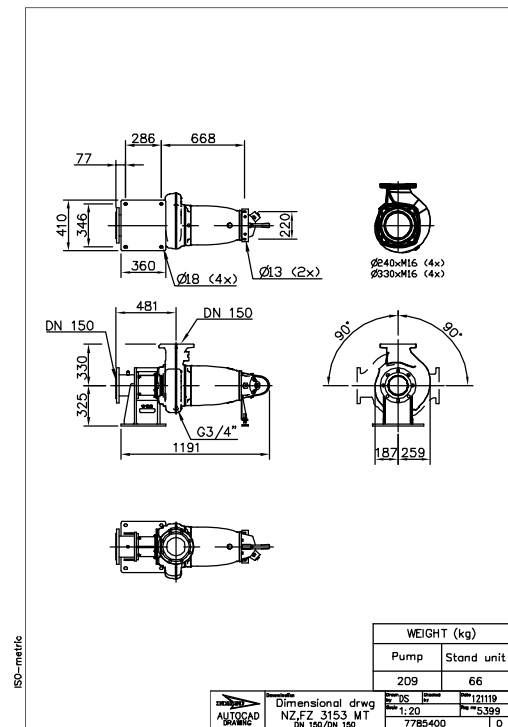

Figure 20: MT, Z-installation

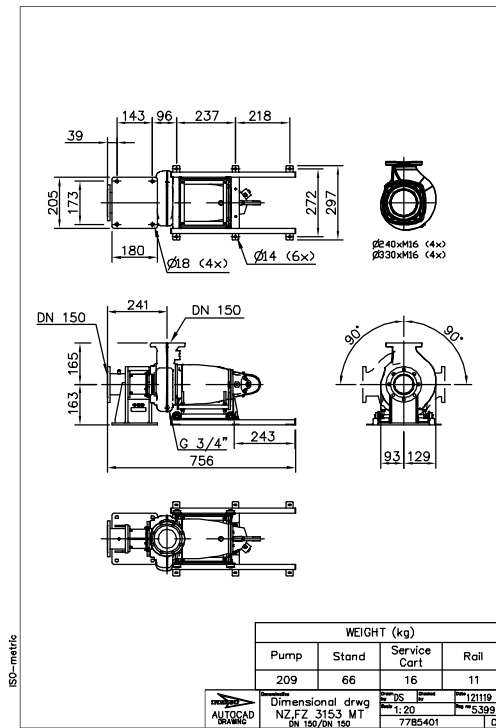

Figure 21: MT, Z-installation

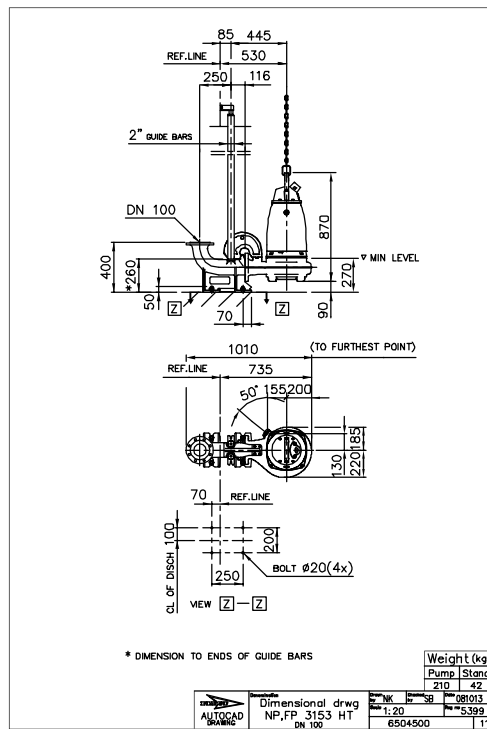

Figure 22: HT, P-installation

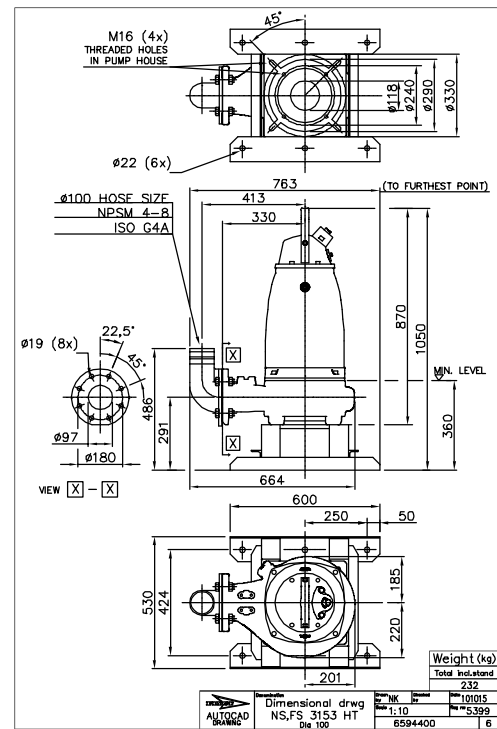

Figure 23: HT, S-installation

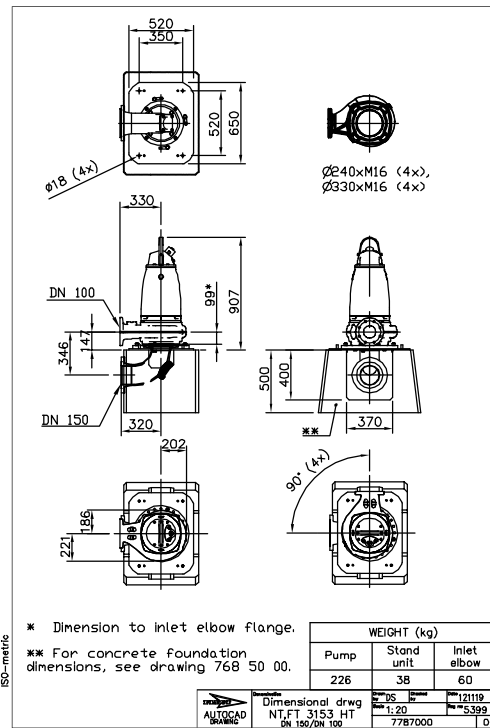

Figure 24: HT, T-installation

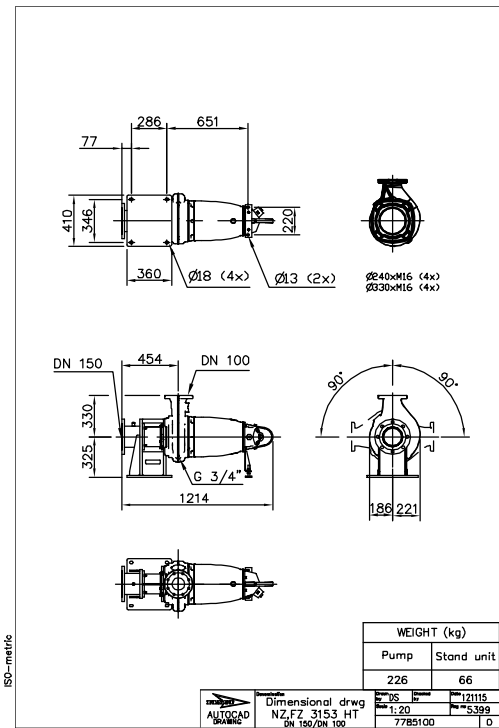

Figure 25: HT, Z-installation

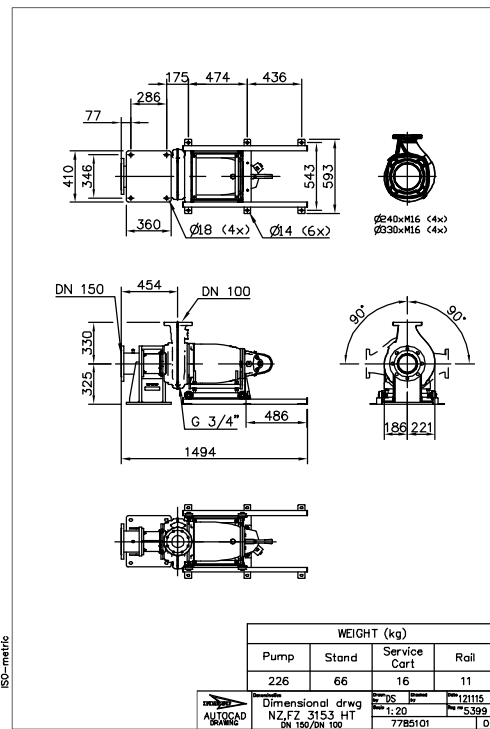

Figure 26: HT, Z-installation

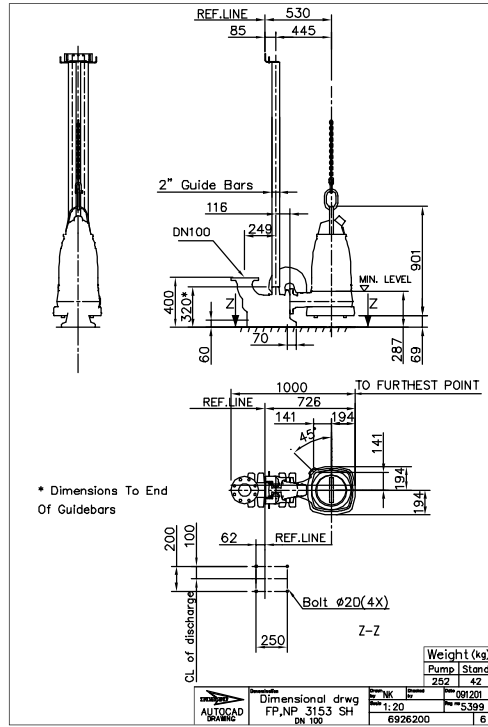

Figure 27: SH, P-installation

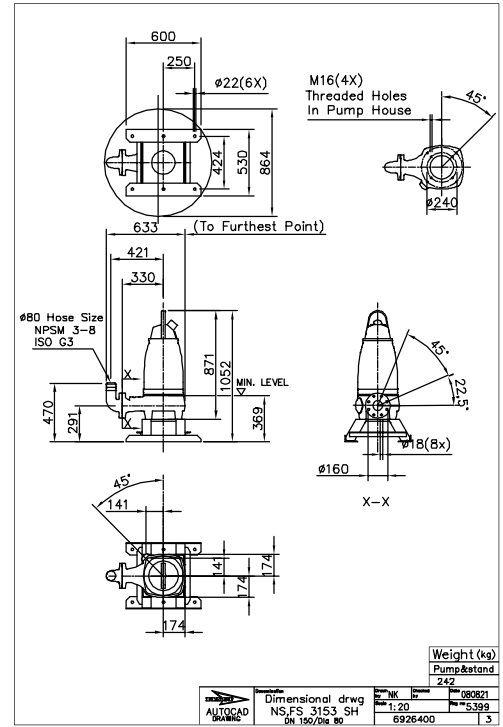

Figure 28: SH, S-installation

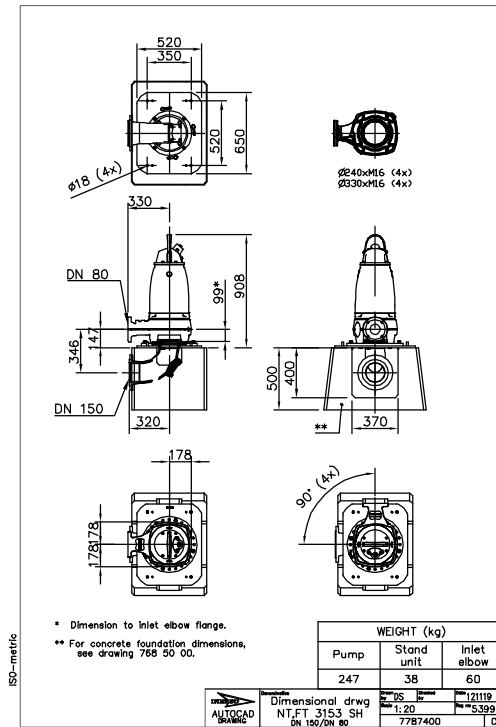

Figure 29: SH, T-installation

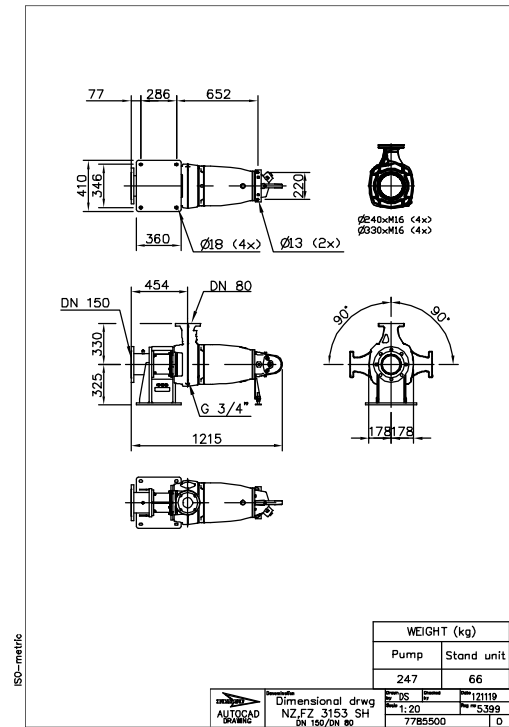

Figure 30: SH, Z-installation

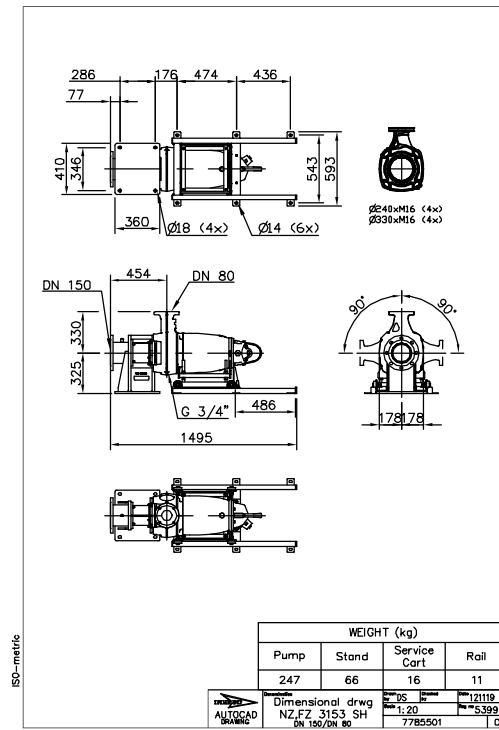

Figure 31: SH, Z-installation

# Xylem |'zīləm|

- 1) The tissue in plants that brings water upward from the roots
- 2) A leading global water technology company

We're 12,000 people unified in a common purpose: creating innovative solutions to meet our world's water needs. Developing new technologies that will improve the way water is used, conserved, and re-used in the future is central to our work. We move, treat, analyze, and return water to the environment, and we help people use water efficiently, in their homes, buildings, factories and farms. In more than 150 countries, we have strong, long-standing relationships with customers who know us for our powerful combination of leading product brands and applications expertise, backed by a legacy of innovation.

For more information on how Xylem can help you, go to [xyleminc.com](http://xyleminc.com)



Xylem Water Solutions  
Manufacturing AB  
361 80 Emmaboda  
Sweden  
Tel: +46-471-24 70 00  
Fax: +46-471-24 47 01  
<http://tpi.xyleminc.com>

Visit our Web site for the latest version of this document and more information

The original instruction is in English. All non-English instructions are translations of the original instruction.

© 2012 Xylem Inc