



Flygt 3102, 50Hz

Table of Contents

C-pump, Standard Motor	2
Product description.....	2
Motor rating and performance curves.....	4
C-pump, Premium Efficiency Motor (IE3)	6
Product description.....	6
Motor rating and performance curves.....	8
D-pump	10
Product description.....	10
Motor rating and performance curves.....	12
F-pump	15
Product description.....	15
Motor rating and performance curves.....	17
M-pump	19
Product description.....	19
Motor rating and performance curves.....	21
N-pump, Standard Motor	24
Product description.....	24
Motor rating and performance curves 3102.160/.190/.181/.090/.185/.095.....	27
Motor rating and performance curves 3102.760/.770.....	29
N-pump, Premium Efficiency Motor (IE3)	31
Product description.....	31
Motor rating and performance curves 3102.800/.810/.820/.830/.900/.910.....	34
Motor rating and performance curves 3102.960/.970.....	36
Dimensions and Weight, C-pump	38
Drawings.....	38
Dimensions and Weight, D-pump	44
Drawings.....	44
Dimensions and Weight, F-pump	46
Drawings.....	46
Dimensions and Weight, M-pump	48
Drawings.....	48
Dimensions and Weight, N-pump	50
Drawings.....	50

C-pump, Standard Motor

Product description



Usage

A submersible pump for wastewater containing solids or fibered material, clean water, or surface water.

Denomination

Type	Non-explosion proof version	Explosion proof version	Pressure class	Installation types
Cast iron	3102.181	3102.090	MT – Medium head	P, S, T, Z

The pump can be used in the following installations:

- P Semi permanent, wet well arrangement with pump installed on two guide bars with automatic connection to discharge.
- S Portable semi permanent, wet well arrangement with hose coupling or flange for connection to discharge pipeline.
- T Vertical permanent, dry well arrangement with flange connection to suction and discharge piping.
- Z Horizontal permanent, dry well arrangement with flange connection to suction and discharge piping.

Application limits

Feature	Description
Liquid temperature	Maximum 40°C (104°F)
Liquid temperature, warm water version	Maximum 70°C (158°F)
Depth of immersion	Maximum 20 m (65 ft)
pH of the pumped liquid	5.5 - 14
Liquid density	Maximum 1100 kg/m ³

Motor data

Feature	Description
Motor type	Squirrel-cage induction motor
Frequency	50 Hz

Feature	Description
Power supply	3-phase
Starting method	<ul style="list-style-type: none"> • Direct on-line • Star-delta • Soft starter • Variable Frequency Drive (VFD)
Number of starts per hour	Maximum 30
Code compliance	IEC 60034-1
Voltage variation	<ul style="list-style-type: none"> • Continuously running: Maximum $\pm 5\%$ • Intermittent running: Maximum $\pm 10\%$
Voltage imbalance between phases	Maximum 2%
Stator insulation class	H (180°C, 356°F)

Cables

Application	Type
Direct-on-line start or Y/D start with two cables	Flygt SUBCAB® - a heavy duty 4 cores motor power cable with two twisted pair screened control cores. Conductor insulation rating of 90°C, which allows for increased current. Superior mechanical strength and high abrasion and tear resistant. Chemical resistant within pH 3-10 and ozone, oil, and flame resistant. Used up to 70°C water temperature. Cables < 10 mm ² with unscreened control cores.
Y/D start	Flygt SUBCAB® - a heavy duty 7 cores motor power cable with two twisted pair screened control cores. Conductor insulation rating of 90°C, which allows for increased current. Superior mechanical strength and high abrasion and tear resistant. Chemical resistant within pH 3-10 and ozone, oil, and flame resistant. Used up to 70°C water temperature. Cables < 7G6 mm ² with unscreened control cores.
Variable Frequency drive	Screened Flygt SUBCAB® - a heavy duty 4 screened cores motor power cable with four twisted pair screened control cores. Conductor insulation rating of 90°C, which allows for increased current. Superior mechanical strength and high abrasion and tear resistant. Chemical resistant within pH 3-10 and ozone, oil, and flame resistant. Used up to 70°C water temperature.

Monitoring equipment

Thermal contacts opening temperature 125° C (257° F)

Materials

Table 1: Major parts except mechanical seals

Denomination	Material	ASTM	EN
Major castings	Cast iron, gray	35B	GJL-250
Pump housing, alternative 1	Cast iron, gray	35B	GJL-250
Pump housing, alternative 2	Cast iron, gray	ASTM A 48 NO 30B	GJL-200
Impeller	Cast iron, gray	35B	GJL-250
Wear ring, alternative 1	Rubber material, NBR	-	-

Denomination	Material	ASTM	EN
Wear ring, alternative 2	Bronze	C924	CC491K, CC492K
Lifting handle	Stainless steel	AISI 316L	1.4404, 1.4432, ...
Shaft	Stainless steel	AISI 431	1.4057+QT800
Screws and nuts	Stainless steel, A4	AISI 316L, 316, 316Ti	1.4401, 1.4404, ...
O-rings, alternative 1	Nitrile rubber (NBR) 70° IRH	-	-
O-rings, alternative 2	Fluorinated rubber (FPM) 70° IRH	-	-
Oil, part no 901752	Medical white oil of paraffin type. Fulfills FDA 172.878 (a)	-	-

Table 2: Mechanical seals

Alternative	Inner seal	Outer seal
1	Aluminum oxide/ Corrosion resistant cemented carbide	Aluminum oxide/ Corrosion resistant cemented carbide
2	Aluminum oxide/ Corrosion resistant cemented carbide	Corrosion resistant cemented carbide/ Corrosion resistant cemented carbide
3	Corrosion resistant cemented carbide/ Corrosion resistant cemented carbide	Aluminum oxide/ Corrosion resistant cemented carbide
4	Corrosion resistant cemented carbide/ Corrosion resistant cemented carbide	Corrosion resistant cemented carbide/ Corrosion resistant cemented carbide

Surface treatment

Priming	Finish
Painted with a primer, see internal standard M0700.00.0002	Navy gray color NCS 5804-B07G. Two-component high-solid top coating, see internal standard M0700.00.0004 for standard painting and M0700.00.0008 for special painting.

Options

- Warm liquid version (non-explosion proof versions)
- Leakage sensor in the stator housing (FLS)
- Leakage sensor in the oil housing (CLS)
- Surface treatment (Epoxy)
- Zinc anodes
- Other cables

Accessories

Discharge connections, adapters, hose connections, and other mechanical accessories.
Electrical accessories such as pump controller, control panels, starters, monitoring relays, cables.

Motor rating and performance curves

These are examples of motor rating and curves. For more information, please contact your local sales and service representative.

Star-delta starting current is 1/3 of Direct on-line starting current.

MT

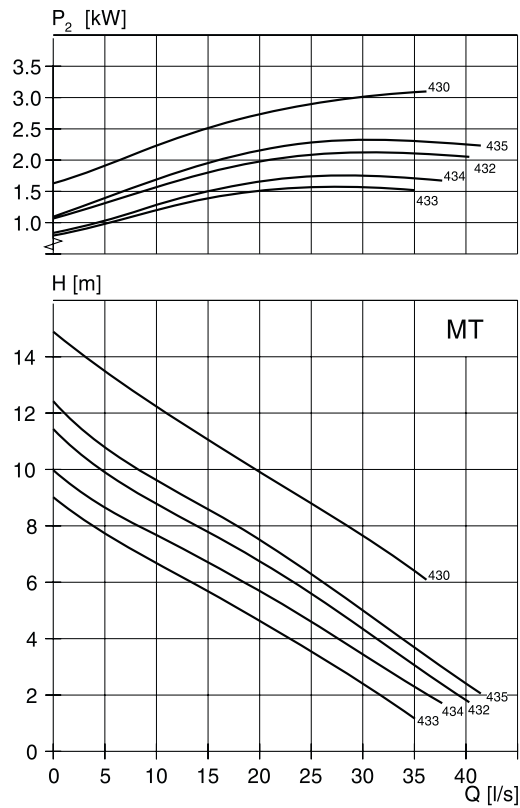

WS005029A

Table 3: 400 V, 50 Hz, 3-phase

Rated power, kW	Rated power, hp	Curve/ Impeller No	Revolutions per minute, rpm	Rated current, A	Starting current, A	Power factor, $\cos \varphi$	Installation
2.4	3.2	432	1455	5.1	33	0.8	T,Z
2.4	3.2	433	1455	5.1	33	0.8	T,Z
2.4	3.2	434	1455	5.1	33	0.8	T,Z
2.4	3.2	435	1455	5.1	33	0.8	T,Z
3.1	4.2	430	1440	6.3	33	0.85	P,S
3.1	4.2	432	1440	6.3	33	0.85	P,S
3.1	4.2	433	1440	6.3	33	0.85	P,S
3.1	4.2	434	1440	6.3	33	0.85	P,S
3.1	4.2	435	1440	6.3	33	0.85	P,S

C-pump, Premium Efficiency Motor (IE3)

Product description



Usage

A submersible pump for wastewater containing solids or fibered material, clean water, or surface water.

Denomination

Type	Non-explosion proof version	Explosion proof version	Pressure class	Installation types
Cast iron	3102.800	3102.810	• MT – Medium head	P, S, T, Z

The pump can be used in the following installations:

- P Semi permanent, wet well arrangement with pump installed on two guide bars with automatic connection to discharge.
- S Portable semi permanent, wet well arrangement with hose coupling or flange for connection to discharge pipeline.
- T Vertical permanent, dry well arrangement with flange connection to suction and discharge piping.
- Z Horizontal permanent, dry well arrangement with flange connection to suction and discharge piping.

Application limits

Feature	Description
Liquid temperature	Maximum 40°C (104°F)
Depth of immersion	Maximum 20 m (65 ft)
pH of the pumped liquid	5.5 - 14
Liquid density	Maximum 1100 kg/m ³

Motor data

Feature	Description
Motor type	Line started permanent magnet motor (LSPM)
Frequency	50 Hz
Power supply	3-phase
Starting method	<ul style="list-style-type: none"> • Direct on-line • Star-delta • Soft starter • Variable Frequency Drive (VFD)
Number of starts per hour	Maximum 30
Code compliance	IEC 60034-1
Voltage variation	<ul style="list-style-type: none"> • Continuously running: Maximum $\pm 5\%$ • Intermittent running: Maximum $\pm 10\%$
Voltage imbalance between phases	Maximum 2%
Stator insulation class	H (180°C, 356°F)

Cables

Application	Type
Direct-on-line start or Y/D start with two cables	Flygt SUBCAB® - a heavy duty 4 cores motor power cable with two twisted pair screened control cores. Conductor insulation rating of 90°C, which allows for increased current. Superior mechanical strength and high abrasion and tear resistant. Chemical resistant within pH 3-10 and ozone, oil, and flame resistant. Used up to 70°C water temperature. Cables < 10 mm ² with unscreened control cores.
Y/D start	Flygt SUBCAB® - a heavy duty 7 cores motor power cable with two twisted pair screened control cores. Conductor insulation rating of 90°C, which allows for increased current. Superior mechanical strength and high abrasion and tear resistant. Chemical resistant within pH 3-10 and ozone, oil, and flame resistant. Used up to 70°C water temperature. Cables < 7G6 mm ² with unscreened control cores.
Variable Frequency drive	Screened Flygt SUBCAB® - a heavy duty 4 screened cores motor power cable with four twisted pair screened control cores. Conductor insulation rating of 90°C, which allows for increased current. Superior mechanical strength and high abrasion and tear resistant. Chemical resistant within pH 3-10 and ozone, oil, and flame resistant. Used up to 70°C water temperature.

Monitoring equipment

Thermal contacts opening temperature 125° C (257° F)

Materials

Table 4: Major parts except mechanical seals

Denomination	Material	ASTM	EN
Major castings	Cast iron, gray	35B	GJL-250
Pump housing, alternative 1	Cast iron, gray	35B	GJL-250

Denomination	Material	ASTM	EN
Pump housing, alternative 2	Cast iron, gray	ASTM A 48 NO 30B	GJL-200
Impeller	Cast iron, gray	35B	GJL-250
Wear ring, alternative 1	Rubber material, NBR	-	-
Wear ring, alternative 2	Bronze	C924	CC491K, CC492K
Lifting handle	Stainless steel	AISI 316L	1.4404, 1.4432, ...
Shaft	Stainless steel	AISI 431	1.4057+QT800
Screws and nuts	Stainless steel, A4	AISI 316L, 316, 316Ti	1.4401, 1.4404, ...
O-rings, alternative 1	Nitrile rubber (NBR) 70° IRH	-	-
O-rings, alternative 2	Fluorinated rubber (FPM) 70° IRH	-	-
Oil, part no 901752	Medical white oil of paraffin type. Fulfills FDA 172.878 (a)	-	-

Table 5: Mechanical seals

Alternative	Inner seal	Outer seal
1	Aluminum oxide/ Corrosion resistant cemented carbide	Aluminum oxide/ Corrosion resistant cemented carbide
2	Aluminum oxide/ Corrosion resistant cemented carbide	Corrosion resistant cemented carbide/ Corrosion resistant cemented carbide
3	Corrosion resistant cemented carbide/ Corrosion resistant cemented carbide	Aluminum oxide/ Corrosion resistant cemented carbide
4	Corrosion resistant cemented carbide/ Corrosion resistant cemented carbide	Corrosion resistant cemented carbide/ Corrosion resistant cemented carbide

Surface treatment

Priming	Finish
Painted with a primer, see internal standard M0700.00.0002	Navy gray color NCS 5804-B07G. Two-component high-solid top coating, see internal standard M0700.00.0004 for standard painting and M0700.00.0008 for special painting.

Options

- Leakage sensor in the stator housing (FLS)
- Leakage sensor in the oil housing (CLS)
- Surface treatment (Epoxy)
- Zinc anodes
- Other cables

Accessories

Discharge connections, adapters, hose connections, and other mechanical accessories. Electrical accessories such as pump controller, control panels, starters, monitoring relays, cables.

Motor rating and performance curves

These are examples of motor rating and curves. For more information, please contact your local sales and service representative.

Star-delta starting current is 1/3 of Direct on-line starting current.

MT

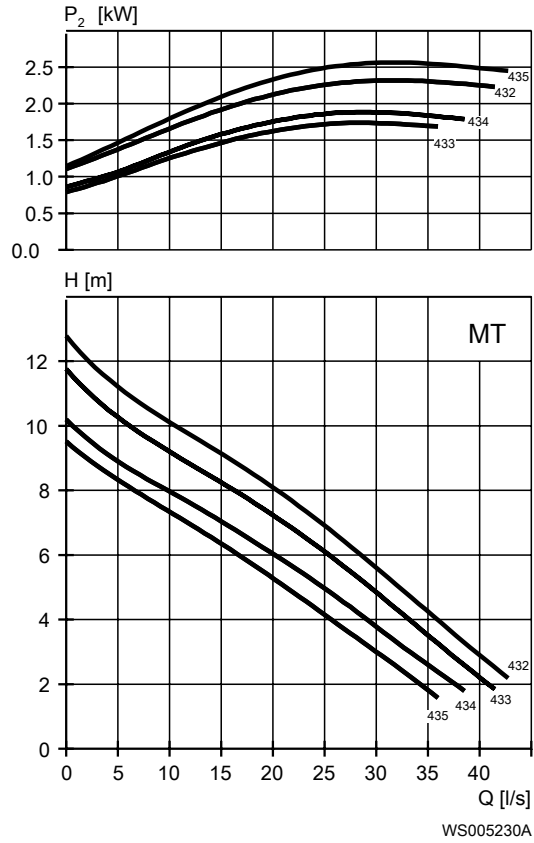

Table 6: 400 V, 50 Hz, 3-phase

Rated power, kW	Rated power, hp	Curve/ Impeller No	Revolutions per minute, rpm	Rated current, A	Starting current, A	Power factor, cos φ	Installation
3.5	4.7	432	1500	6.3	40	0.88	P,S,T,Z
3.5	4.7	433	1500	6.3	40	0.88	P,S,T,Z
3.5	4.7	434	1500	6.3	40	0.88	P,S,T,Z
3.5	4.7	435	1500	6.3	40	0.88	P,S,T,Z

D-pump

Product description



Usage

A submersible pump, with vortex hydraulic, for liquids containing solids and abrasive media, or light wastewater.

Denomination

Type	Non-explosion proof version	Explosion proof version	Pressure class	Installation types
Cast iron	3102.181	3102.090	<ul style="list-style-type: none"> • MT – Medium head • HT – High head 	P, T, Z

The pump can be used in the following installations:

- P Semi permanent, wet well arrangement with pump installed on two guide bars with automatic connection to discharge.
- T Vertical permanent, dry well arrangement with flange connection to suction and discharge piping.
- Z Horizontal permanent, dry well arrangement with flange connection to suction and discharge piping.

Application limits

Feature	Description
Liquid temperature	Maximum 40°C (104°F)
Liquid temperature, warm water version	Maximum 70°C (158°F)
Depth of immersion	Maximum 20 m (65 ft)
pH of the pumped liquid	5.5 - 14
Liquid density	Maximum 1100 kg/m ³

Motor data

Feature	Description
Motor type	Squirrel-cage induction motor
Frequency	50 Hz

Feature	Description
Power supply	3-phase
Starting method	<ul style="list-style-type: none"> • Direct on-line • Star-delta • Soft starter • Variable Frequency Drive (VFD)
Number of starts per hour	Maximum 30
Code compliance	IEC 60034-1
Voltage variation	<ul style="list-style-type: none"> • Continuously running: Maximum $\pm 5\%$ • Intermittent running: Maximum $\pm 10\%$
Voltage imbalance between phases	Maximum 2%
Stator insulation class	H (180°C, 356°F)

Cables

Application	Type
Direct-on-line start or Y/D start with two cables	Flygt SUBCAB® - a heavy duty 4 cores motor power cable with two twisted pair screened control cores. Conductor insulation rating of 90°C, which allows for increased current. Superior mechanical strength and high abrasion and tear resistant. Chemical resistant within pH 3-10 and ozone, oil, and flame resistant. Used up to 70°C water temperature. Cables < 10 mm ² with unscreened control cores.
Y/D start	Flygt SUBCAB® - a heavy duty 7 cores motor power cable with two twisted pair screened control cores. Conductor insulation rating of 90°C, which allows for increased current. Superior mechanical strength and high abrasion and tear resistant. Chemical resistant within pH 3-10 and ozone, oil, and flame resistant. Used up to 70°C water temperature. Cables < 7G6 mm ² with unscreened control cores.
Variable Frequency drive	Screened Flygt SUBCAB® - a heavy duty 4 screened cores motor power cable with four twisted pair screened control cores. Conductor insulation rating of 90°C, which allows for increased current. Superior mechanical strength and high abrasion and tear resistant. Chemical resistant within pH 3-10 and ozone, oil, and flame resistant. Used up to 70°C water temperature.

Monitoring equipment

Thermal contacts opening temperature 125° C (257° F)

Materials

Table 7: Major parts except mechanical seals

Denomination	Material	ASTM	EN
Major castings	Cast iron, gray	35B	GJL-250
Pump housing	Cast iron, gray	35B	GJL-250
Impeller	Cast iron, gray	35B	GJL-250
Lifting handle	Stainless steel	AISI 316L	1.4404, 1.4432, ...
Shaft	Stainless steel	AISI 431	1.4057+QT800
Screws and nuts	Stainless steel, A4	AISI 316L, 316, 316Ti	1.4401, 1.4404, ...

Denomination	Material	ASTM	EN
O-rings, alternative 1	Nitrile rubber (NBR) 70° IRH	-	-
O-rings, alternative 2	Fluorinated rubber (FPM) 70° IRH	-	-
Oil, part no 901752	Medical white oil of paraffin type. Fulfills FDA 172.878 (a)	-	-

Table 8: Mechanical seals

Alternative	Inner seal	Outer seal
1	Aluminum oxide/ Corrosion resistant cemented carbide	Aluminum oxide/ Corrosion resistant cemented carbide
2	Aluminum oxide/ Corrosion resistant cemented carbide	Corrosion resistant cemented carbide/ Corrosion resistant cemented carbide
3	Corrosion resistant cemented carbide/ Corrosion resistant cemented carbide	Aluminum oxide/ Corrosion resistant cemented carbide
4	Corrosion resistant cemented carbide/ Corrosion resistant cemented carbide	Corrosion resistant cemented carbide/ Corrosion resistant cemented carbide

Surface treatment

Priming	Finish
Painted with a primer, see internal standard M0700.00.0002	Navy gray color NCS 5804-B07G. Two-component high-solid top coating, see internal standard M0700.00.0004 for standard painting and M0700.00.0008 for special painting.

Options

- Warm liquid version (non-explosion proof versions)
- Leakage sensor in the stator housing (FLS)
- Leakage sensor in the oil housing (CLS)
- Surface treatment (Epoxy)
- Zinc anodes
- Other cables

Accessories

Discharge connections, adapters, hose connections, and other mechanical accessories. Electrical accessories such as pump controller, control panels, starters, monitoring relays, cables.

Motor rating and performance curves

These are examples of motor rating and curves. For more information, please contact your local sales and service representative.

Star-delta starting current is 1/3 of Direct on-line starting current.

MT

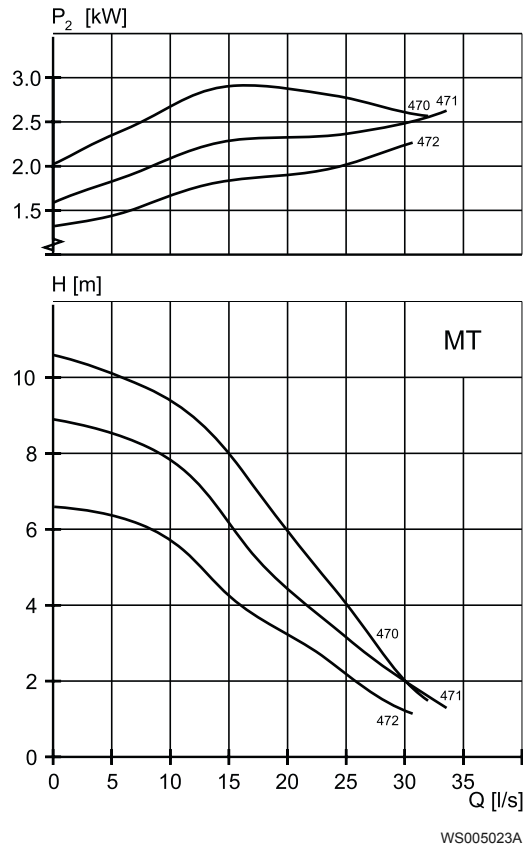

Table 9: 400 V, 50 Hz, 3-phase

Rated power, kW	Rated power, hp	Curve/ Impeller No	Revolutions per minute, rpm	Rated current, A	Starting current, A	Power factor, $\cos \phi$	Installation
3.1	4.2	470	1440	6.3	33	0.85	P
3.1	4.2	471	1440	6.3	33	0.85	P
3.1	4.2	472	1440	6.3	33	0.85	P

HT

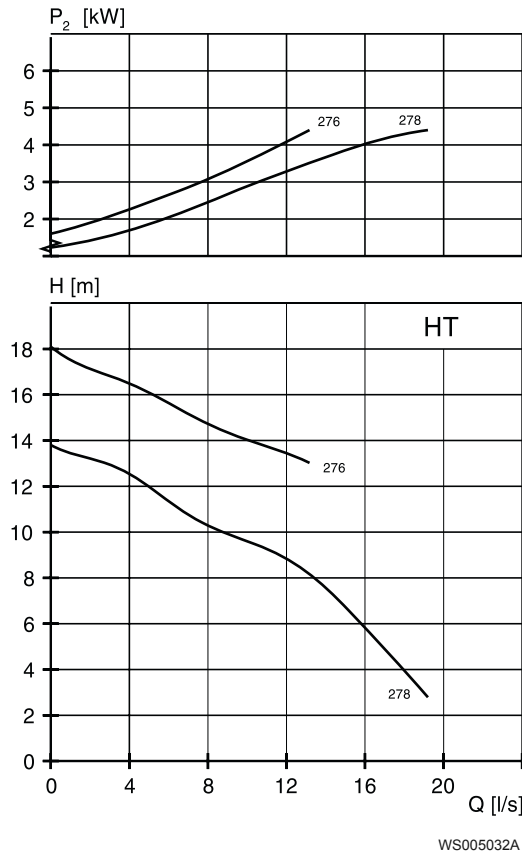

Table 10: 400 V, 50 Hz, 3-phase

Rated power, kW	Rated power, hp	Curve/ Impeller No	Revolutions per minute, rpm	Rated current, A	Start current, A	Power factor, cos φ	Installation
4.2	5.6	276	2900	8.2	74	0.87	P
4.2	5.6	276	2900	8.2	74	0.87	T,Z
4.2	5.6	276	2860	7.8	53	0.93	P
4.2	5.6	276	2860	7.8	53	0.93	T,Z
4.2	5.6	278	2900	8.2	74	0.87	P
4.2	5.6	278	2900	8.2	74	0.87	T,Z
4.2	5.6	278	2860	7.8	53	0.93	P
4.2	5.6	278	2860	7.8	53	0.93	T,Z

F-pump

Product description



Usage

A submersible pump for liquid manure, or heavily contaminated sewage and sludge. The impeller is S-shaped and has a cutting function.

Denomination

Type	Non-explosion proof version	Explosion proof version	Pressure class	Installation types
Chopper Cast iron	3102.181	3102.090	LT – Low head	P, S

The pump can be used in the following installations:

- P Semi permanent, wet well arrangement with pump installed on two guide bars with automatic connection to discharge.
- S Portable semi permanent, wet well arrangement with hose coupling or flange for connection to discharge pipeline.

Application limits

Feature	Description
Liquid temperature	Maximum 40°C (104°F)
Liquid temperature, warm water version	Maximum 70°C (158°F)
Depth of immersion	Maximum 20 m (65 ft)
pH of the pumped liquid	5.5 - 14
Liquid density	Maximum 1100 kg/m ³

Motor data

Feature	Description
Motor type	Squirrel-cage induction motor
Frequency	50 Hz
Power supply	3-phase

Feature	Description
Starting method	<ul style="list-style-type: none"> • Direct on-line • Star-delta • Soft starter • Variable Frequency Drive (VFD)
Number of starts per hour	Maximum 30
Code compliance	IEC 60034-1
Voltage variation	<ul style="list-style-type: none"> • Continuously running: Maximum $\pm 5\%$ • Intermittent running: Maximum $\pm 10\%$
Voltage imbalance between phases	Maximum 2%
Stator insulation class	H (180°C, 356°F)

Cables

Application	Type
Direct-on-line start or Y/D start with two cables	Flygt SUBCAB® - a heavy duty 4 cores motor power cable with two twisted pair screened control cores. Conductor insulation rating of 90°C, which allows for increased current. Superior mechanical strength and high abrasion and tear resistant. Chemical resistant within pH 3-10 and ozone, oil, and flame resistant. Used up to 70°C water temperature. Cables < 10 mm ² with unscreened control cores.
Y/D start	Flygt SUBCAB® - a heavy duty 7 cores motor power cable with two twisted pair screened control cores. Conductor insulation rating of 90°C, which allows for increased current. Superior mechanical strength and high abrasion and tear resistant. Chemical resistant within pH 3-10 and ozone, oil, and flame resistant. Used up to 70°C water temperature. Cables < 7G6 mm ² with unscreened control cores.
Variable Frequency drive	Screened Flygt SUBCAB® - a heavy duty 4 screened cores motor power cable with four twisted pair screened control cores. Conductor insulation rating of 90°C, which allows for increased current. Superior mechanical strength and high abrasion and tear resistant. Chemical resistant within pH 3-10 and ozone, oil, and flame resistant. Used up to 70°C water temperature.

Monitoring equipment

Thermal contacts opening temperature 125° C (257° F)

Materials

Table 11: Major parts except mechanical seals

Denomination	Material	ASTM	EN
Major castings	Cast iron, gray	35B	GJL-250
Pump housing	Cast iron, gray	35B	GJL-250
Impeller	Cast iron, nodular	-	GJS-400-18-LT
Suction cover	Cast iron, Hard-Iron™	A 532 IIIA	GJN-HB555(XCR23)
Lifting handle	Stainless steel	AISI 316L	1.4404, 1.4432, ...
Shaft	Stainless steel	AISI 431	1.4057+QT800
Screws and nuts	Stainless steel, A4	AISI 316L, 316, 316Ti	1.4401, 1.4404, ...

Denomination	Material	ASTM	EN
O-rings, alternative 1	Nitrile rubber (NBR) 70° IRH	-	-
O-rings, alternative 2	Fluorinated rubber (FPM) 70° IRH	-	-
Oil, part no 901752	Medical white oil of paraffin type. Fulfills FDA 172.878 (a)	-	-

Table 12: Mechanical seals

Alternative	Inner seal	Outer seal
1	Aluminum oxide/ Corrosion resistant cemented carbide	Aluminum oxide/ Corrosion resistant cemented carbide
2	Aluminum oxide/ Corrosion resistant cemented carbide	Corrosion resistant cemented carbide/ Corrosion resistant cemented carbide
3	Corrosion resistant cemented carbide/ Corrosion resistant cemented carbide	Aluminum oxide/ Corrosion resistant cemented carbide
4	Corrosion resistant cemented carbide/ Corrosion resistant cemented carbide	Corrosion resistant cemented carbide/ Corrosion resistant cemented carbide

Surface treatment

Priming	Finish
Painted with a primer, see internal standard M0700.00.0002	Navy gray color NCS 5804-B07G. Two-component high-solid top coating, see internal standard M0700.00.0004 for standard painting and M0700.00.0008 for special painting.

Options

- Warm liquid version (non-explosion proof versions)
- Leakage sensor in the stator housing (FLS)
- Leakage sensor in the oil housing (CLS)
- Surface treatment (Epoxy)
- Zinc anodes
- Other cables

Accessories

Discharge connections, adapters, hose connections, and other mechanical accessories.
Electrical accessories such as pump controller, control panels, starters, monitoring relays, cables.

Motor rating and performance curves

These are examples of motor rating and curves. For more information, please contact your local sales and service representative.

Star-delta starting current is 1/3 of Direct on-line starting current.

LT

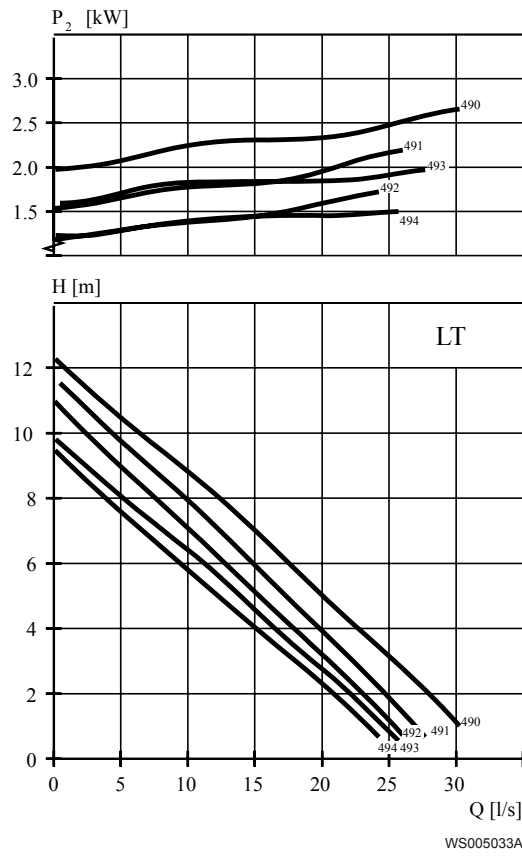

Table 13: 400 V, 50 Hz, 3-phase

Rated power, kW	Rated power, hp	Curve/ Impeller No	Revolutions per minute, rpm	Rated current, A	Starting current, A	Power factor, $\cos \varphi$	Installation
3.1	4.2	490	1440	6.3	33	0.85	P,S
3.1	4.2	491	1440	6.3	33	0.85	P,S
3.1	4.2	492	1440	6.3	33	0.85	P,S
3.1	4.2	493	1440	6.3	33	0.85	P,S
3.1	4.2	494	1440	6.3	33	0.85	P,S

M-pump

Product description



Usage

A submersible pump for wastewater containing solids that need to be macerated. The impeller is equipped with a grinder device.

Denomination

Type	Non-explosion proof version	Explosion proof version	Pressure class	Installation types
Cast iron Grinder	3102.170	3102.890	<ul style="list-style-type: none"> • LT – Low head • HT – High head 	F, H, P

The pump can be used in the following installations:

- F Free standing semi permanent, wet well arrangement where the pump is placed on a firm surface.
- H Semi permanent, wet well quick connection suspended arrangement, incorporating integral non-return valve.
- P Semi permanent, wet well arrangement with pump installed on two guide bars with automatic connection to discharge.

Application limits

Feature	Description
Liquid temperature	Maximum 40°C (104°F)
Depth of immersion	Maximum 20 m (65 ft)
pH of the pumped liquid	5.5 - 14
Liquid density	Maximum 1100 kg/m ³

Motor data

Feature	Description
Motor type	Squirrel-cage induction motor
Frequency	50 Hz
Power supply	3-phase

Feature	Description
Starting method	<ul style="list-style-type: none"> • Direct on-line • Star-delta • Soft starter
Number of starts per hour	Maximum 30
Code compliance	IEC 60034-1
Voltage variation	<ul style="list-style-type: none"> • Continuously running: Maximum $\pm 5\%$ • Intermittent running: Maximum $\pm 10\%$
Voltage imbalance between phases	Maximum 2%
Stator insulation class	H (180°C, 356°F)

Cables

Application	Type
Direct-on-line start or Y/D start with two cables	Flygt SUBCAB® - a heavy duty 4 cores motor power cable with two twisted pair screened control cores. Conductor insulation rating of 90°C, which allows for increased current. Superior mechanical strength and high abrasion and tear resistant. Chemical resistant within pH 3-10 and ozone, oil, and flame resistant. Used up to 70°C water temperature. Cables < 10 mm ² with unscreened control cores.
Y/D start	Flygt SUBCAB® - a heavy duty 7 cores motor power cable with two twisted pair screened control cores. Conductor insulation rating of 90°C, which allows for increased current. Superior mechanical strength and high abrasion and tear resistant. Chemical resistant within pH 3-10 and ozone, oil, and flame resistant. Used up to 70°C water temperature. Cables < 7G6 mm ² with unscreened control cores.

Monitoring equipment

Thermal contacts opening temperature 125° C (257° F)

Materials

Table 14: Major parts except mechanical seals

Denomination	Material	ASTM	EN
Major castings	Cast iron, gray	35B	GJL-250
Pump housing	Cast iron, gray	35B	GJL-250
Impeller	Cast iron, gray	30B	GJL-200
Cutter wheel	Cast iron, Hard-Iron™	A 532 IIIA	GJN-HB555(XCR23)
Cutter plate	Stainless steel	-	-
Lifting handle	Stainless steel	AISI 316L	1.4404, 1.4432, ...
Shaft	Stainless steel	AISI 431	1.4057+QT800
Screws and nuts	Stainless steel, A4	AISI 316L, 316, 316Ti	1.4401, 1.4404, ...
O-rings	Nitrile rubber (NBR) 70° IRH	-	-
Oil, part no 901752	Medical white oil of paraffin type. Fulfills FDA 172.878 (a)	-	-

Table 15: Mechanical seals

Alternative	Inner seal	Outer seal
1	Aluminum oxide/ Corrosion resistant cemented carbide	Aluminum oxide/ Corrosion resistant cemented carbide
2	Aluminum oxide/ Corrosion resistant cemented carbide	Corrosion resistant cemented carbide/ Corrosion resistant cemented carbide
3	Corrosion resistant cemented carbide/ Corrosion resistant cemented carbide	Aluminum oxide/ Corrosion resistant cemented carbide
4	Corrosion resistant cemented carbide/ Corrosion resistant cemented carbide	Corrosion resistant cemented carbide/ Corrosion resistant cemented carbide

Surface treatment

Priming	Finish
Painted with a primer, see internal standard M0700.00.0002	Navy gray color NCS 5804-B07G. Two-component high-solid top coating, see internal standard M0700.00.0004 for standard painting and M0700.00.0008 for special painting.

Options

- Leakage sensor in the stator housing (FLS)
- Leakage sensor in the oil housing (CLS)
- Surface treatment (Epoxy)
- Zinc anodes
- Other cables

Accessories

Discharge connections, adapters, hose connections, and other mechanical accessories.
Electrical accessories such as pump controller, control panels, starters, monitoring relays, cables.

Motor rating and performance curves

These are examples of motor rating and curves. For more information, please contact your local sales and service representative.

Star-delta starting current is 1/3 of Direct on-line starting current.

LT

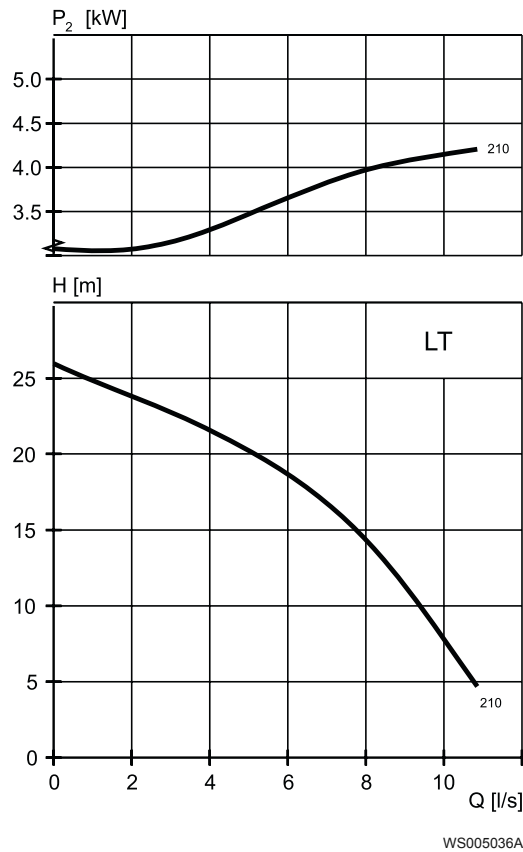

Table 16: 400 V, 50 Hz, 3-phase

Rated power, kW	Rated power, hp	Curve/ Impeller No	Revolutions per minute, rpm	Rated current, A	Starting current, A	Power factor, cos φ	Installation
4.4	5.9	210	2885	8.7	72	0.89	F,H,P
4.4	5.9	210	2840	8.6	52	0.94	F,H,P

HT

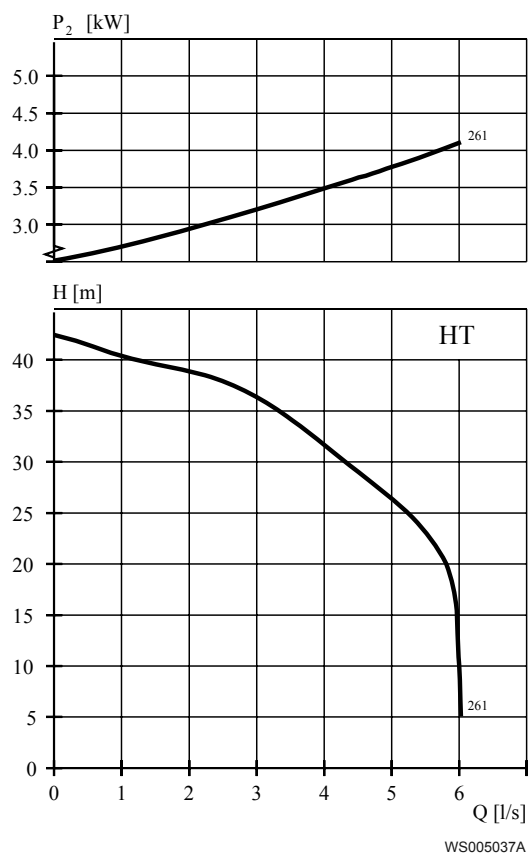

Table 17: 400 V, 50 Hz, 3-phase

Rated power, kW	Rated power, hp	Curve/ Impeller No	Revolutions per minute, rpm	Rated current, A	Starting current, A	Power factor, $\cos \varphi$	Installation
4.4	5.9	261	2885	8.7	72	0.89	F,H,P
4.4	5.9	261	2840	8.6	52	0.94	F,H,P

N-pump, Standard Motor

Product description



Usage

- Installation type P, S, T, Z A submersible pump for efficient pumping of clean water, surface water, and wastewater containing solids or long-fibered material. The pump is designed for sustained high efficiency. For abrasive media, Hard-Iron™ is required. Stainless steel N-impeller is available as an option.
- Installation type L A submersible pump for a mixed flow of clean water, surface water, or storm water. Intended for high flow and low head applications, in column installation. The pump is designed for sustained high efficiency.

Denomination

Type	Non-explosion proof version	Explosion proof version	Pressure class	Installation types
Adaptive	3102.160	3102.190	LT – Low head MT – Medium head SH – Super head	P, S, T, Z
Cast iron	3102.181	3102.090	LT – Low head MT – Medium head SH – Super head	L, P, S, T, Z
Hard-Iron™	3102.185	3102.095	LT – Low head MT – Medium head SH – Super head	P, S, T, Z
Stainless steel	3102.760	3102.770	Stainless steel	P, S

The pump can be used in the following installations:

- L Vertical semi permanent, wet well column pipe arrangement where the well is divided into a suction part and a discharge part. Pump end equipped with guide vanes.
- P Semi permanent, wet well arrangement with pump installed on two guide bars with automatic connection to discharge.

- S Portable semi permanent, wet well arrangement with hose coupling or flange for connection to discharge pipeline.
- T Vertical permanent, dry well arrangement with flange connection to suction and discharge piping.
- Z Horizontal permanent, dry well arrangement with flange connection to suction and discharge piping.

Application limits

Feature	Description
Liquid temperature	Maximum 40°C (104°F)
Liquid temperature, warm water version	Maximum 70°C (158°F)
Depth of immersion	Maximum 20 m (65 ft)
pH of the pumped liquid	5.5 - 14
Liquid density	Maximum 1100 kg/m ³

Motor data

Feature	Description
Motor type	Squirrel-cage induction motor
Frequency	50 Hz
Power supply	3-phase
Starting method	<ul style="list-style-type: none"> • Direct on-line • Star-delta • Soft starter • Variable Frequency Drive (VFD)
Number of starts per hour	Maximum 30
Code compliance	IEC 60034-1
Voltage variation	<ul style="list-style-type: none"> • Continuously running: Maximum $\pm 5\%$ • Intermittent running: Maximum $\pm 10\%$
Voltage imbalance between phases	Maximum 2%
Stator insulation class	H (180°C, 356°F)

Cables

Application	Type
Direct-on-line start or Y/D start with two cables	Flygt SUBCAB® - a heavy duty 4 cores motor power cable with two twisted pair screened control cores. Conductor insulation rating of 90°C, which allows for increased current. Superior mechanical strength and high abrasion and tear resistant. Chemical resistant within pH 3-10 and ozone, oil, and flame resistant. Used up to 70°C water temperature. Cables < 10 mm ² with unscreened control cores.
Y/D start	Flygt SUBCAB® - a heavy duty 7 cores motor power cable with two twisted pair screened control cores. Conductor insulation rating of 90°C, which allows for increased current. Superior mechanical strength and high abrasion and tear resistant. Chemical resistant within pH 3-10 and ozone, oil, and flame resistant. Used up to 70°C water temperature. Cables < 7G6 mm ² with unscreened control cores.

Application	Type
Variable Frequency drive	Screened Flygt SUBCAB® - a heavy duty 4 screened cores motor power cable with four twisted pair screened control cores. Conductor insulation rating of 90°C, which allows for increased current. Superior mechanical strength and high abrasion and tear resistant. Chemical resistant within pH 3-10 and ozone, oil, and flame resistant. Used up to 70°C water temperature.

Monitoring equipment

Thermal contacts opening temperature 125° C (257° F)

Materials

Table 18: Major parts except mechanical seals

Denomination	Material	ASTM	EN
Major castings	Cast iron, gray	35B	GJL-250
Pump housing, alternative 1	Cast iron, gray	35B	GJL-250
Pump housing, alternative 2	Cast iron, gray	ASTM A 48 NO 30B	GJL-200
Impeller Alternative 1	Cast iron, gray	35B	GJL-250
Impeller Alternative 2	Cast iron, Hard-Iron™	A 532 IIIA	GJN-HB555(XCR23)
Impeller Alternative 3	Stainless steel, Duplex	CD-4MCuN	10283:2010 -1.4474
Insert ring Alternative 1	Cast iron, gray	35B	GJL-250
Insert ring Alternative 2	Cast iron, Hard-Iron™	A 532 IIIA	GJN-HB555(XCR23)
Lifting handle	Stainless steel	AISI 316L	1.4404,1.4432, ...
Shaft	Stainless steel	AISI 431	1.4057+QT800
Screws and nuts	Stainless steel, A4	AISI 316L, 316, 316Ti	1.4401,1.4404, ...
O-rings, alternative 1	Nitrile rubber (NBR) 70° IRH	-	-
O-rings, alternative 2	Fluorinated rubber (FPM) 70° IRH	-	-
Oil, part no 901752	Medical white oil of paraffin type. Fulfills FDA 172.878 (a)	-	-

Table 19: Mechanical seals

Alternative	Inner seal	Outer seal
1	Aluminum oxide/ Corrosion resistant cemented carbide	Aluminum oxide/ Corrosion resistant cemented carbide
2	Aluminum oxide/ Corrosion resistant cemented carbide	Corrosion resistant cemented carbide/ Corrosion resistant cemented carbide
3	Corrosion resistant cemented carbide/ Corrosion resistant cemented carbide	Aluminum oxide/ Corrosion resistant cemented carbide
4	Corrosion resistant cemented carbide/ Corrosion resistant cemented carbide	Corrosion resistant cemented carbide/ Corrosion resistant cemented carbide

Surface treatment

Priming	Finish
Painted with a primer, see internal standard M0700.00.0002	Navy gray color NCS 5804-B07G. Two-component high-solid top coating, see internal standard M0700.00.0004 for standard painting and M0700.00.0008 for special painting.

Options

- Warm liquid version (non-explosion proof versions)
- Leakage sensor in the stator housing (FLS)
- Leakage sensor in the oil housing (CLS)
- Surface treatment (Epoxy)
- Zinc anodes
- Other cables

Accessories

Discharge connections, adapters, hose connections, and other mechanical accessories.
Electrical accessories such as pump controller, control panels, starters, monitoring relays, cables.

Motor rating and performance curves

3102.160/.190/.181/.090/.185/.095

These are examples of motor rating and curves. For more information, please contact your local sales and service representative.

Star-delta starting current is 1/3 of Direct on-line starting current.

LT

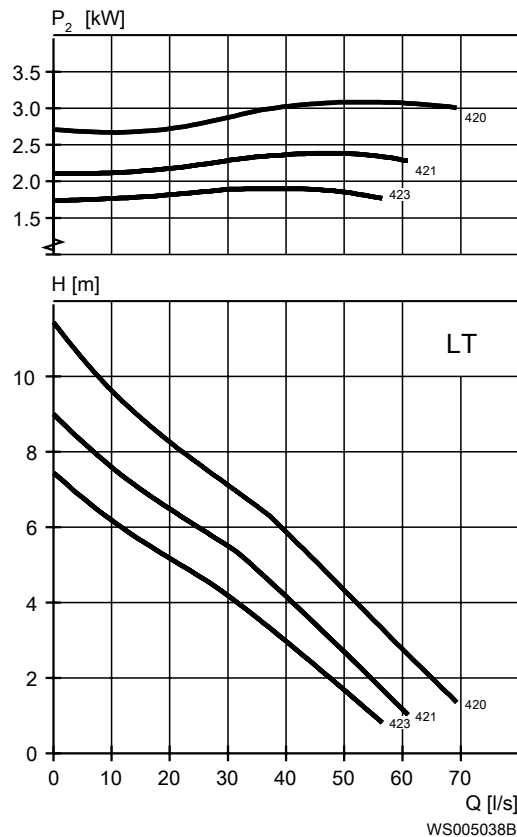

Table 20: 400 V, 50 Hz, 3-phase

Rated power, kW	Rated power, hp	Curve/ Impeller No	Revolutions per minute, rpm	Rated current, A	Starting current, A	Power factor, cos φ	Installation
2.4	3.2	421	1460	5.7	40	0.71	T,Z
2.4	3.2	423	1460	5.7	40	0.71	T,Z
3.1	4.2	420	1450	6.8	40	0.78	P,S
3.1	4.2	421	1450	6.8	40	0.78	P,S
3.1	4.2	423	1450	6.8	40	0.78	P,S

MT

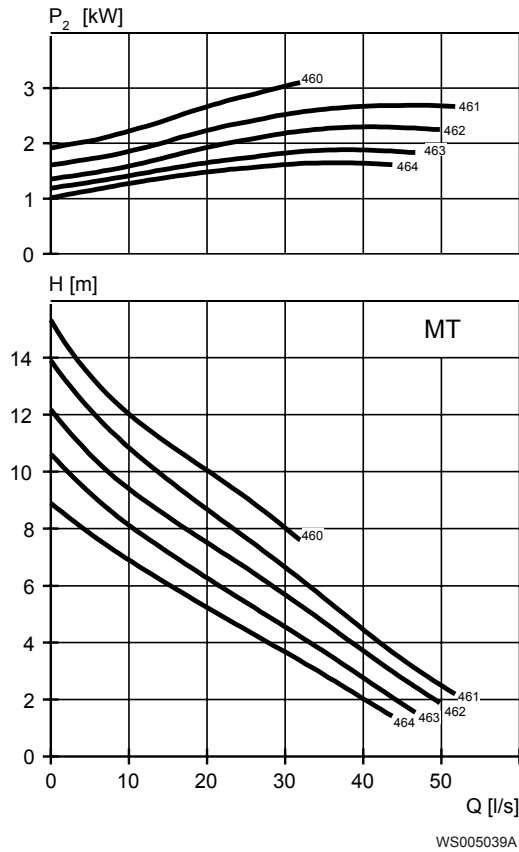

Table 21: 400 V, 50 Hz, 3-phase

Rated power, kW	Rated power, hp	Curve/ Impeller No	Revolutions per minute, rpm	Rated current, A	Starting current, A	Power factor, cos φ	Installation
2.4	3.2	462	1460	5.7	40	0.71	T,Z
2.4	3.2	463	1460	5.7	40	0.71	T,Z
2.4	3.2	464	1460	5.7	40	0.71	T,Z
3.1	4.2	460	1450	6.8	40	0.78	P,S
3.1	4.2	461	1450	6.8	40	0.78	P,S
3.1	4.2	462	1450	6.8	40	0.78	P,S
3.1	4.2	463	1450	6.8	40	0.78	P,S
3.1	4.2	464	1450	6.8	40	0.78	P,S

SH

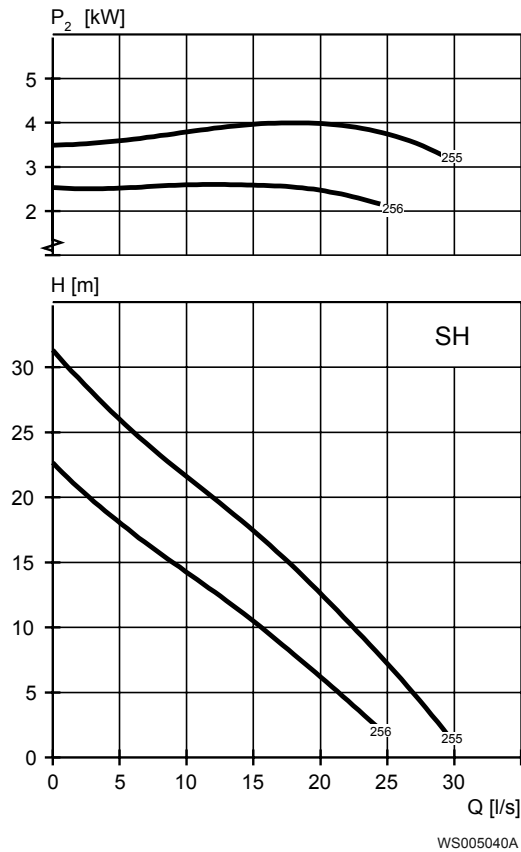

Table 22: 400 V, 50 Hz, 3-phase

Rated power, kW	Rated power, hp	Curve/ Impeller No	Revolutions per minute, rpm	Rated current, A	Starting current, A	Power factor, $\cos \varphi$	Installation
4.2	5.6	255	2900	8.2	74	0.87	P,S
4.2	5.6	255	2900	8.2	74	0.87	T,Z
4.2	5.6	255	2860	7.8	53	0.93	T,Z
4.2	5.6	255	2860	7.8	53	0.93	P,S
4.2	5.6	256	2900	8.2	74	0.87	T,Z
4.2	5.6	256	2900	8.2	74	0.87	P,S
4.2	5.6	256	2860	7.8	53	0.93	T,Z
4.2	5.6	256	2860	7.8	53	0.93	P,S

Motor rating and performance curves 3102.760/.770

These are examples of motor rating and curves. For more information, please contact your local sales and service representative.

Star-delta starting current is 1/3 of Direct on-line starting current.

MT

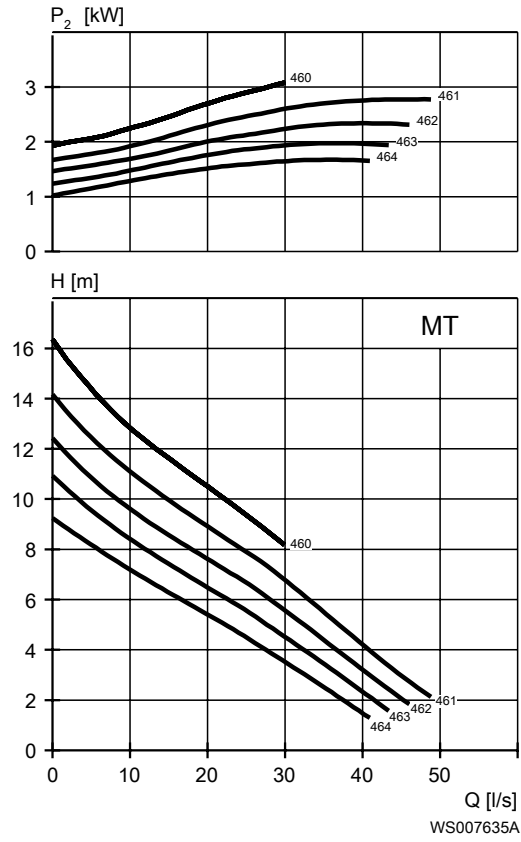

Table 23: 400 V, 50 Hz, 3-phase

Rated power, kW	Rated power, hp	Curve/ Impeller No	Revolutions per minute, rpm	Rated Current, A	Start current, A	Power Factor, cos φ	Installation
3.1	4.2	460	1450	6.8	40	0.78	P,S
3.1	4.2	460	1440	6.3	33	0.85	P,S
3.1	4.2	461	1450	6.8	40	0.78	P,S
3.1	4.2	461	1440	6.3	33	0.85	P,S
3.1	4.2	462	1450	6.8	40	0.78	P,S
3.1	4.2	462	1440	6.3	33	0.85	P,S
3.1	4.2	463	1450	6.8	40	0.78	P,S
3.1	4.2	463	1440	6.3	33	0.85	P,S
3.1	4.2	464	1450	6.8	40	0.78	P,S
3.1	4.2	464	1440	6.3	33	0.85	P,S

N-pump, Premium Efficiency Motor (IE3)

Product description



Usage

A submersible pump for efficient pumping of clean water, surface water, and wastewater containing solids or long-fibered material. The pump is designed for sustained high efficiency. For abrasive media, Hard-Iron™ is required. Stainless steel N-impeller is available as an option.

Denomination

Type	Non-explosion proof version	Explosion proof version	Pressure class	Installation types
Adaptive	3102.900	3102.910	LT – Low head MT – Medium head SH – Super head	P, S, T, Z
Cast iron	3102.800	3102.810	LT – Low head MT – Medium head SH – Super head	P, S, T, Z
Hard-Iron™	3102.820	3102.830	LT – Low head MT – Medium head SH – Super head	P, S, T, Z
Stainless steel	3102.960	3102.970	MT – Medium head	P, S

The pump can be used in the following installations:

- P Semi permanent, wet well arrangement with pump installed on two guide bars with automatic connection to discharge.
- S Portable semi permanent, wet well arrangement with hose coupling or flange for connection to discharge pipeline.
- T Vertical permanent, dry well arrangement with flange connection to suction and discharge piping.
- Z Horizontal permanent, dry well arrangement with flange connection to suction and discharge piping.

Application limits

Feature	Description
Liquid temperature	Maximum 40°C (104°F)
Depth of immersion	Maximum 20 m (65 ft)
pH of the pumped liquid	5.5 - 14
Liquid density	Maximum 1100 kg/m ³

Motor data

Feature	Description
Motor type	Line started permanent magnet motor (LSPM)
Frequency	50 Hz
Power supply	3-phase
Starting method	<ul style="list-style-type: none"> • Direct on-line • Star-delta • Soft starter • Variable Frequency Drive (VFD)
Number of starts per hour	Maximum 30
Code compliance	IEC 60034-1
Voltage variation	<ul style="list-style-type: none"> • Continuously running: Maximum $\pm 5\%$ • Intermittent running: Maximum $\pm 10\%$
Voltage imbalance between phases	Maximum 2%
Stator insulation class	H (180°C, 356°F)

Cables

Application	Type
Direct-on-line start or Y/D start with two cables	Flygt SUBCAB® - a heavy duty 4 cores motor power cable with two twisted pair screened control cores. Conductor insulation rating of 90°C, which allows for increased current. Superior mechanical strength and high abrasion and tear resistant. Chemical resistant within pH 3-10 and ozone, oil, and flame resistant. Used up to 70°C water temperature. Cables < 10 mm ² with unscreened control cores.
Y/D start	Flygt SUBCAB® - a heavy duty 7 cores motor power cable with two twisted pair screened control cores. Conductor insulation rating of 90°C, which allows for increased current. Superior mechanical strength and high abrasion and tear resistant. Chemical resistant within pH 3-10 and ozone, oil, and flame resistant. Used up to 70°C water temperature. Cables < 7G6 mm ² with unscreened control cores.
Variable Frequency drive	Screened Flygt SUBCAB® - a heavy duty 4 screened cores motor power cable with four twisted pair screened control cores. Conductor insulation rating of 90°C, which allows for increased current. Superior mechanical strength and high abrasion and tear resistant. Chemical resistant within pH 3-10 and ozone, oil, and flame resistant. Used up to 70°C water temperature.

Monitoring equipment

Thermal contacts opening temperature 125° C (257° F)

Materials

Table 24: Major parts except mechanical seals

Denomination	Material	ASTM	EN
Major castings	Cast iron, gray	35B	GJL-250
Pump housing, alternative 1	Cast iron, gray	35B	GJL-250
Pump housing, alternative 2	Cast iron, gray	ASTM A 48 NO 30B	GJL-200
Impeller, alternative 1	Cast iron, gray	35B	GJL-250
Impeller, alternative 2	Cast iron, Hard-Iron™	A 532 IIIA	GJN-HB555(XCR23)
Impeller, alternative 3	Stainless steel, Duplex	CD-4MCuN	10283:2010 -1.4474
Insert ring, alternative 1	Cast iron, gray	35B	GJL-250
Insert ring, alternative 2	Cast iron, Hard-Iron™	A 532 IIIA	GJN-HB555(XCR23)
Lifting handle	Stainless steel	AISI 316L	1.4404, 1.4432, ...
Shaft	Stainless steel	AISI 431	1.4057+QT800
Screws and nuts	Stainless steel, A4	AISI 316L, 316, 316Ti	1.4401, 1.4404, ...
O-rings, alternative 1	Nitrile rubber (NBR) 70° IRH	-	-
O-rings, alternative 2	Fluorinated rubber (FPM) 70° IRH	-	-
Oil, part no 901752	Medical white oil of paraffin type. Fulfills FDA 172.878 (a)	-	-

Table 25: Mechanical seals

Alternative	Inner seal	Outer seal
1	Aluminum oxide/ Corrosion resistant cemented carbide	Aluminum oxide/ Corrosion resistant cemented carbide
2	Aluminum oxide/ Corrosion resistant cemented carbide	Corrosion resistant cemented carbide/ Corrosion resistant cemented carbide
3	Corrosion resistant cemented carbide/ Corrosion resistant cemented carbide	Aluminum oxide/ Corrosion resistant cemented carbide
4	Corrosion resistant cemented carbide/ Corrosion resistant cemented carbide	Corrosion resistant cemented carbide/ Corrosion resistant cemented carbide

Surface treatment

Priming	Finish
Painted with a primer, see internal standard M0700.00.0002	Navy gray color NCS 5804-B07G. Two-component high-solid top coating, see internal standard M0700.00.0004 for standard painting and M0700.00.0008 for special painting.

Options

- Leakage sensor in the stator housing (FLS)
- Leakage sensor in the oil housing (CLS)
- Surface treatment (Epoxy)
- Zinc anodes
- Other cables

Accessories

Discharge connections, adapters, hose connections, and other mechanical accessories.
 Electrical accessories such as pump controller, control panels, starters, monitoring relays, cables.

Motor rating and performance curves 3102.800/.810/.820/.830/.900/.910

These are examples of motor rating and curves. For more information, please contact your local sales and service representative.

Star-delta starting current is 1/3 of Direct on-line starting current.

LT

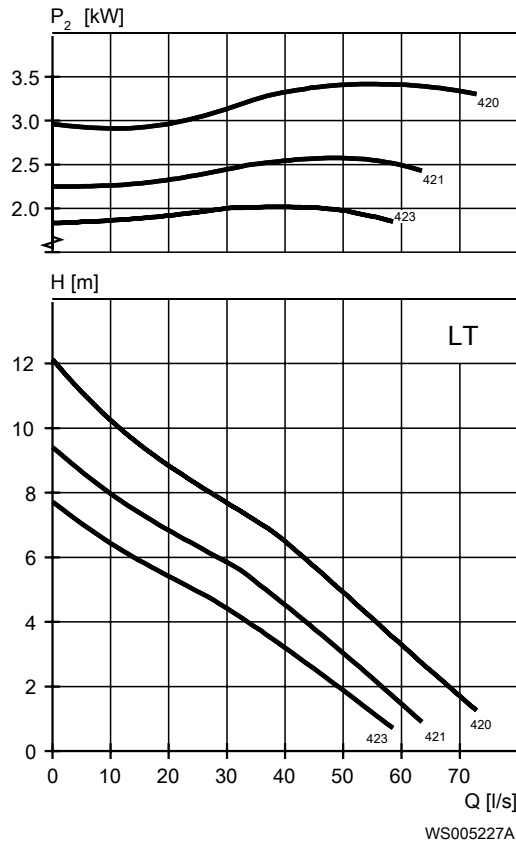

Table 26: 400 V, 50 Hz, 3-phase

Rated power, kW	Rated power, hp	Curve/ Impeller No	Revolutions per minute, rpm	Rated current, A	Starting current, A	Power factor, cos φ	Installation
3.5	4.7	420	1500	6.3	40	0.88	P,S,T,Z
3.5	4.7	421	1500	6.3	40	0.88	P,S,T,Z
3.5	4.7	423	1500	6.3	40	0.88	P,S,T,Z

MT

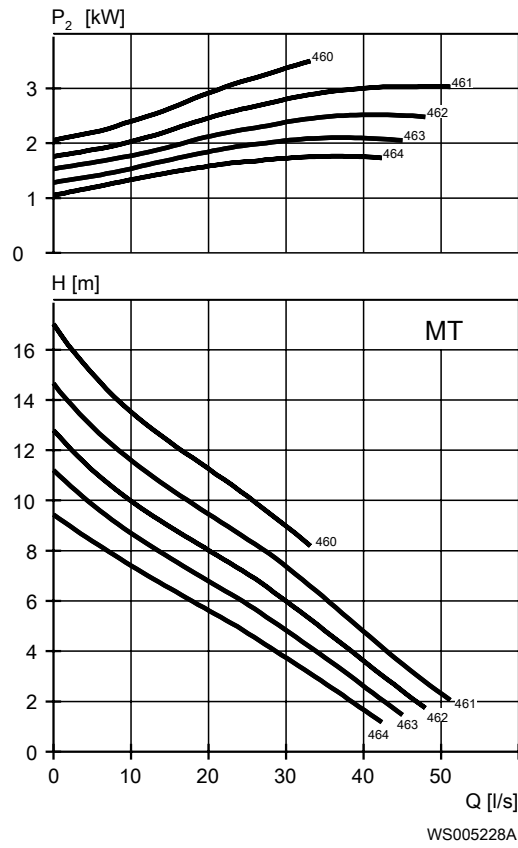

Table 27: 400 V, 50 Hz, 3-phase

Rated power, kW	Rated power, hp	Curve/ Impeller No	Revolutions per minute, rpm	Rated current, A	Starting current, A	Power factor, cos φ	Installation
3.5	4.7	460	1500	6.3	40	0.88	P,S,T,Z
3.5	4.7	461	1500	6.3	40	0.88	P,S,T,Z
3.5	4.7	462	1500	6.3	40	0.88	P,S,T,Z
3.5	4.7	463	1500	6.3	40	0.88	P,S,T,Z
3.5	4.7	464	1500	6.3	40	0.88	P,S,T,Z

SH

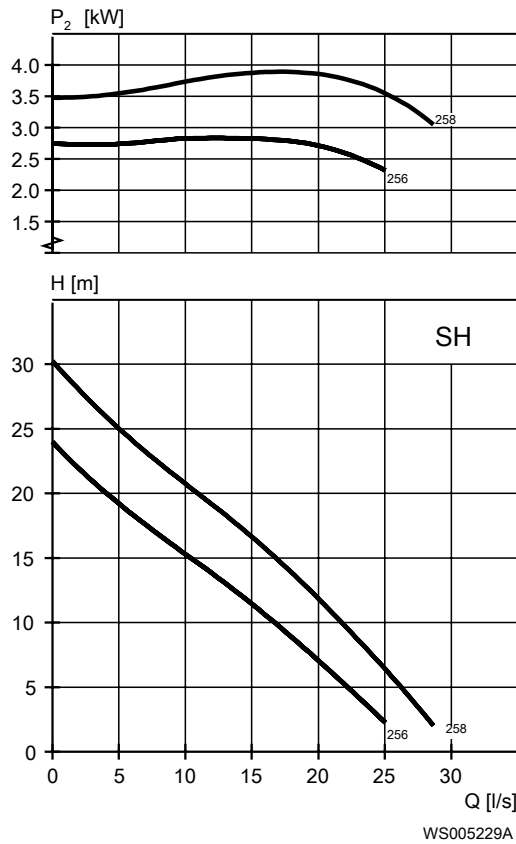

Table 28: 400 V, 50 Hz, 3-phase

IE3 compliance is based on Y-connected stator.

Rated power, kW	Rated power, hp	Curve/ Impeller No	Revolutions per minute, rpm	Rated current, A	Starting current, A	Power factor, cos φ	Installation
4.5	6	256	3000	8.5	64	0.86	P,S
4.5	6	256	3000	8.5	64	0.86	T,Z
4.5	6	258	3000	8.5	64	0.86	P,S
4.5	6	258	3000	8.5	64	0.86	T,Z

Motor rating and performance curves 3102.960/.970

These are examples of motor rating and curves. For more information, please contact your local sales and service representative.

Star-delta starting current is 1/3 of Direct on-line starting current.

MT

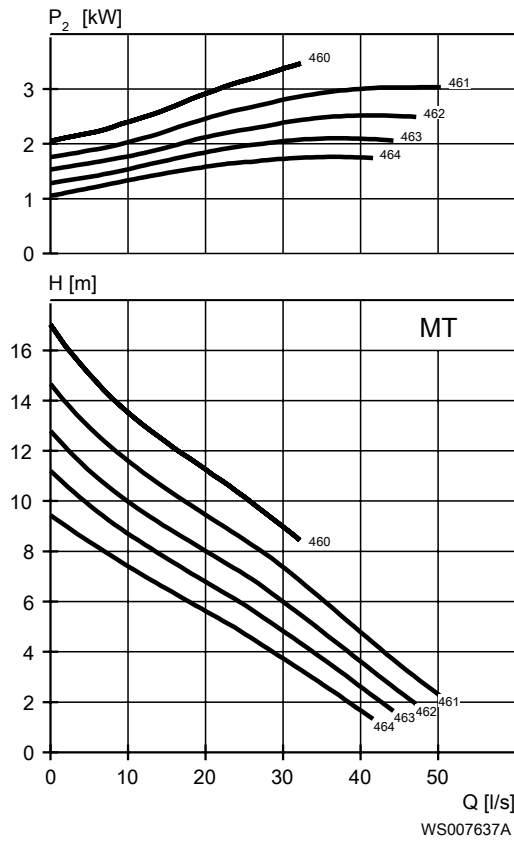

Table 29: 400 V, 50 Hz, 3-phase

Rated power, kW	Rated power, hp	Curve/ Impeller No	Revolutions per minute, rpm	Rated Current, A	Start current, A	Power Factor, $\cos \varphi$	Installation
3.5	4.7	460	1500	6.3	40	0.88	P,S
3.5	4.7	460	1500	6.0	33	0.93	P,S
3.5	4.7	461	1500	6.3	40	0.88	P,S
3.5	4.7	461	1500	6.0	33	0.93	P,S
3.5	4.7	462	1500	6.3	40	0.88	P,S
3.5	4.7	462	1500	6.0	33	0.93	P,S
3.5	4.7	463	1500	6.3	40	0.88	P,S
3.5	4.7	463	1500	6.0	33	0.93	P,S
3.5	4.7	464	1500	6.3	40	0.88	P,S
3.5	4.7	464	1500	6.0	33	0.93	P,S

Dimensions and Weight, C-pump

Drawings

All drawings are available as Acrobat documents (.pdf) and AutoCad drawings (.dwg). Contact your local sales and service representative for more information.

All dimensions are in mm.

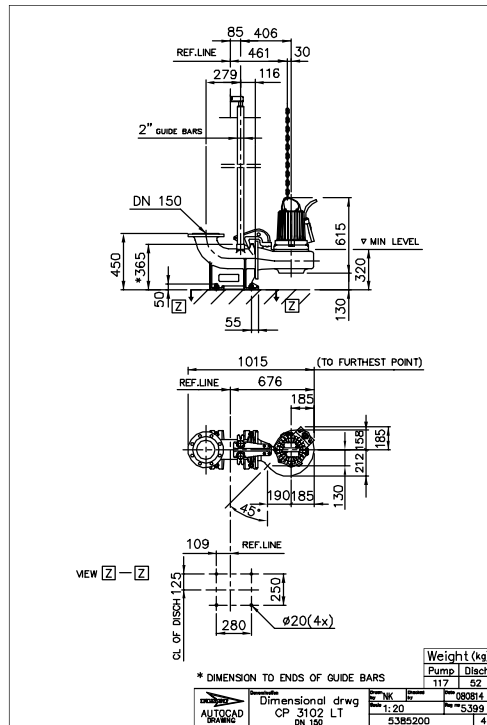

Figure 1: LT, P-installation

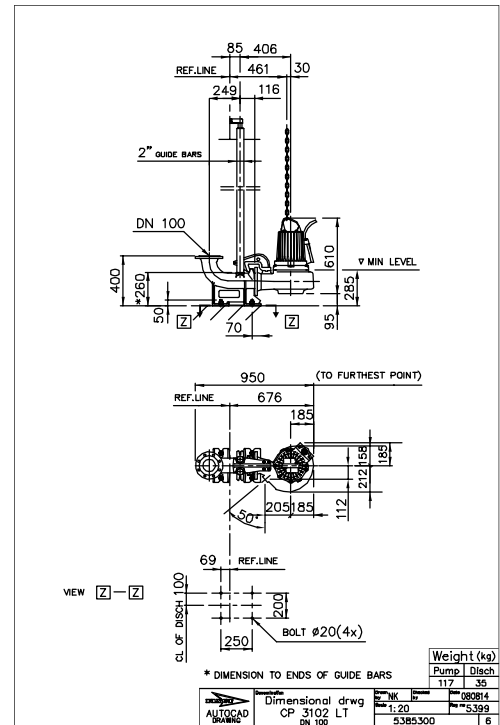

Figure 2: LT, P-installation

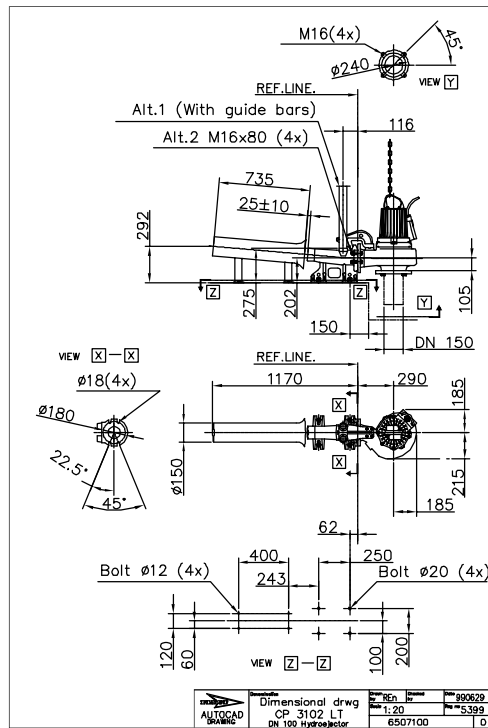

Figure 3: LT, P-installation

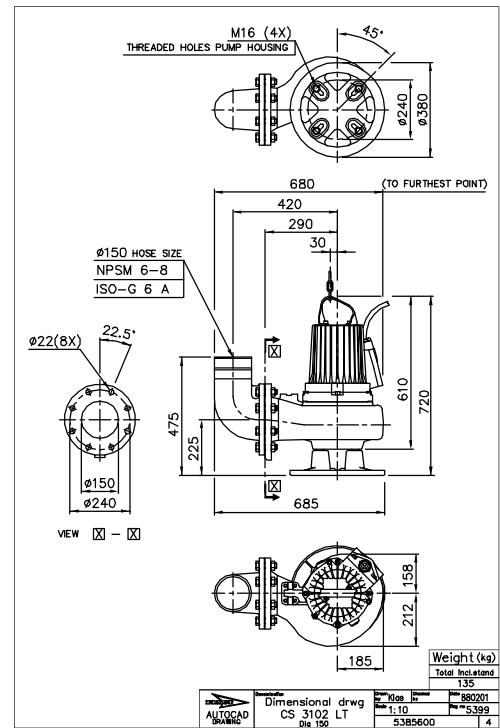

Figure 4: LT, S-installation

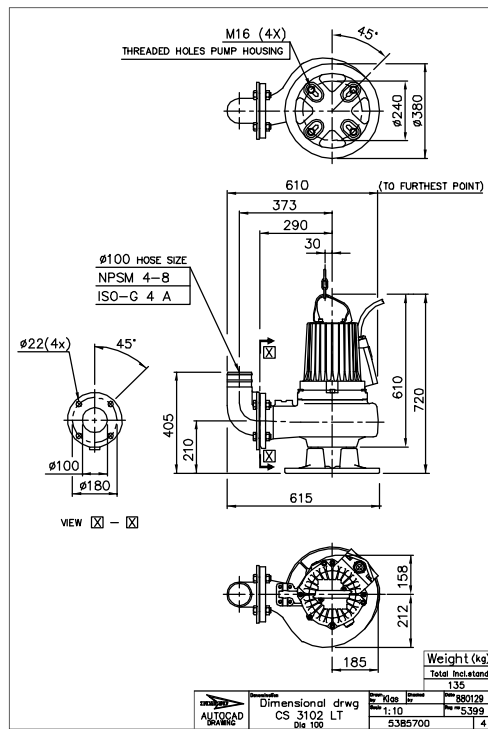

Figure 5: LT, S-installation

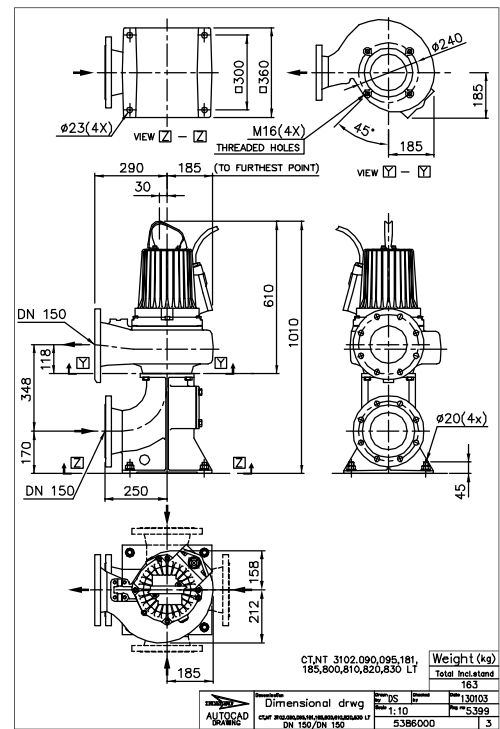

Figure 6: LT, T-installation

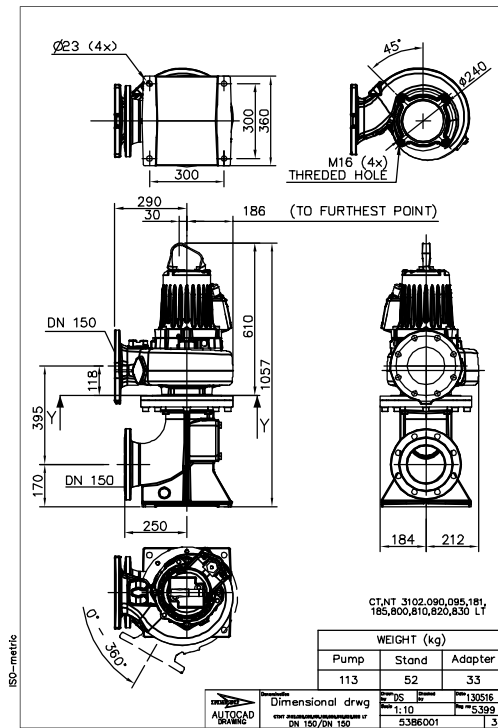

Figure 7: LT, T-installation

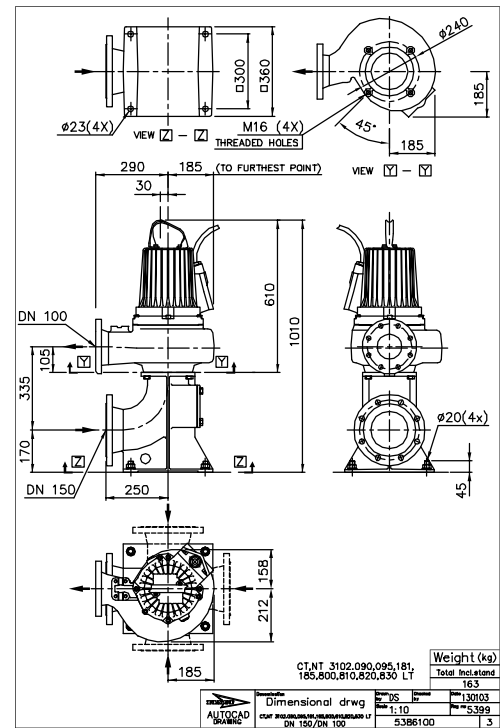

Figure 8: LT, T-installation

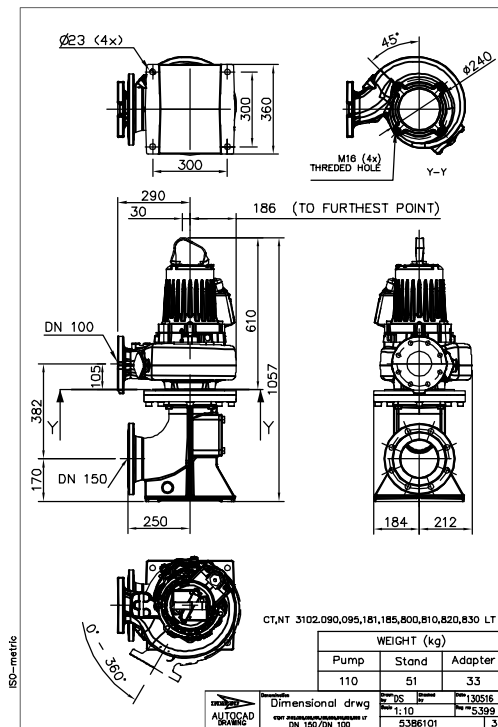

Figure 9: LT, T-installation

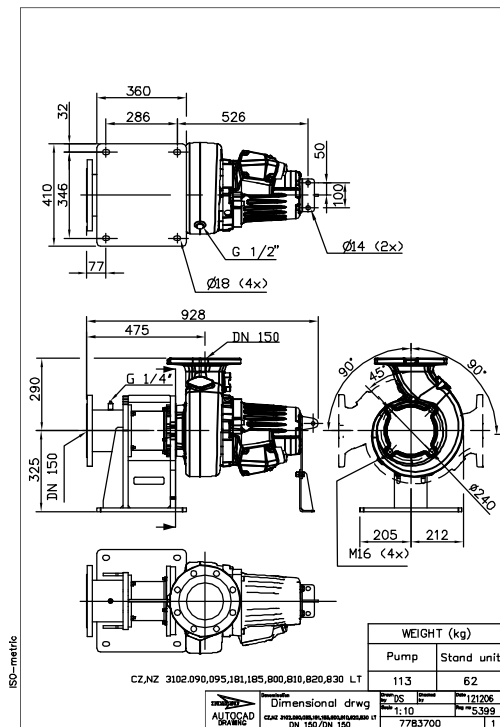

Figure 10: LT, Z-installation

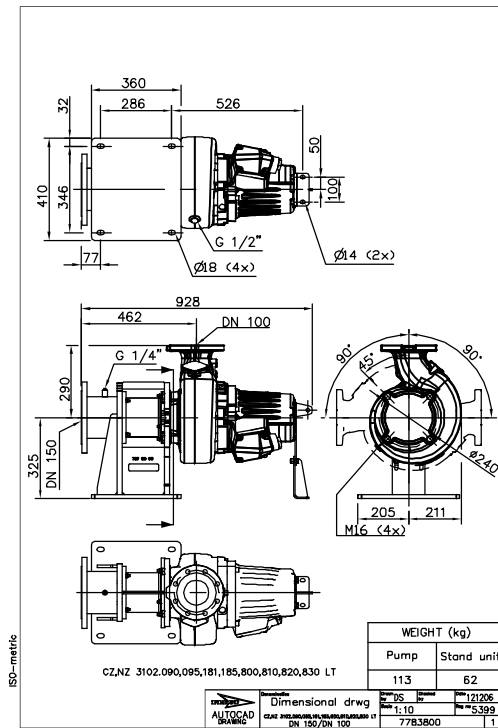

Figure 11: LT, Z-installation

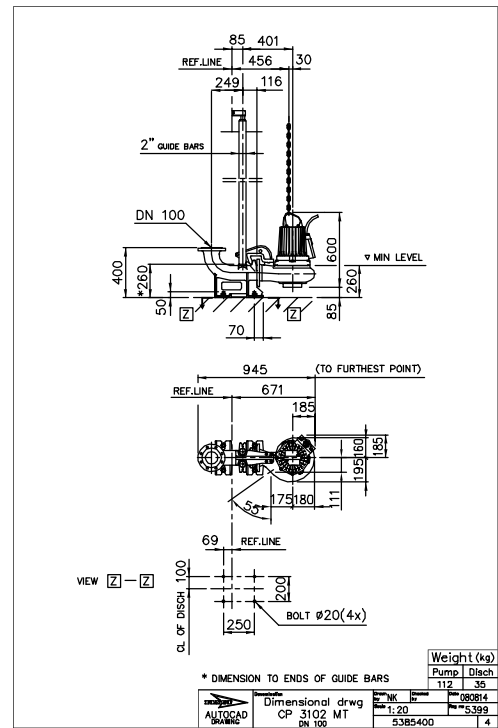

Figure 12: MT, P-installation

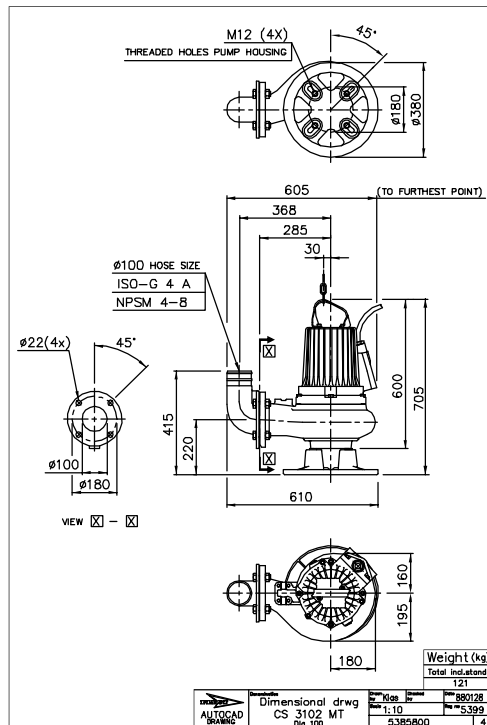

Figure 13: MT, S-installation

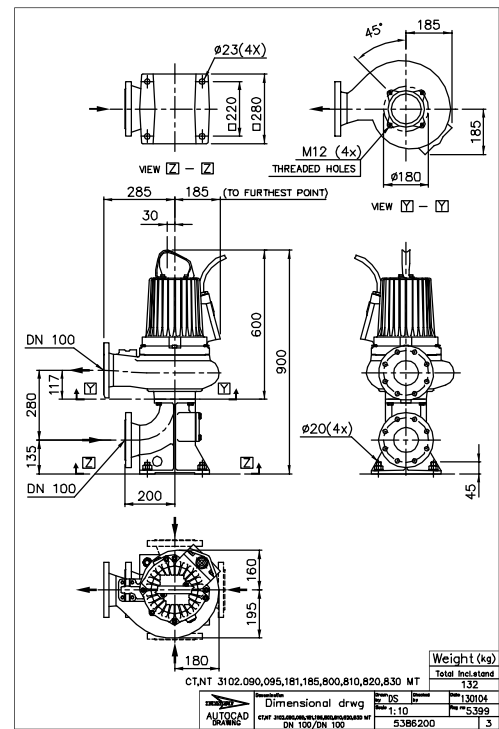

Figure 14: MT, T-installation

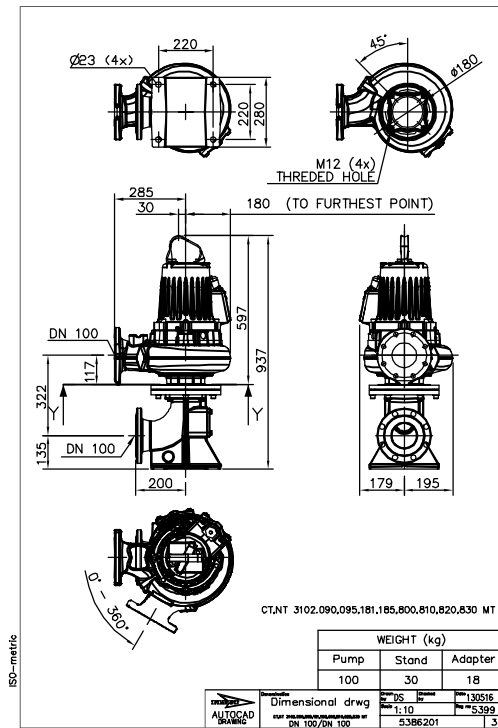

Figure 15: MT, T-installation

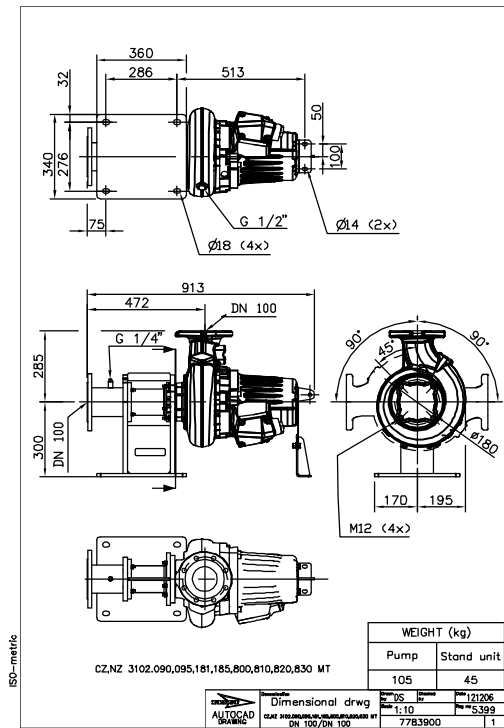

Figure 16: MT, Z-installation

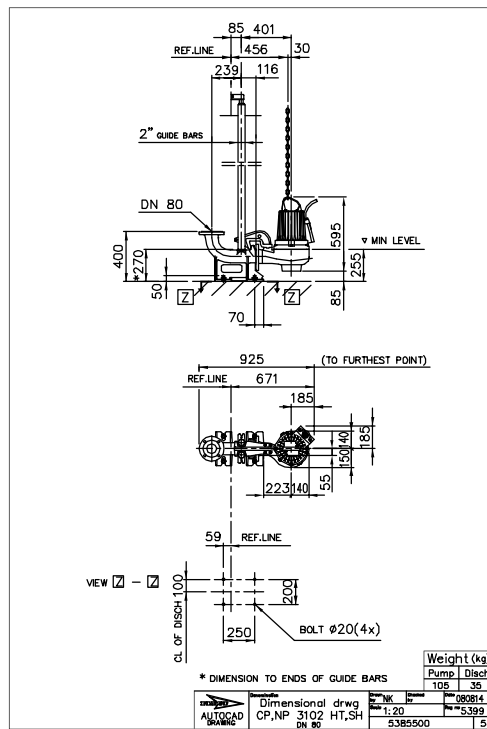

Figure 17: HT/SH, P-installation

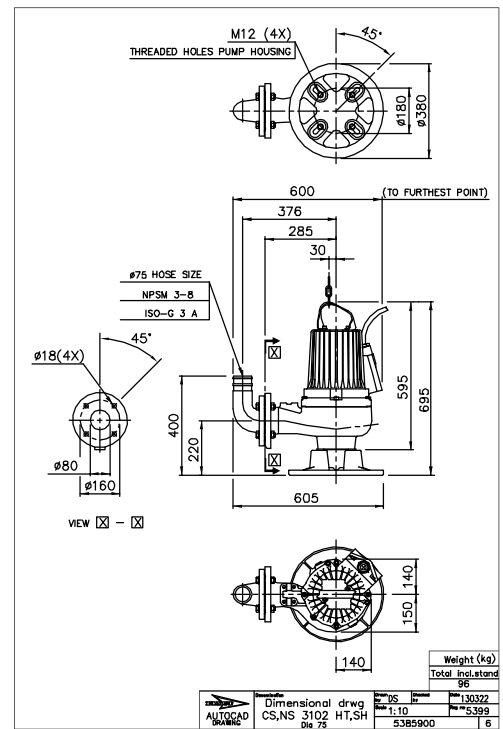

Figure 18: HT/SH, S-installation

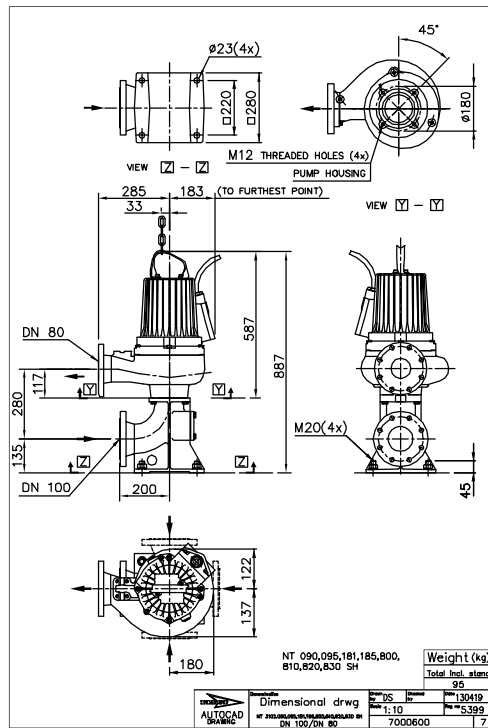

Figure 19: HT/SH, T-installation

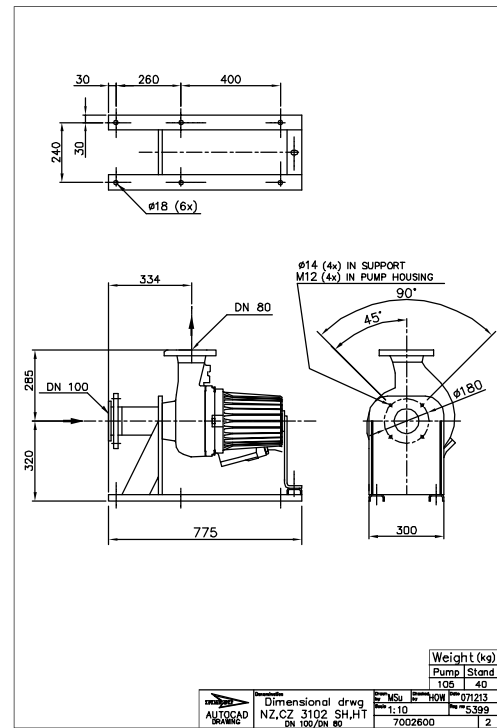

Figure 20: HT/SH, Z-installation

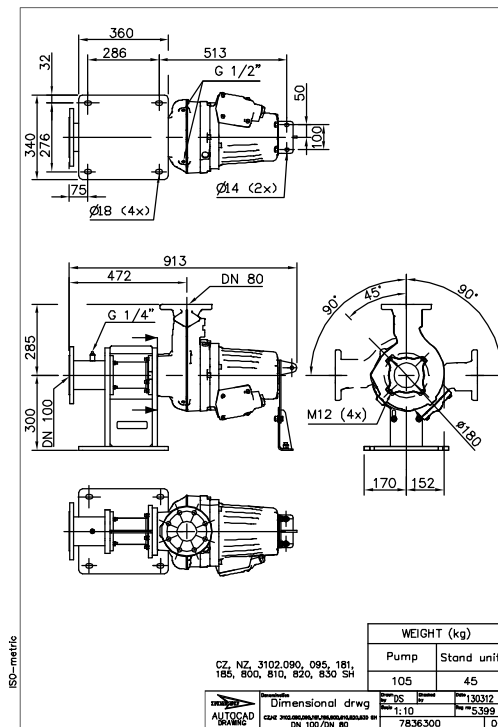

Figure 21: SH, Z-installation

Dimensions and Weight, D-pump

Drawings

All drawings are available as Acrobat documents (.pdf) and AutoCad drawings (.dwg). Contact your local sales and service representative for more information.

All dimensions are in mm.

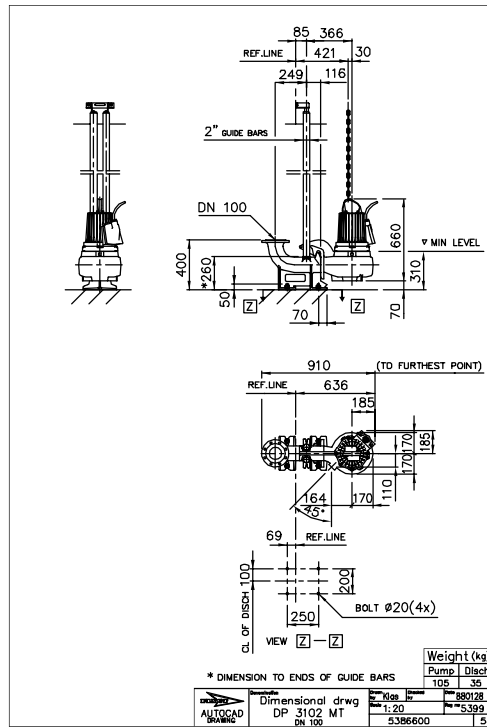

Figure 22: MT, P-installation

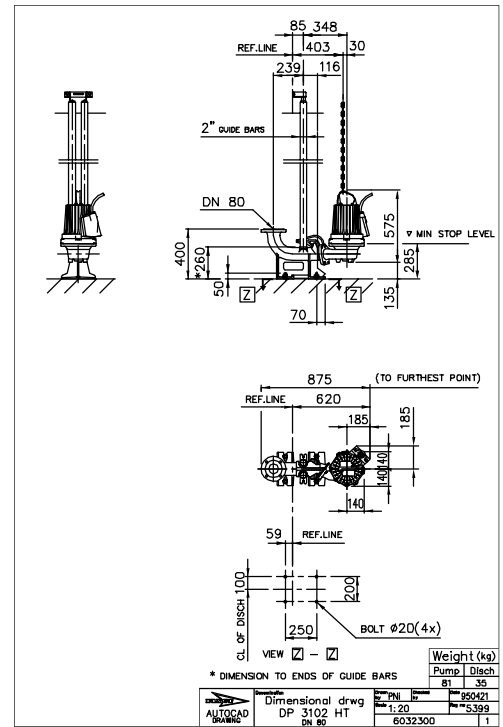

Figure 23: HT, P-installation

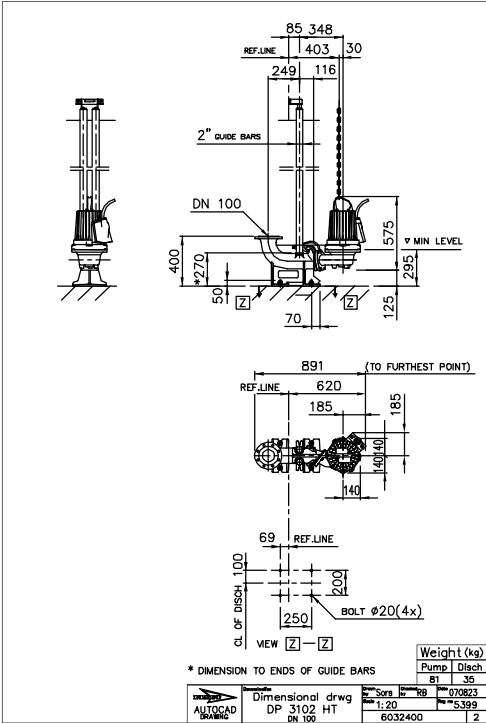

Figure 24: HT, P-installation

Dimensions and Weight, F-pump

Drawings

All drawings are available as Acrobat documents (.pdf) and AutoCad drawings (.dwg). Contact your local sales and service representative for more information.

All dimensions are in mm.

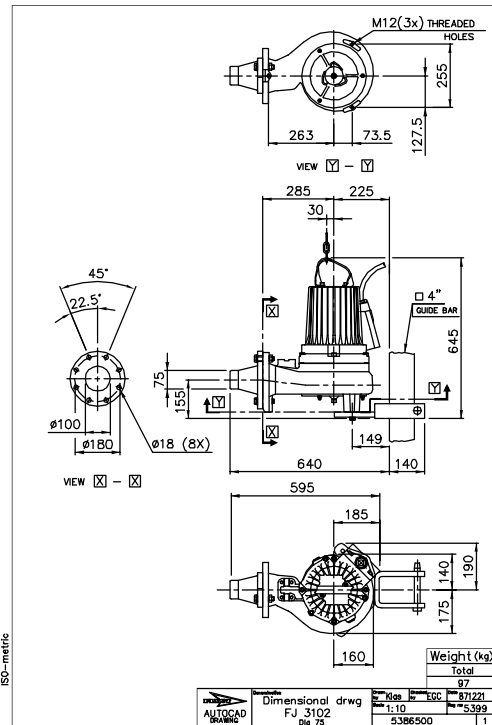

Figure 25: J-installation

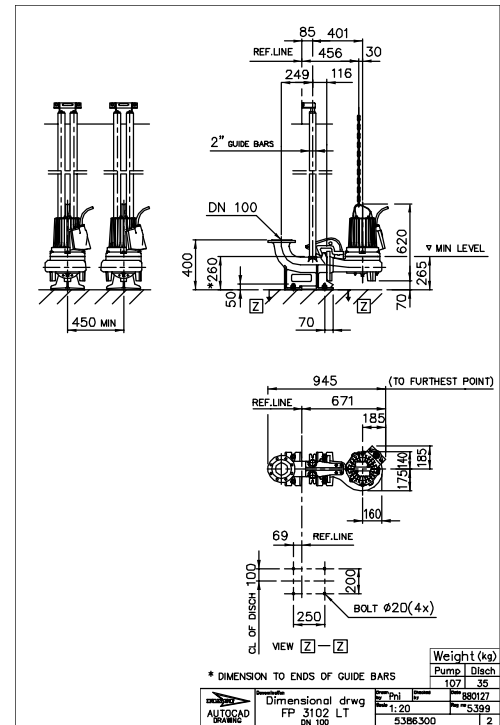

Figure 26: LT, P-installation

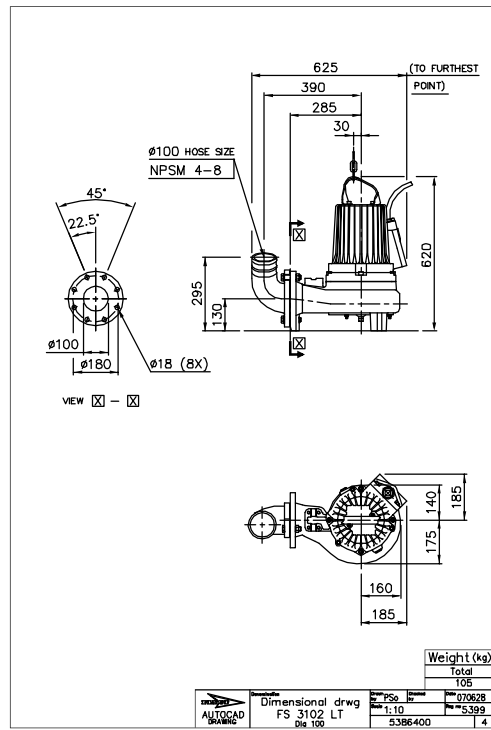

Figure 27: LT, S-installation

Dimensions and Weight, M-pump

Drawings

All drawings are available as Acrobat documents (.pdf) and AutoCad drawings (.dwg). Contact your local sales and service representative for more information.

All dimensions are in mm.

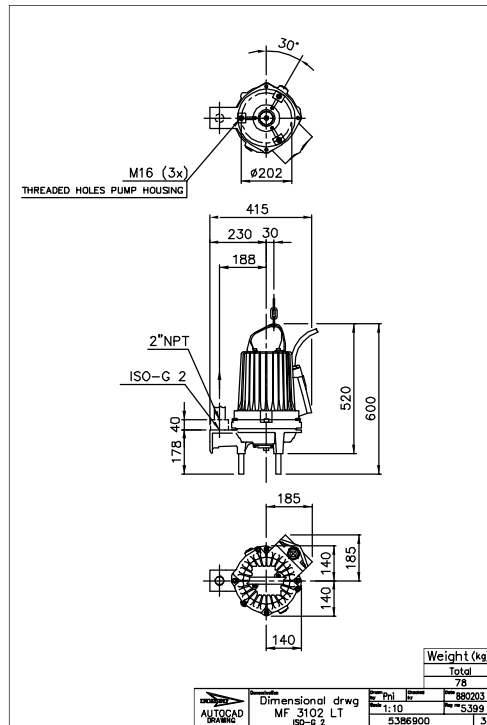

Figure 28: LT, F-installation

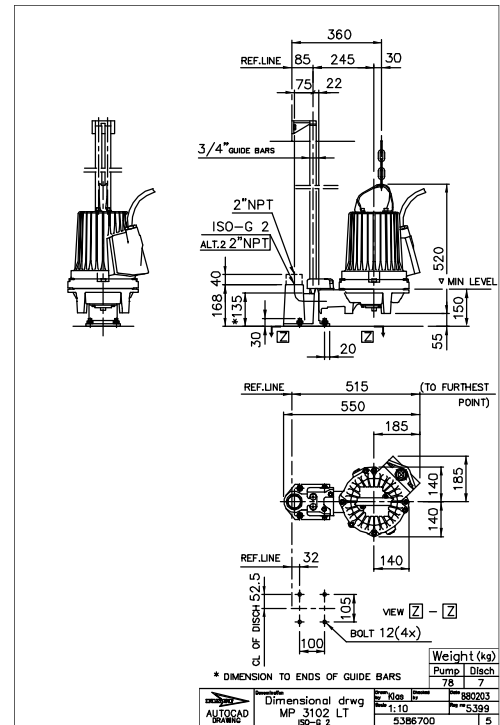

Figure 29: LT, P-installation

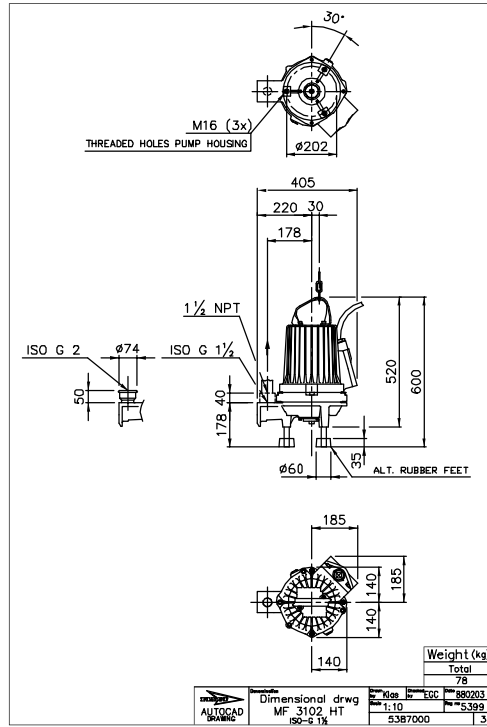

Figure 30: HT, F-installation

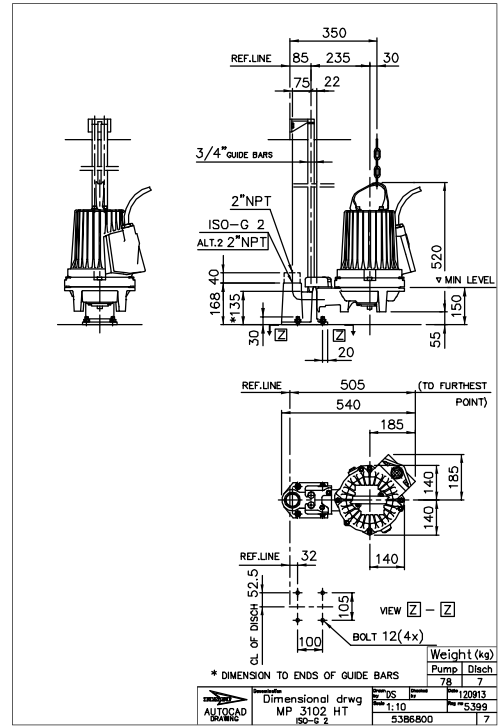

Figure 31: HT, P-installation

Dimensions and Weight, N-pump

Drawings

All drawings are available as Acrobat documents (.pdf) and AutoCad drawings (.dwg). Contact your local sales and service representative for more information.

All dimensions are in mm.

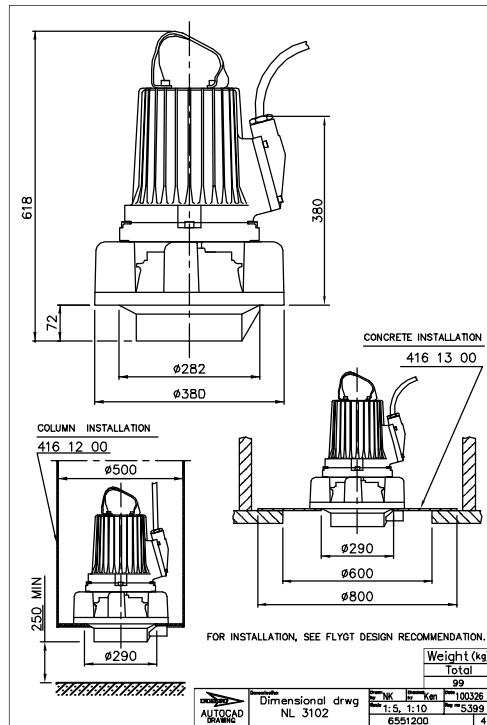

Figure 32: L-installation

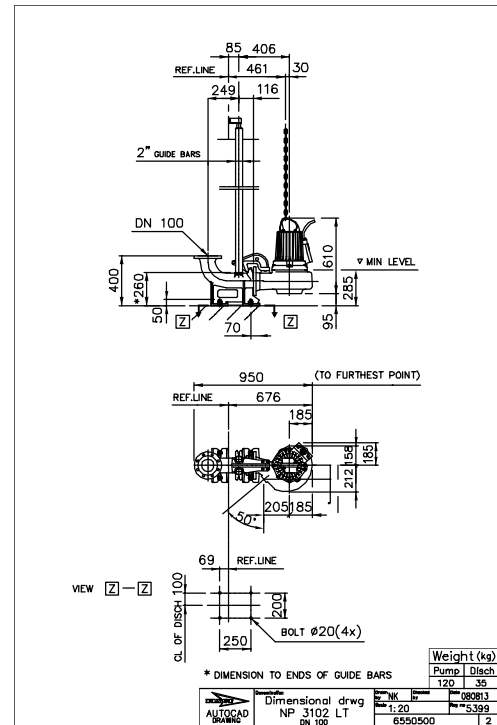

Figure 33: LT, P-installation

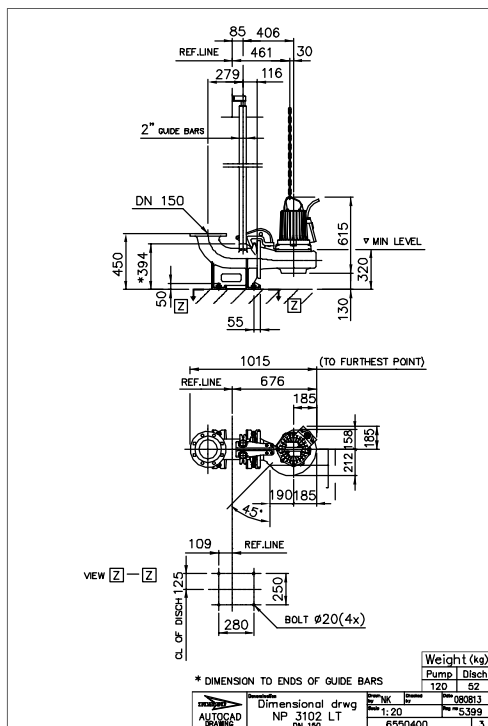

Figure 34: LT, P-installation

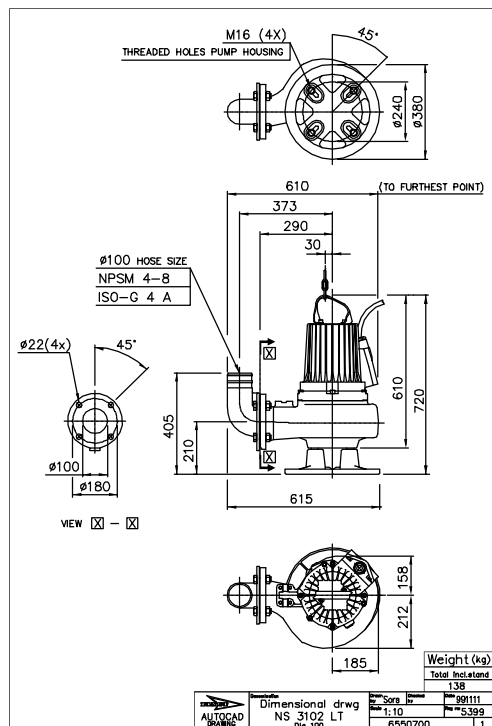

Figure 35: LT, S-installation

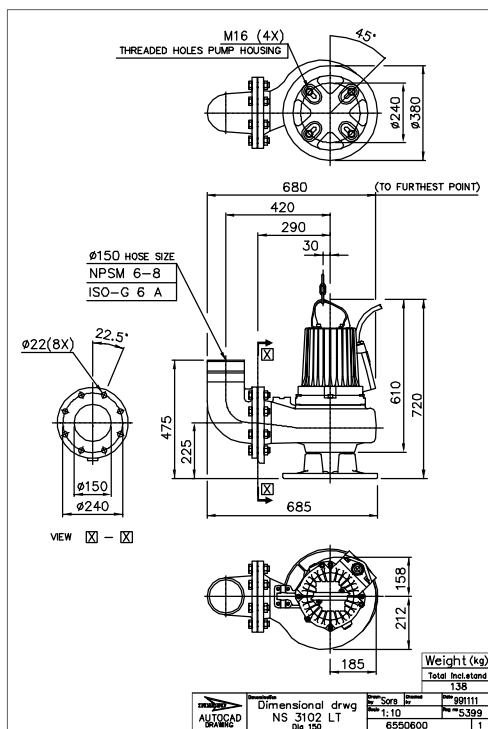

Figure 36: LT, S-installation

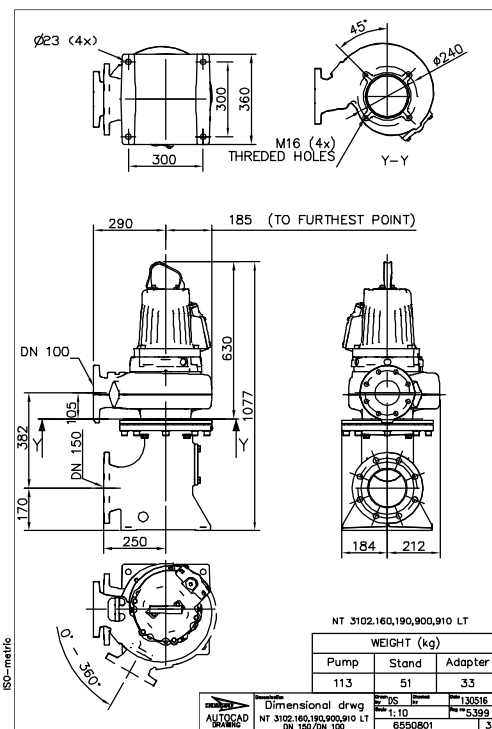

Figure 37: LT, T-installation

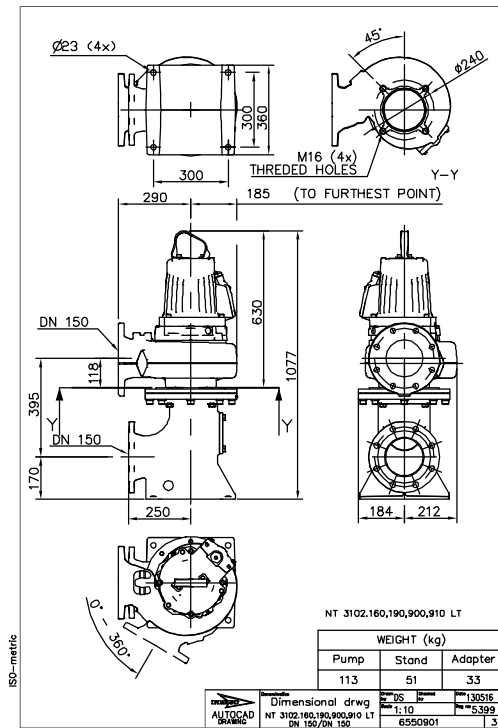

Figure 38: LT, T-installation

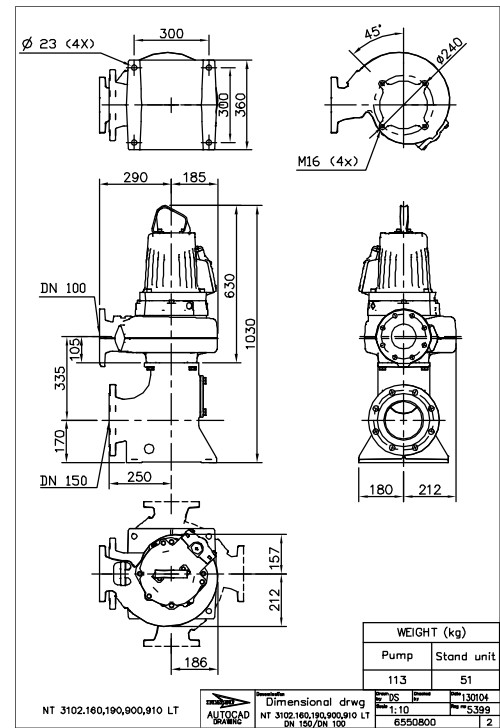

Figure 39: LT, T-installation

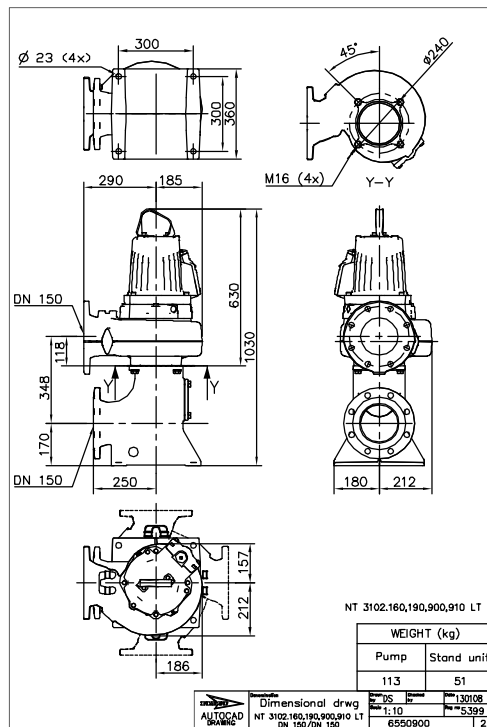

Figure 40: LT, T-installation

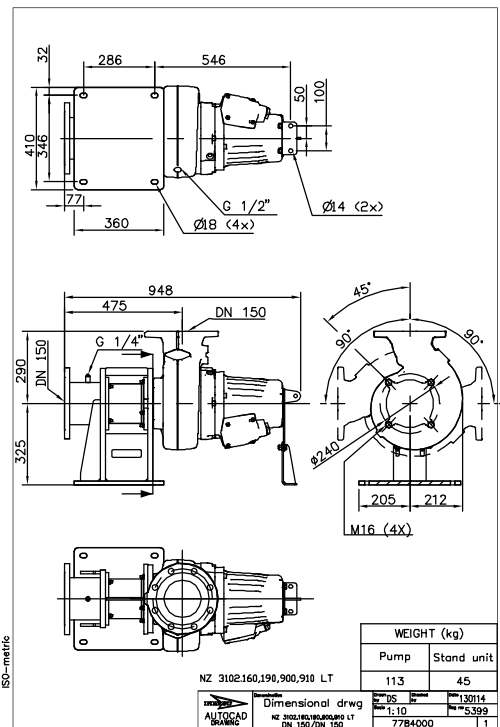

Figure 41: LT, Z-installation

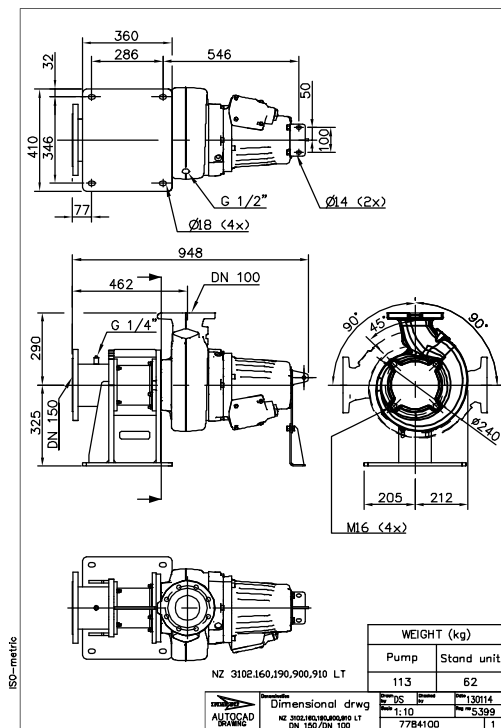

Figure 42: LT, Z-installation

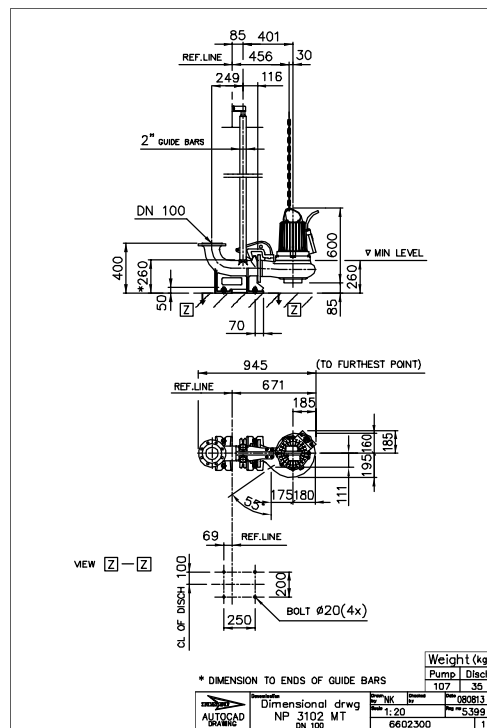

Figure 43: MT, P-installation

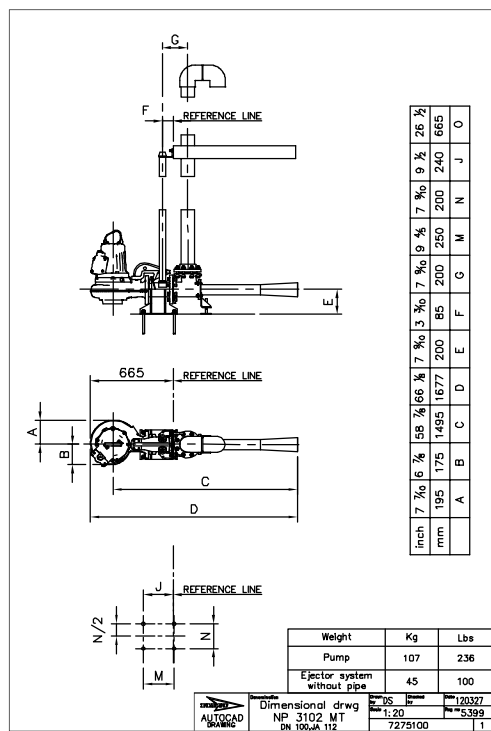

Figure 44: MT, P-installation

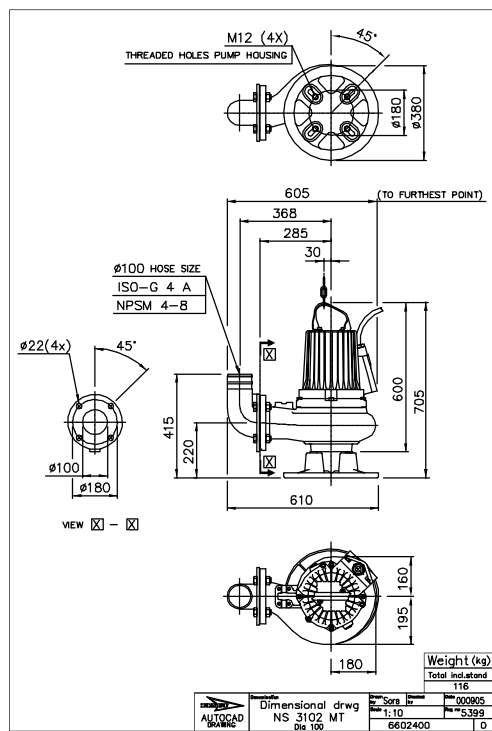

Figure 45: MT, S-installation

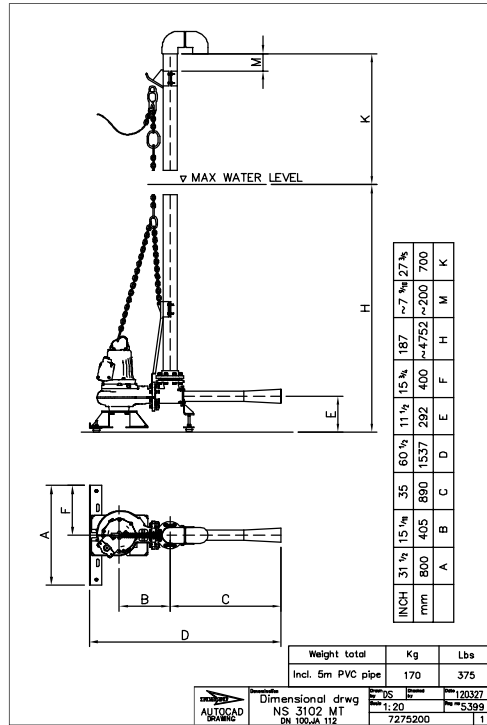

Figure 46: MT, S-installation

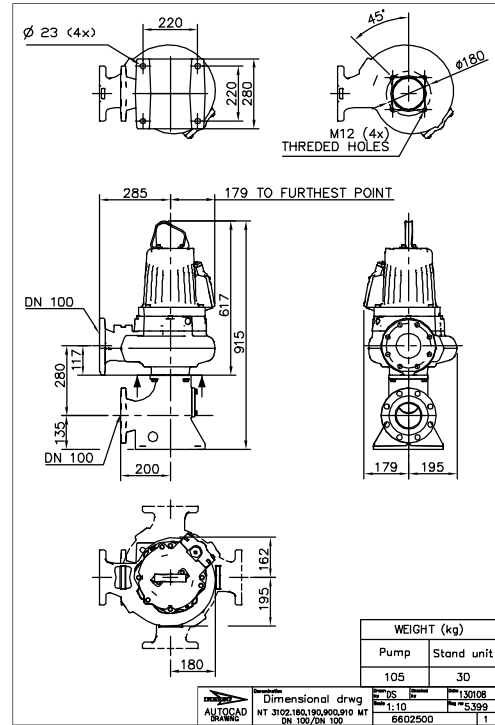

Figure 47: MT, T-installation

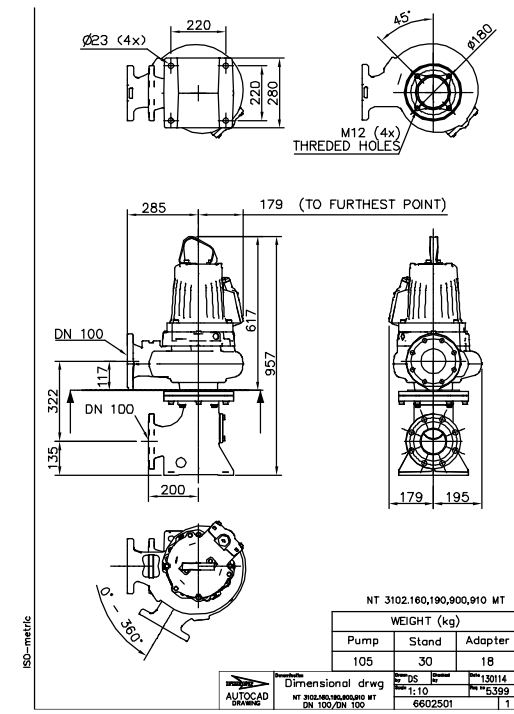

Figure 48: MT, T-installation

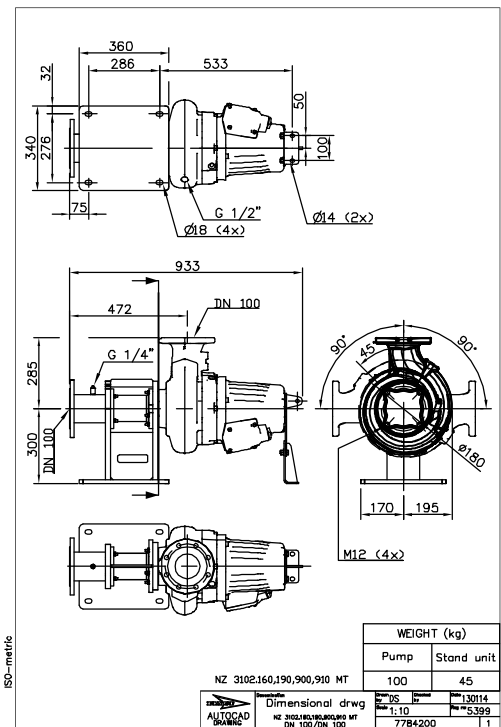

Figure 49: MT, Z-installation

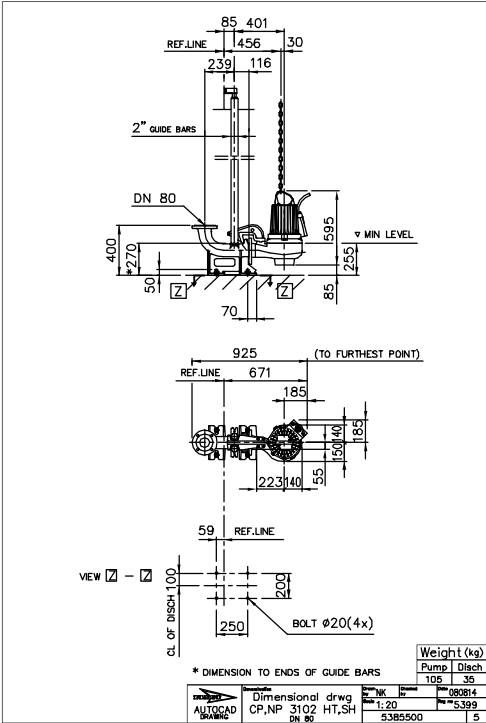

Figure 50: HT/SH, P-installation

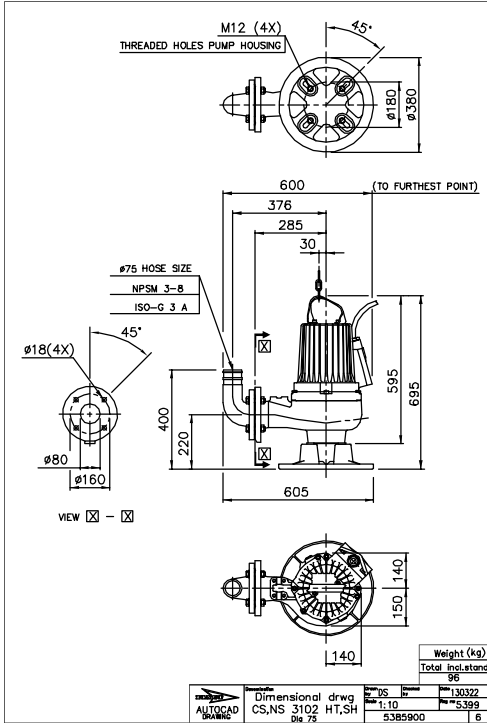

Figure 51: HT/SH, S-installation

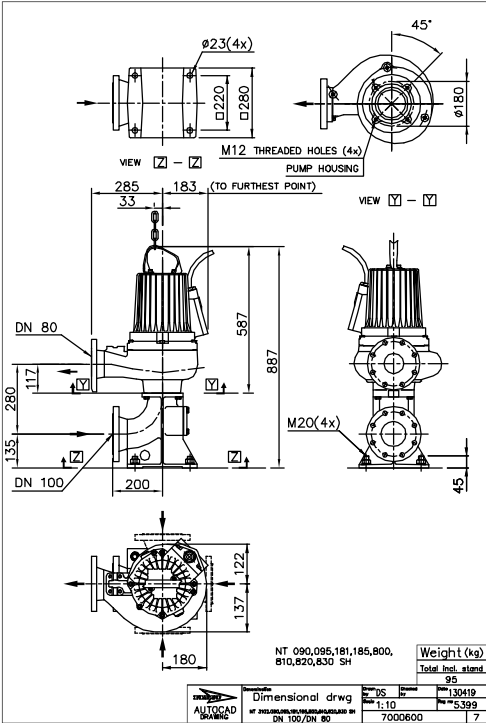

Figure 52: HT/SH, T-installation

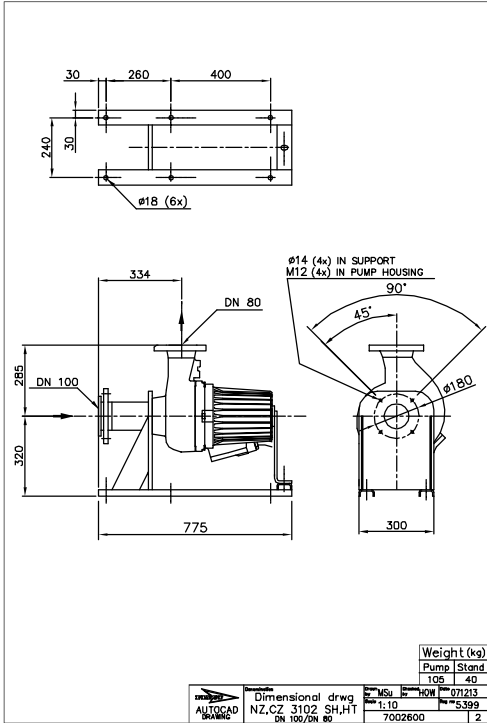

Figure 53: HT/SH, Z-installation

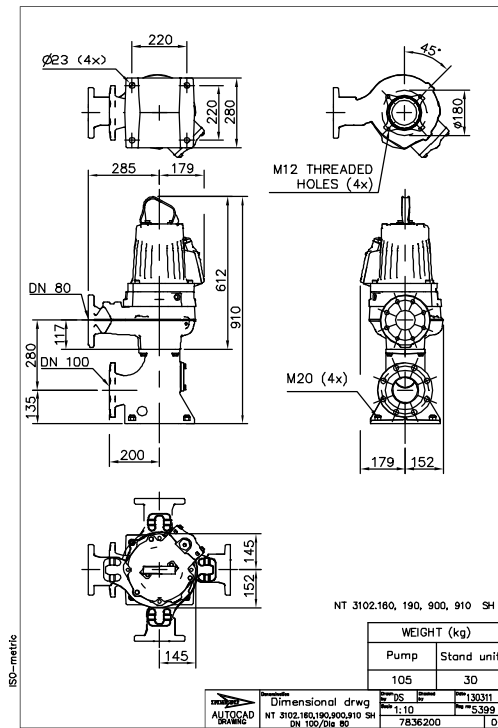

Figure 54: SH, T-installation

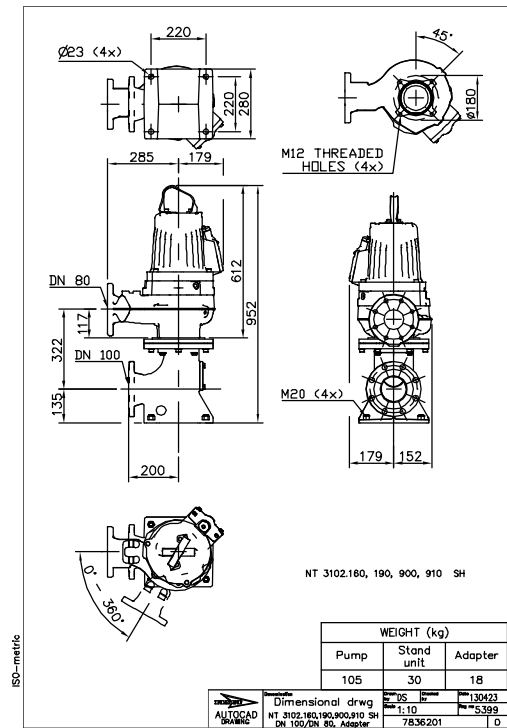

Figure 55: SH, T-installation

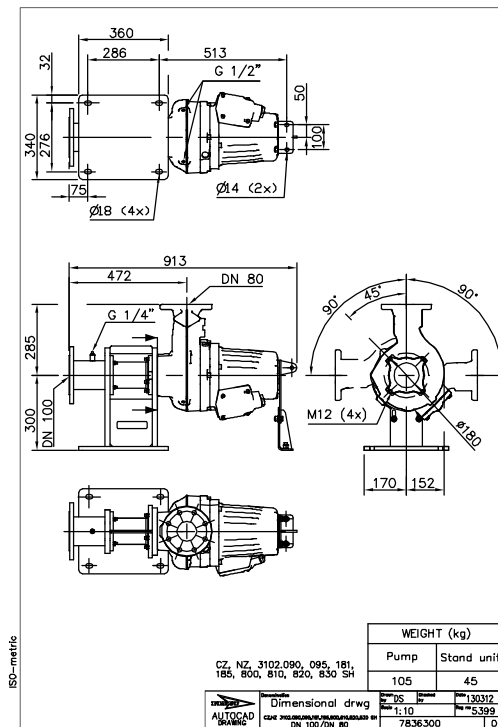

Figure 56: SH, Z-installation

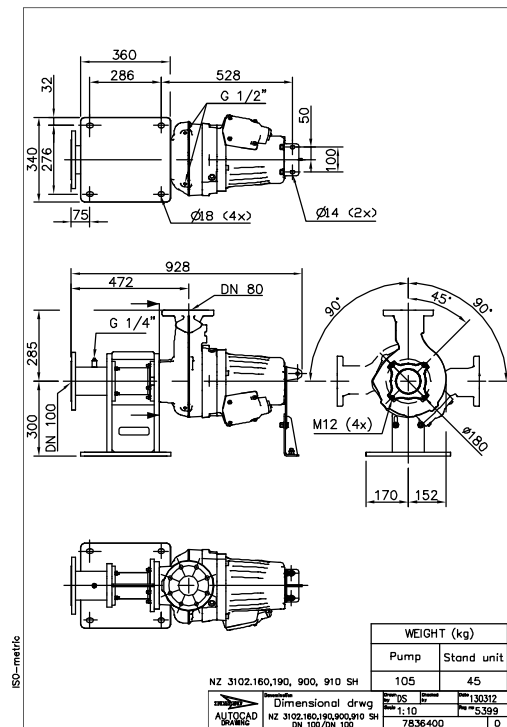

Figure 57: SH, Z-installation

Xylem |'zīləm|

- 1) The tissue in plants that brings water upward from the roots
- 2) A leading global water technology company

We're 12,900 people unified in a common purpose: creating innovative solutions to meet our world's water needs. Developing new technologies that will improve the way water is used, conserved, and re-used in the future is central to our work. We move, treat, analyze, and return water to the environment, and we help people use water efficiently, in their homes, buildings, factories and farms. In more than 150 countries, we have strong, long-standing relationships with customers who know us for our powerful combination of leading product brands and applications expertise, backed by a legacy of innovation.

For more information on how Xylem can help you, go to xyleminc.com



Xylem Water Solutions
Manufacturing AB
361 80 Emmaboda
Sweden
Tel: +46-471-24 70 00
Fax: +46-471-24 47 01
<http://tpi.xyleminc.com>

Visit our Web site for the latest version of this document and more information

The original instruction is in English. All non-English instructions are translations of the original instruction.

© 2012 Xylem Inc