



Flygt 3085, 50Hz

Table of Contents

C-pump, Standard Motor	3
Product description.....	3
Motor rating and performance curves.....	5
C-pump, Premium Efficiency Motor (IE3)	8
Product description.....	8
Motor rating and performance curves.....	10
D-pump	12
Product description.....	12
Motor rating and performance curves.....	14
F-pump	17
Product description.....	17
Motor rating and performance curves.....	19
G-pump	21
Product description.....	21
Motor rating and performance curves.....	23
M-pump	25
Product description.....	25
Motor rating and performance curves.....	27
N-pump, Standard Motor	29
Product description.....	29
Motor rating and performance curves 3085.183/.092.....	32
Motor rating and performance curves 3085.160/.190.....	34
Motor rating and performance curves 3085.760/.770.....	37
N-pump, Premium Efficiency Motor (IE3)	40
Product description.....	40
Motor rating and performance curves 3085.800/.810/.820/.830/.900/.910.....	43
Motor rating and performance curves 3085.960/.970.....	43
Dimensions and Weight, C-pump	45
Drawings.....	45
Dimensions and Weight, D-pump	50
Drawings.....	50
Dimensions and Weight, F-pump	52
Drawings.....	52
Dimensions and Weight, G-pump	54
Drawings.....	54

Dimensions and Weight, M-pump.....	55
Drawings.....	55
Dimensions and Weight, N-pump.....	57
Drawings.....	57

C-pump, Standard Motor

Product description



Usage

A submersible pump for wastewater containing solids or fibered material, clean water, or surface water.

Denomination

Type	Non-explosion proof version	Explosion proof version	Pressure class	Installation types
Cast iron	3085.183	3085.092	MT – Medium head	F, P, S, T, Z

The pump can be used in the following installations:

- F Free standing semi permanent, wet well arrangement where the pump is placed on a firm surface.
- P Semi permanent, wet well arrangement with pump installed on two guide bars with automatic connection to discharge.
- S Portable semi permanent, wet well arrangement with hose coupling or flange for connection to discharge pipeline.
- T Vertical permanent, dry well arrangement with flange connection to suction and discharge piping.
- Z Horizontal permanent, dry well arrangement with flange connection to suction and discharge piping.

Application limits

Feature	Description
Liquid temperature	Maximum 40°C (104°F)
Liquid temperature, warm water version	Maximum 70°C (158°F)
Depth of immersion	Maximum 20 m (65 ft)
pH of the pumped liquid	5.5 - 14
Liquid density	Maximum 1100 kg/m ³

Motor data

Feature	Description
Motor type	Squirrel-cage induction motor
Frequency	50 Hz
Power supply	1-phase or 3-phase
Starting method	<ul style="list-style-type: none"> • Direct on-line • Star-delta • Soft starter • Variable Frequency Drive (VFD)
Number of starts per hour	Maximum 30
Code compliance	IEC 60034-1
Voltage variation	<ul style="list-style-type: none"> • Continuously running: Maximum $\pm 5\%$ • Intermittent running: Maximum $\pm 10\%$
Voltage imbalance between phases	Maximum 2%
Stator insulation class	H (180°C, 356°F)

Cables

Application	Type
Direct-on-line start or Y/D start with two cables	Flygt SUBCAB® - a heavy duty 4 cores motor power cable with two twisted pair screened control cores. Conductor insulation rating of 90°C, which allows for increased current. Superior mechanical strength and high abrasion and tear resistant. Chemical resistant within pH 3-10 and ozone, oil, and flame resistant. Used up to 70°C water temperature. Cables < 10 mm ² with unscreened control cores.
Y/D start	Flygt SUBCAB® - a heavy duty 7 cores motor power cable with two twisted pair screened control cores. Conductor insulation rating of 90°C, which allows for increased current. Superior mechanical strength and high abrasion and tear resistant. Chemical resistant within pH 3-10 and ozone, oil, and flame resistant. Used up to 70°C water temperature. Cables < 7G6 mm ² with unscreened control cores.
Variable Frequency drive	Screened Flygt SUBCAB® - a heavy duty 4 screened cores motor power cable with four twisted pair screened control cores. Conductor insulation rating of 90°C, which allows for increased current. Superior mechanical strength and high abrasion and tear resistant. Chemical resistant within pH 3-10 and ozone, oil, and flame resistant. Used up to 70°C water temperature.

Monitoring equipment

Thermal contacts opening temperature 125° C (257° F)

Materials

Table 1: Major parts except mechanical seals

Denomination	Material	ASTM	EN
Major castings	Cast iron, gray	35B	GJL-250
Pump housing	Cast iron, gray	35B	GJL-250
Impeller, alternative 1	Cast iron, gray	35B	GJL-250

Denomination	Material	ASTM	EN
Impeller, alternative 2	Cast iron, gray	30B	GJL-200
Wear ring	Bronze	C924	CC491K; CC492K
Lifting handle	Stainless steel	AISI 316L	1.4404, 1.4432, ...
Shaft	Stainless steel	AISI 431	1.4057+QT800
Screws and nuts	Stainless steel, A4	AISI 316L, 316, 316Ti	1.4401, 1.4404, ...
O-rings, alternative 1	Nitrile rubber (NBR) 70° IRH	-	-
O-rings, alternative 2	Fluorinated rubber (FPM) 70° IRH	-	-
Oil, part no 901752	Medical white oil of paraffin type. Fulfills FDA 172.878 (a)	-	-

Table 2: Mechanical seals

Alternative	Inner seal	Outer seal
1	Carbon/ Aluminum oxide	Corrosion resistant cemented carbide/ Corrosion resistant cemented carbide
2	Carbon/ Aluminum oxide	Silicon carbide/ Silicon carbide
3	Corrosion resistant cemented carbide/ Corrosion resistant cemented carbide	Corrosion resistant cemented carbide/ Corrosion resistant cemented carbide

Surface treatment

Priming	Finish
Painted with a primer, see internal standard M0700.00.0002	Navy gray color NCS 5804-B07G. Two-component high-solid top coating, see internal standard M0700.00.0004 for standard painting and M0700.00.0008 for special painting.

Options

- Warm liquid version (non-explosion proof versions)
- Leakage sensor in the stator housing (FLS)
- Leakage sensor in the oil housing (CLS)
- Surface treatment (Epoxy)
- Zinc anodes
- Other cables

Accessories

Discharge connections, adapters, hose connections, and other mechanical accessories.
Electrical accessories such as pump controller, control panels, starters, monitoring relays, cables.

Motor rating and performance curves

These are examples of motor rating and curves. For more information, please contact your local sales and service representative.

Star-delta starting current is 1/3 of Direct on-line starting current.

MT

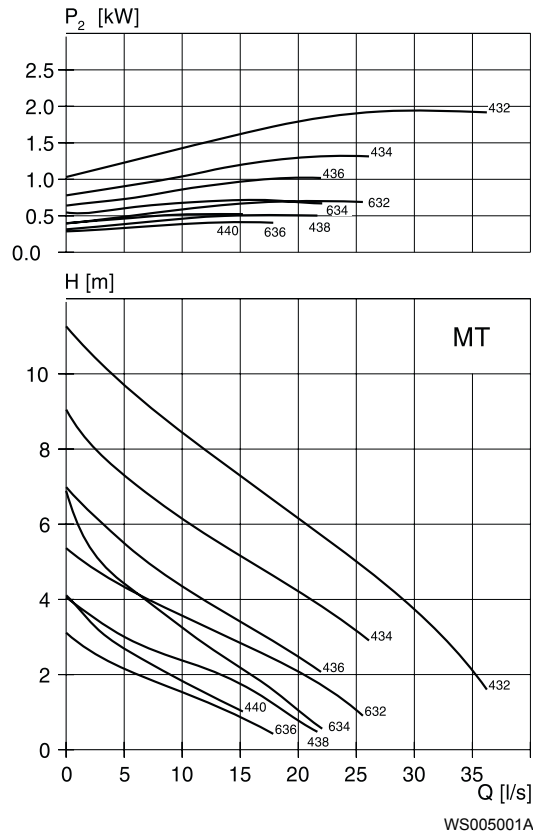

Table 3: 400 V, 50 Hz, 3-phase

Rated power, kW	Rated power, hp	Curve/Impeller No	Revolutions per minute, rpm	Rated current, A	Starting current, A	Power factor, cos φ	Installation
0,9	1,2	632	940	2,9	11	0,65	F,P,S
0,9	1,2	634	940	2,9	11	0,65	F,P,S
0,9	1,2	636	940	2,9	11	0,65	F,P,S
1	1,3	436	1455	3,2	23	0,6	T,Z
1	1,3	438	1455	3,2	23	0,6	T,Z
1	1,3	440	1455	3,2	23	0,6	T,Z
1,3	1,7	434	1440	3,6	23	0,68	F,P,S
1,3	1,7	436	1440	3,6	23	0,68	F,P,S
1,3	1,7	438	1440	3,6	23	0,68	F,P,S
1,3	1,7	440	1440	3,6	23	0,68	F,P,S
1,4	1,9	434	1435	3,7	23	0,7	T,Z
1,4	1,9	436	1435	3,7	23	0,7	T,Z
1,4	1,9	438	1435	3,7	23	0,7	T,Z
1,4	1,9	440	1435	3,7	23	0,7	T,Z
2	2,7	432	1400	4,8	23	0,8	F,P,S
2	2,7	434	1400	4,8	23	0,8	F,P,S
2	2,7	436	1400	4,8	23	0,8	F,P,S
2	2,7	438	1400	4,8	23	0,8	F,P,S

Rated power, kW	Rated power, hp	Curve/Impeller No	Revolutions per minute, rpm	Rated current, A	Starting current, A	Power factor, cos ϕ	Installation
2	2,7	440	1400	4,8	23	0,8	F,P,S

Table 4: 230 V, 50 Hz, 1-phase

Rated power, kW	Rated power, hp	Curve/Impeller No	Revolutions per minute, rpm	Rated current, A	Starting current, A	Power factor, cos ϕ	Installation
0,95	1,3	436	1410	7,2	28	0,86	F,P,S
0,95	1,3	438	1410	7,2	28	0,86	F,P,S
0,95	1,3	440	1410	7,2	28	0,86	F,P,S
1,5	2	434	1425	9,4	43	0,9	F,P,S
1,5	2	436	1425	9,4	43	0,9	F,P,S
1,5	2	438	1425	9,4	43	0,9	F,P,S
1,5	2	440	1425	9,4	43	0,9	F,P,S

C-pump, Premium Efficiency Motor (IE3)

Product description



Usage

A submersible pump for wastewater containing solids or fibered material, clean water, or surface water.

Denomination

Type	Non-explosion proof version	Explosion proof version	Pressure class	Installation types
Cast iron	3085.800	3085.810	MT – Medium head	F, P, S, T, Z

The pump can be used in the following installations:

- F Free standing semi permanent, wet well arrangement where the pump is placed on a firm surface.
- P Semi permanent, wet well arrangement with pump installed on two guide bars with automatic connection to discharge.
- S Portable semi permanent, wet well arrangement with hose coupling or flange for connection to discharge pipeline.
- T Vertical permanent, dry well arrangement with flange connection to suction and discharge piping.
- Z Horizontal permanent, dry well arrangement with flange connection to suction and discharge piping.

Application limits

Feature	Description
Liquid temperature	Maximum 40°C (104°F)
Depth of immersion	Maximum 20 m (65 ft)
pH of the pumped liquid	5.5 - 14
Liquid density	Maximum 1100 kg/m ³

Motor data

Feature	Description
Motor type	Line started permanent magnet motor (LSPM)
Frequency	50 Hz
Power supply	1-phase or 3-phase
Starting method	<ul style="list-style-type: none"> • Direct on-line • Star-delta • Soft starter • Variable Frequency Drive (VFD)
Number of starts per hour	Maximum 30
Code compliance	IEC 60034-1
Voltage variation	<ul style="list-style-type: none"> • Continuously running: Maximum $\pm 5\%$ • Intermittent running: Maximum $\pm 10\%$
Voltage imbalance between phases	Maximum 2%
Stator insulation class	H (180°C, 356°F)

Cables

Application	Type
Direct-on-line start or Y/D start with two cables	Flygt SUBCAB® - a heavy duty 4 cores motor power cable with two twisted pair screened control cores. Conductor insulation rating of 90°C, which allows for increased current. Superior mechanical strength and high abrasion and tear resistant. Chemical resistant within pH 3-10 and ozone, oil, and flame resistant. Used up to 70°C water temperature. Cables < 10 mm ² with unscreened control cores.
Y/D start	Flygt SUBCAB® - a heavy duty 7 cores motor power cable with two twisted pair screened control cores. Conductor insulation rating of 90°C, which allows for increased current. Superior mechanical strength and high abrasion and tear resistant. Chemical resistant within pH 3-10 and ozone, oil, and flame resistant. Used up to 70°C water temperature. Cables < 7G6 mm ² with unscreened control cores.
Variable Frequency drive	Screened Flygt SUBCAB® - a heavy duty 4 screened cores motor power cable with four twisted pair screened control cores. Conductor insulation rating of 90°C, which allows for increased current. Superior mechanical strength and high abrasion and tear resistant. Chemical resistant within pH 3-10 and ozone, oil, and flame resistant. Used up to 70°C water temperature.

Monitoring equipment

Thermal contacts opening temperature 125° C (257° F)

Materials

Table 5: Major parts except mechanical seals

Denomination	Material	ASTM	EN
Major castings	Cast iron, gray	35B	GJL-250
Pump housing	Cast iron, gray	35B	GJL-250
Impeller, alternative 1	Cast iron, gray	35B	GJL-250

Denomination	Material	ASTM	EN
Impeller, alternative 2	Cast iron, gray	30B	GJL-200
Wear ring	Bronze	C924	CC491K; CC492K
Lifting handle	Stainless steel	AISI 316L	1.4404, 1.4432, ...
Shaft	Stainless steel	AISI 431	1.4057+QT800
Screws and nuts	Stainless steel, A4	AISI 316L, 316, 316Ti	1.4401, 1.4404, ...
O-rings, alternative 1	Nitrile rubber (NBR) 70° IRH	-	-
O-rings, alternative 2	Fluorinated rubber (FPM) 70° IRH	-	-
Oil, part no 901752	Medical white oil of paraffin type. Fulfills FDA 172.878 (a)	-	-

Table 6: Mechanical seals

Alternative	Inner seal	Outer seal
1	Carbon/ Aluminum oxide	Corrosion resistant cemented carbide/ Corrosion resistant cemented carbide
2	Carbon/ Aluminum oxide	Silicon carbide/ Silicon carbide
3	Corrosion resistant cemented carbide/ Corrosion resistant cemented carbide	Corrosion resistant cemented carbide/ Corrosion resistant cemented carbide

Surface treatment

Priming	Finish
Painted with a primer, see internal standard M0700.00.0002	Navy gray color NCS 5804-B07G. Two-component high-solid top coating, see internal standard M0700.00.0004 for standard painting and M0700.00.0008 for special painting.

Options

- Leakage sensor in the stator housing (FLS)
- Leakage sensor in the oil housing (CLS)
- Surface treatment (Epoxy)
- Zinc anodes
- Other cables

Accessories

Discharge connections, adapters, hose connections, and other mechanical accessories. Electrical accessories such as pump controller, control panels, starters, monitoring relays, cables.

Motor rating and performance curves

These are examples of motor rating and curves. For more information, please contact your local sales and service representative.

Star-delta starting current is 1/3 of Direct on-line starting current.

MT

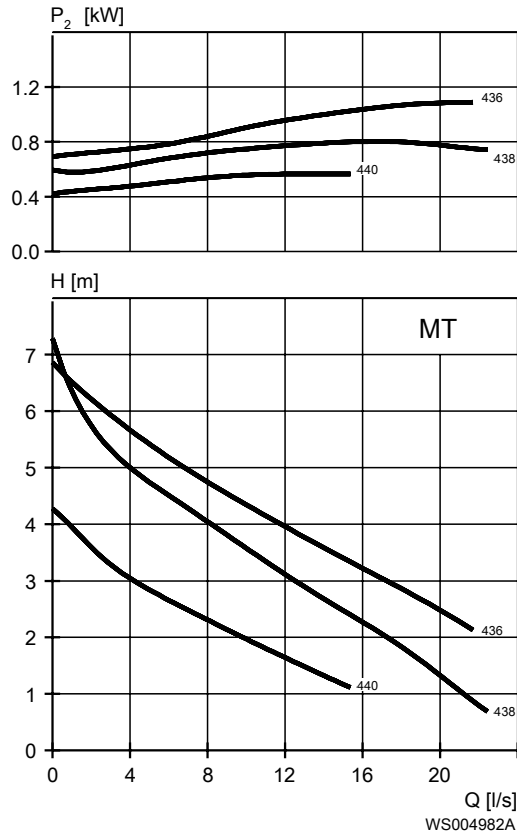

Table 7: 400 V, 50 Hz, 3-phase

Rated power, kW	Rated power, hp	Curve/ Impeller No	Revolutions per minute, rpm	Rated Current, A	Start current, A	Power factor, cos φ	Installation
1.6	2.1	436	1500	3.3	23	0.82	F,P,S,T,Z
1.6	2.1	438	1500	3.3	23	0.82	F,P,S,T,Z
1.6	2.1	440	1500	3.3	23	0.82	F,P,S,T,Z
2	2.7	436	1500	3.8	23	0.87	F,P,S,T,Z
2	2.7	438	1500	3.8	23	0.87	F,P,S,T,Z
2	2.7	440	1500	3.8	23	0.87	F,P,S,T,Z

D-pump

Product description



Usage

A submersible pump, with vortex hydraulic, for liquids containing solids and abrasive media, or light wastewater.

Denomination

Type	Non-explosion proof version	Explosion proof version	Pressure class	Installation types
Cast iron	3085.183	3085.092	<ul style="list-style-type: none"> • MT – Medium head • HT – High head 	P, S

The pump can be used in the following installations:

- P Semi permanent, wet well arrangement with pump installed on two guide bars with automatic connection to discharge.
- S Portable semi permanent, wet well arrangement with hose coupling or flange for connection to discharge pipeline.

Application limits

Feature	Description
Liquid temperature	Maximum 40°C (104°F)
Liquid temperature, warm water version	Maximum 70°C (158°F)
Depth of immersion	Maximum 20 m (65 ft)
pH of the pumped liquid	5.5 - 14
Liquid density	Maximum 1100 kg/m ³

Motor data

Feature	Description
Motor type	Squirrel-cage induction motor
Frequency	50 Hz
Power supply	1-phase or 3-phase

Feature	Description
Starting method	<ul style="list-style-type: none"> • Direct on-line • Star-delta • Soft starter • Variable Frequency Drive (VFD)
Number of starts per hour	Maximum 30
Code compliance	IEC 60034-1
Voltage variation	<ul style="list-style-type: none"> • Continuously running: Maximum $\pm 5\%$ • Intermittent running: Maximum $\pm 10\%$
Voltage imbalance between phases	Maximum 2%
Stator insulation class	H (180°C, 356°F)

Cables

Application	Type
Direct-on-line start or Y/D start with two cables	Flygt SUBCAB® - a heavy duty 4 cores motor power cable with two twisted pair screened control cores. Conductor insulation rating of 90°C, which allows for increased current. Superior mechanical strength and high abrasion and tear resistant. Chemical resistant within pH 3-10 and ozone, oil, and flame resistant. Used up to 70°C water temperature. Cables < 10 mm ² with unscreened control cores.
Y/D start	Flygt SUBCAB® - a heavy duty 7 cores motor power cable with two twisted pair screened control cores. Conductor insulation rating of 90°C, which allows for increased current. Superior mechanical strength and high abrasion and tear resistant. Chemical resistant within pH 3-10 and ozone, oil, and flame resistant. Used up to 70°C water temperature. Cables < 7G6 mm ² with unscreened control cores.
Variable Frequency drive	Screened Flygt SUBCAB® - a heavy duty 4 screened cores motor power cable with four twisted pair screened control cores. Conductor insulation rating of 90°C, which allows for increased current. Superior mechanical strength and high abrasion and tear resistant. Chemical resistant within pH 3-10 and ozone, oil, and flame resistant. Used up to 70°C water temperature.

Monitoring equipment

Thermal contacts opening temperature 125° C (257° F)

Materials

Table 8: Major parts except mechanical seals

Denomination	Material	ASTM	EN
Major castings	Cast iron, gray	35B	GJL-250
Pump housing, alternative 1	Cast iron, gray	35B	GJL-250
Pump housing, alternative 2	Cast iron, gray, 45 HRC	35B	GJL-250
Impeller, alternative 1	Cast iron, gray	35B	GJL-250
Impeller, alternative 2	Cast iron, gray	30B	GJL-200
Impeller, alternative 3	Cast iron, gray	30B	GJL-200

Denomination	Material	ASTM	EN
Lifting handle	Stainless steel	AISI 316L	1.4404,1.4432, ...
Shaft	Stainless steel	AISI 431	1.4057+QT800
Screws and nuts	Stainless steel, A4	AISI 316L, 316, 316Ti	1.4401,1.4404, ...
O-rings, alternative 1	Nitrile rubber (NBR) 70° IRH	-	-
O-rings, alternative 2	Fluorinated rubber (FPM) 70° IRH	-	-
Oil, part no 901752	Medical white oil of paraffin type. Fulfills FDA 172.878 (a)	-	-

Table 9: Mechanical seals

Alternative	Inner seal	Outer seal
1	Carbon/ Aluminum oxide	Corrosion resistant cemented carbide/ Corrosion resistant cemented carbide
2	Carbon/ Aluminum oxide	Silicon carbide/ Silicon carbide
3	Corrosion resistant cemented carbide/ Corrosion resistant cemented carbide	Corrosion resistant cemented carbide/ Corrosion resistant cemented carbide

Surface treatment

Priming	Finish
Painted with a primer, see internal standard M0700.00.0002	Navy gray color NCS 5804-B07G. Two-component high-solid top coating, see internal standard M0700.00.0004 for standard painting and M0700.00.0008 for special painting.

Options

- Warm liquid version (non-explosion proof versions)
- Leakage sensor in the stator housing (FLS)
- Leakage sensor in the oil housing (CLS)
- Surface treatment (Epoxy)
- Other cables

Accessories

Discharge connections, adapters, hose connections, and other mechanical accessories. Electrical accessories such as pump controller, control panels, starters, monitoring relays, cables.

Motor rating and performance curves

These are examples of motor rating and curves. For more information, please contact your local sales and service representative.

Star-delta starting current is 1/3 of Direct on-line starting current.

MT

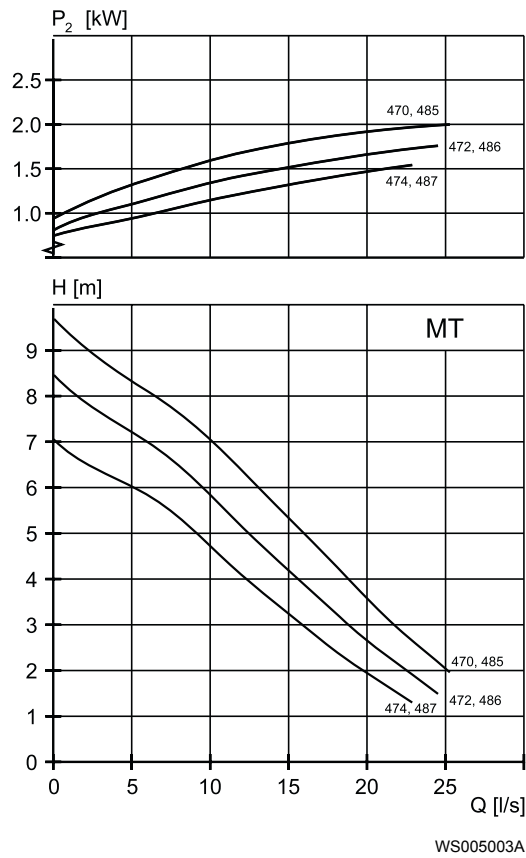

Table 10: 400 V, 50 Hz, 3-phase

Rated power, kW	Rated power, hp	Curve/ Impeller No	Revolutions per minute, rpm	Rated current, A	Starting current, A	Power factor, $\cos \varphi$	Installation
2	2,7	470	1400	4,8	23	0,8	P,S
2	2,7	472	1400	4,8	23	0,8	P,S
2	2,7	474	1400	4,8	23	0,8	P,S
2	2,7	485	1400	4,8	23	0,8	P,S
2	2,7	486	1400	4,8	23	0,8	P,S
2	2,7	487	1400	4,8	23	0,8	P,S

Table 11: 230 V, 50 Hz, 1-phase

Rated power, kW	Rated power, hp	Curve/ Impeller No	Revolutions per minute, rpm	Rated current, A	Starting current, A	Power factor, $\cos \varphi$	Installation
1,5	2	472	1425	9,4	43	0,9	P,S
1,5	2	474	1425	9,4	43	0,9	P,S
1,5	2	486	1425	9,4	43	0,9	P,S
1,5	2	487	1425	9,4	43	0,9	P,S

HT

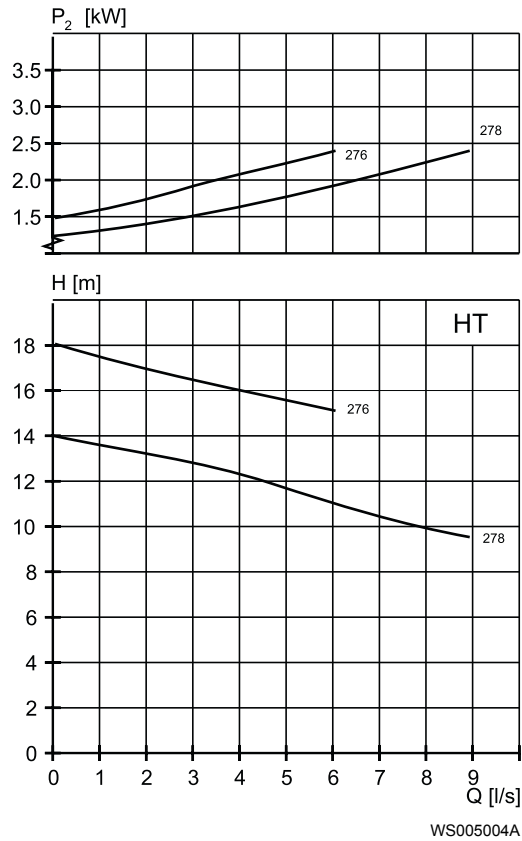

Table 12: 400 V, 50 Hz, 3-phase

Rated power, kW	Rated power, hp	Curve/ Impeller No	Revolutions per minute, rpm	Rated current, A	Starting current, A	Power factor, $\cos \varphi$	Installation
2,4	3,2	276	2845	4,8	29	0,9	P,S
2,4	3,2	278	2845	4,8	29	0,9	P,S

F-pump

Product description



Usage

A submersible pump for liquid manure, or heavily contaminated sewage and sludge. The impeller is S-shaped and has a cutting function.

Denomination

Type	Non-explosion proof version	Explosion proof version	Pressure class	Installation types
Chopper Cast iron	3085.183	3085.092	• LT – Low head	P, S

The pump can be used in the following installations:

- P Semi permanent, wet well arrangement with pump installed on two guide bars with automatic connection to discharge.
- S Portable semi permanent, wet well arrangement with hose coupling or flange for connection to discharge pipeline.

Application limits

Feature	Description
Liquid temperature	Maximum 40°C (104°F)
Liquid temperature, warm water version	Maximum 70°C (158°F)
Depth of immersion	Maximum 20 m (65 ft)
pH of the pumped liquid	5.5 - 14
Liquid density	Maximum 1100 kg/m ³

Motor data

Feature	Description
Motor type	Squirrel-cage induction motor
Frequency	50 Hz
Power supply	1-phase or 3-phase

Feature	Description
Starting method	<ul style="list-style-type: none"> • Direct on-line • Star-delta • Soft starter • Variable Frequency Drive (VFD)
Number of starts per hour	Maximum 30
Code compliance	IEC 60034-1
Voltage variation	<ul style="list-style-type: none"> • Continuously running: Maximum $\pm 5\%$ • Intermittent running: Maximum $\pm 10\%$
Voltage imbalance between phases	Maximum 2%
Stator insulation class	H (180°C, 356°F)

Cables

Application	Type
Direct-on-line start or Y/D start with two cables	Flygt SUBCAB® - a heavy duty 4 cores motor power cable with two twisted pair screened control cores. Conductor insulation rating of 90°C, which allows for increased current. Superior mechanical strength and high abrasion and tear resistant. Chemical resistant within pH 3-10 and ozone, oil, and flame resistant. Used up to 70°C water temperature. Cables < 10 mm ² with unscreened control cores.
Y/D start	Flygt SUBCAB® - a heavy duty 7 cores motor power cable with two twisted pair screened control cores. Conductor insulation rating of 90°C, which allows for increased current. Superior mechanical strength and high abrasion and tear resistant. Chemical resistant within pH 3-10 and ozone, oil, and flame resistant. Used up to 70°C water temperature. Cables < 7G6 mm ² with unscreened control cores.
Variable Frequency drive	Screened Flygt SUBCAB® - a heavy duty 4 screened cores motor power cable with four twisted pair screened control cores. Conductor insulation rating of 90°C, which allows for increased current. Superior mechanical strength and high abrasion and tear resistant. Chemical resistant within pH 3-10 and ozone, oil, and flame resistant. Used up to 70°C water temperature.

Monitoring equipment

Thermal contacts opening temperature 125° C (257° F)

Materials

Table 13: Major parts except mechanical seals

Denomination	Material	ASTM	EN
Major castings	Cast iron, gray	35B	GJL-250
Pump housing	Cast iron, gray	35B	GJL-250
Impeller	Cast iron, nodular	-	GJS-400-18-LT
Suction cover	Cast iron, Hard-Iron™	A 532 IIIA	GJN-HB555(XCR23)
Lifting handle	Stainless steel	AISI 316L	1.4404, 1.4432, ...
Shaft	Stainless steel	AISI 431	1.4057+QT800
Screws and nuts	Stainless steel, A4	AISI 316L, 316, 316Ti	1.4401, 1.4404, ...

Denomination	Material	ASTM	EN
O-rings, alternative 1	Nitrile rubber (NBR) 70° IRH	-	-
O-rings, alternative 2	Fluorinated rubber (FPM) 70° IRH	-	-
Oil, part no 901752	Medical white oil of paraffin type. Fulfills FDA 172.878 (a)	-	-

Table 14: Mechanical seals

Alternative	Inner seal	Outer seal
1	Carbon/ Aluminum oxide	Corrosion resistant cemented carbide/ Corrosion resistant cemented carbide
2	Carbon/ Aluminum oxide	Silicon carbide/ Silicon carbide
3	Corrosion resistant cemented carbide/ Corrosion resistant cemented carbide	Corrosion resistant cemented carbide/ Corrosion resistant cemented carbide

Surface treatment

Priming	Finish
Painted with a primer, see internal standard M0700.00.0002	Navy gray color NCS 5804-B07G. Two-component high-solid top coating, see internal standard M0700.00.0004 for standard painting and M0700.00.0008 for special painting.

Options

- Warm liquid version (non-explosion proof versions)
- Leakage sensor in the stator housing (FLS)
- Leakage sensor in the oil housing (CLS)
- Surface treatment (Epoxy)
- Zinc anodes
- Other cables

Accessories

Discharge connections, adapters, hose connections, and other mechanical accessories.
Electrical accessories such as pump controller, control panels, starters, monitoring relays, cables.

Motor rating and performance curves

These are examples of motor rating and curves. For more information, please contact your local sales and service representative.

Star-delta starting current is 1/3 of Direct on-line starting current.

LT

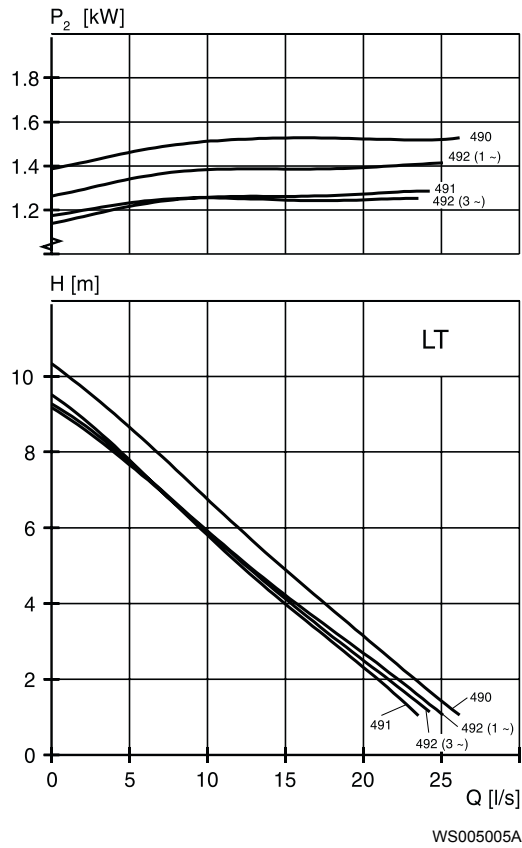

Table 15: 400 V, 50 Hz, 3-phase

Rated power, kW	Rated power, hp	Curve/ Impeller No	Revolutions per minute, rpm	Rated current, A	Starting current, A	Power factor, cos φ	Installation
2	2,7	490	1400	4,8	23	0,8	P,S
2	2,7	491	1400	4,8	23	0,8	P,S
2	2,7	492	1400	4,8	23	0,8	P,S

Table 16: 230 V, 50 Hz, 1-phase

Rated power, kW	Rated power, hp	Curve/ Impeller No	Revolutions per minute, rpm	Rated current, A	Starting current, A	Power factor, cos φ	Installation
1,5	2	492	1425	9,4	43	0,9	P,S

G-pump

Product description



Usage

A submersible pump designed for pumping ground water.

Denomination

Type	Non-explosion proof version	Explosion proof version	Pressure class	Installation types
Cast iron	3085.183	3085.092	MT – Medium head	F

The pump can be used in the following installations:

F Free standing semi permanent, wet well arrangement where the pump is placed on a firm surface.

Application limits

Feature	Description
Liquid temperature	Maximum 40°C (104°F)
Depth of immersion	Maximum 20 m (65 ft)
pH of the pumped liquid	5.5 - 14
Liquid density	Maximum 1100 kg/m ³

Motor data

Feature	Description
Motor type	Squirrel-cage induction motor
Frequency	50 Hz
Power supply	1-phase or 3-phase
Starting method	<ul style="list-style-type: none"> • Direct on-line • Star-delta • Soft starter • Variable Frequency Drive (VFD)
Number of starts per hour	Maximum 30
Code compliance	IEC 60034-1

Feature	Description
Voltage variation	<ul style="list-style-type: none"> Continuously running: Maximum $\pm 5\%$ Intermittent running: Maximum $\pm 10\%$
Voltage imbalance between phases	Maximum 2%
Stator insulation class	H (180°C, 356°F)

Cables

Application	Type
Direct-on-line start or Y/D start with two cables	Flygt SUBCAB® - a heavy duty 4 cores motor power cable with two twisted pair screened control cores. Conductor insulation rating of 90°C, which allows for increased current. Superior mechanical strength and high abrasion and tear resistant. Chemical resistant within pH 3-10 and ozone, oil, and flame resistant. Used up to 70°C water temperature. Cables < 10 mm ² with unscreened control cores.
Y/D start	Flygt SUBCAB® - a heavy duty 7 cores motor power cable with two twisted pair screened control cores. Conductor insulation rating of 90°C, which allows for increased current. Superior mechanical strength and high abrasion and tear resistant. Chemical resistant within pH 3-10 and ozone, oil, and flame resistant. Used up to 70°C water temperature. Cables < 7G6 mm ² with unscreened control cores.
Variable Frequency drive	Screened Flygt SUBCAB® - a heavy duty 4 screened cores motor power cable with four twisted pair screened control cores. Conductor insulation rating of 90°C, which allows for increased current. Superior mechanical strength and high abrasion and tear resistant. Chemical resistant within pH 3-10 and ozone, oil, and flame resistant. Used up to 70°C water temperature.

Monitoring equipment

Thermal contacts opening temperature 125° C (257° F)

Materials

Table 17: Major parts except mechanical seals

Denomination	Material	ASTM	EN
Major castings	Cast iron, gray	35B	GJL-250
Pump housing	Cast iron, gray	35B	GJL-250
Impeller	Cast iron, gray	35B	GJL-250
Strainer bottom	Stainless steel	AISI 304	1.4301
Cutter plate	Steel, stainless steel	-	-
Lifting handle	Stainless steel	AISI 316L	1.4404, 1.4432, ...
Shaft	Stainless steel	AISI 431	1.4057+QT800
Screws and nuts	Stainless steel, A4	AISI 316L, 316, 316Ti	1.4401, 1.4404, ...
O-rings	Nitrile rubber (NBR) 70° IRH	-	-
Oil, part no 901752	Medical white oil of paraffin type. Fulfills FDA 172.878 (a)	-	-

Table 18: Mechanical seals

Alternative	Inner seal	Outer seal
1	Carbon/ Aluminum oxide	Corrosion resistant cemented carbide/ Corrosion resistant cemented carbide
2	Carbon/ Aluminum oxide	Silicon carbide/ Silicon carbide
3	Corrosion resistant cemented carbide/ Corrosion resistant cemented carbide	Corrosion resistant cemented carbide/ Corrosion resistant cemented carbide

Surface treatment

Priming	Finish
Painted with a primer, see internal standard M0700.00.0002	Navy gray color NCS 5804-B07G. Two-component high-solid top coating, see internal standard M0700.00.0004 for standard painting and M0700.00.0008 for special painting.

Options

- Leakage sensor in the oil housing (CLS)
- Leakage sensor in the stator housing (FLS)
- Surface treatment (Epoxy)
- Other cables

Accessories

Discharge connections, adapters, hose connections, and other mechanical accessories. Electrical accessories such as pump controller, control panels, starters, monitoring relays, cables.

Motor rating and performance curves

These are examples of motor rating and curves. For more information, please contact your local sales and service representative.

Star-delta starting current is 1/3 of Direct on-line starting current.

MT

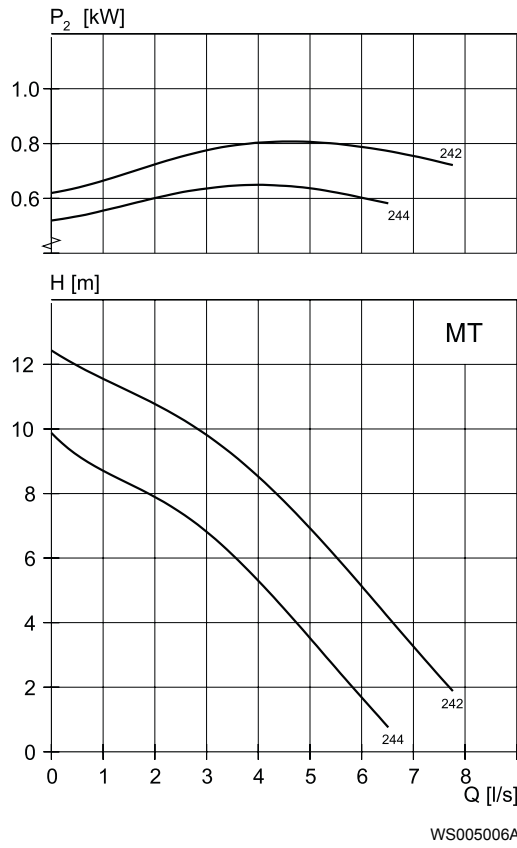

Table 19: 400 V, 50 Hz, 3-phase

Rated power, kW	Rated power, hp	Curve/ Impeller No	Revolutions per minute, rpm	Rated current, A	Starting current, A	Power factor, cos ϕ	Installation
0,77	1	242	2775	1,7	7,5	0,9	F
0,77	1	244	2775	1,7	7,5	0,9	F

Table 20: 230 V, 50 Hz, 1-phase

Rated power, kW	Rated power, hp	Curve/ Impeller No	Revolutions per minute, rpm	Rated current, A	Starting current, A	Power factor, cos ϕ	Installation
0,77	1	242	2785	3	13	0,9	F
0,77	1	244	2785	3	13	0,9	F

M-pump

Product description



Usage

A submersible pump for wastewater containing solids that need to be macerated. The impeller is equipped with a grinder device.

Denomination

Type	Non-explosion proof version	Explosion proof version	Pressure class	Installation types
Cast iron Grinder	3085.172	3085.891	HT – High head	F, H, P

The pump can be used in the following installations:

- F Free standing semi permanent, wet well arrangement where the pump is placed on a firm surface.
- H Semi permanent, wet well quick connection suspended arrangement, incorporating integral non-return valve.
- P Semi permanent, wet well arrangement with pump installed on two guide bars with automatic connection to discharge.

Application limits

Feature	Description
Liquid temperature	Maximum 40°C (104°F)
Depth of immersion	Maximum 20 m (65 ft)
pH of the pumped liquid	5.5 - 14
Liquid density	Maximum 1100 kg/m ³

Motor data

Feature	Description
Motor type	Squirrel-cage induction motor
Frequency	50 Hz
Power supply	1-phase or 3-phase

Feature	Description
Starting method	<ul style="list-style-type: none"> • Direct on-line • Star-delta • Soft starter
Number of starts per hour	Maximum 30
Code compliance	IEC 60034-1
Voltage variation	<ul style="list-style-type: none"> • Continuously running: Maximum $\pm 5\%$ • Intermittent running: Maximum $\pm 10\%$
Voltage imbalance between phases	Maximum 2%
Stator insulation class	H (180°C, 356°F)

Cables

Application	Type
Direct-on-line start or Y/D start with two cables	Flygt SUBCAB® - a heavy duty 4 cores motor power cable with two twisted pair screened control cores. Conductor insulation rating of 90°C, which allows for increased current. Superior mechanical strength and high abrasion and tear resistant. Chemical resistant within pH 3-10 and ozone, oil, and flame resistant. Used up to 70°C water temperature. Cables < 10 mm ² with unscreened control cores.
Y/D start	Flygt SUBCAB® - a heavy duty 7 cores motor power cable with two twisted pair screened control cores. Conductor insulation rating of 90°C, which allows for increased current. Superior mechanical strength and high abrasion and tear resistant. Chemical resistant within pH 3-10 and ozone, oil, and flame resistant. Used up to 70°C water temperature. Cables < 7G6 mm ² with unscreened control cores.

Monitoring equipment

Thermal contacts opening temperature 125° C (257° F)

Materials

Table 21: Major parts except mechanical seals

Denomination	Material	ASTM	EN
Major castings	Cast iron, gray	35B	GJL-250
Pump housing	Cast iron, gray	35B	GJL-250
Impeller	Cast iron, gray	30B	GJL-200
Cutter wheel	Cast iron, Hard-Iron™	A 532 IIIA	GJN-HB555(XCR23)
Cutter plate	Steel, stainless steel	-	-
Lifting handle	Stainless steel	AISI 316L	1.4404, 1.4432, ...
Shaft	Stainless steel	AISI 431	1.4057+QT800
Screws and nuts	Stainless steel, A4	AISI 316L, 316, 316Ti	1.4401, 1.4404, ...
O-rings	Nitrile rubber (NBR) 70° IRH	-	-
Oil, part no 901752	Medical white oil of paraffin type. Fulfills FDA 172.878 (a)	-	-

Table 22: Mechanical seals

Alternative	Inner seal	Outer seal
1	Carbon/ Aluminum oxide	Corrosion resistant cemented carbide/ Corrosion resistant cemented carbide
2	Carbon/ Aluminum oxide	Silicon carbide/ Silicon carbide

Surface treatment

Priming	Finish
Painted with a primer, see internal standard M0700.00.0002	Navy gray color NCS 5804-B07G. Two-component high-solid top coating, see internal standard M0700.00.0004 for standard painting and M0700.00.0008 for special painting.

Options

- Leakage sensor in the stator housing (FLS)
- Leakage sensor in the oil housing (CLS)
- Surface treatment (Epoxy)
- Zinc anodes
- Other cables

Accessories

Discharge connections, adapters, hose connections, and other mechanical accessories.
Electrical accessories such as pump controller, control panels, starters, monitoring relays, cables.

Motor rating and performance curves

These are examples of motor rating and curves. For more information, please contact your local sales and service representative.

Star-delta starting current is 1/3 of Direct on-line starting current.

HT

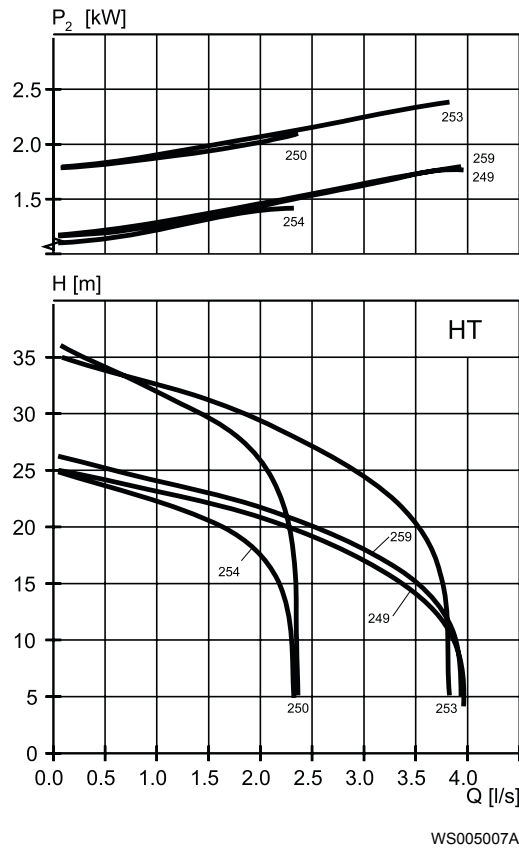

Table 23: 400 V, 50 Hz, 3-phase

Rated power, kW	Rated power, hp	Curve/ Impeller No	Revolutions per minute, rpm	Rated current, A	Starting current, A	Power factor, $\cos \varphi$	Installation
2,4	3,2	250	2845	4,8	29	0,9	F,H,P
2,4	3,2	253	2845	4,8	29	0,9	F,H,P
2,4	3,2	254	2845	4,8	29	0,9	F,H,P
2,4	3,2	259	2845	4,8	29	0,9	F,H,P
1,8	2,4	254	2890	3,6	29	0,87	F,H,P
1,8	2,4	259	2890	3,6	29	0,87	F,H,P

Table 24: 230 V, 50 Hz, 1-phase

Rated power, kW	Rated power, hp	Curve/ Impeller No	Revolutions per minute, rpm	Rated current, A	Starting current, A	Power factor, $\cos \varphi$	Installation
1,9	2,5	249	2915	12	61	0,87	F,H,P
1,9	2,5	254	2915	12	61	0,87	F,H,P

N-pump, Standard Motor

Product description



Usage

A submersible pump for efficient pumping of clean water, surface water, and wastewater containing solids or long-fibered material. The pump is designed for sustained high efficiency. For abrasive media, Hard-Iron™ is required. Stainless steel N-impeller is available as an option.

Denomination

Type	Non-explosion proof version	Explosion proof version	Pressure class	Installation types
Adaptive	3085.160	3085.190	MT – Medium head SH – Super head	F, P, S, T, Z
Cast iron Curve 460, 461, 463, and 253-256	3085.183	3085.092	MT – Medium head SH – Super head	F, P, S, T, Z
Hard-Iron™ Curve 464, 465, 466	3085.183	3085.092	MT – Medium head	F, P, S, T, Z
Stainless steel	3085.760	3085.770	MT – Medium head SH – Super head	P, S

The pump can be used in the following installations:

- F Free standing semi permanent, wet well arrangement where the pump is placed on a firm surface.
- P Semi permanent, wet well arrangement with pump installed on two guide bars with automatic connection to discharge.
- S Portable semi permanent, wet well arrangement with hose coupling or flange for connection to discharge pipeline.
- T Vertical permanent, dry well arrangement with flange connection to suction and discharge piping.
- Z Horizontal permanent, dry well arrangement with flange connection to suction and discharge piping.

Application limits

Feature	Description
Liquid temperature	Maximum 40°C (104°F)
Liquid temperature, warm water version	Maximum 70°C (158°F)
Depth of immersion	Maximum 20 m (65 ft)
pH of the pumped liquid	5.5 - 14
Liquid density	Maximum 1100 kg/m ³

Motor data

Feature	Description
Motor type	Squirrel-cage induction motor
Frequency	50 Hz
Power supply	1-phase or 3-phase
Starting method	<ul style="list-style-type: none"> • Direct on-line • Star-delta • Soft starter • Variable Frequency Drive (VFD)
Number of starts per hour	Maximum 30
Code compliance	IEC 60034-1
Voltage variation	<ul style="list-style-type: none"> • Continuously running: Maximum $\pm 5\%$ • Intermittent running: Maximum $\pm 10\%$
Voltage imbalance between phases	Maximum 2%
Stator insulation class	H (180°C, 356°F)

Cables

Application	Type
Direct-on-line start or Y/D start with two cables	Flygt SUBCAB® - a heavy duty 4 cores motor power cable with two twisted pair screened control cores. Conductor insulation rating of 90°C, which allows for increased current. Superior mechanical strength and high abrasion and tear resistant. Chemical resistant within pH 3-10 and ozone, oil, and flame resistant. Used up to 70°C water temperature. Cables < 10 mm ² with unscreened control cores.
Y/D start	Flygt SUBCAB® - a heavy duty 7 cores motor power cable with two twisted pair screened control cores. Conductor insulation rating of 90°C, which allows for increased current. Superior mechanical strength and high abrasion and tear resistant. Chemical resistant within pH 3-10 and ozone, oil, and flame resistant. Used up to 70°C water temperature. Cables < 7G6 mm ² with unscreened control cores.
Variable Frequency drive	Screened Flygt SUBCAB® - a heavy duty 4 screened cores motor power cable with four twisted pair screened control cores. Conductor insulation rating of 90°C, which allows for increased current. Superior mechanical strength and high abrasion and tear resistant. Chemical resistant within pH 3-10 and ozone, oil, and flame resistant. Used up to 70°C water temperature.

Monitoring equipment

Thermal contacts opening temperature 125° C (257° F)

Materials

Table 25: Major parts except mechanical seals

Denomination	Material	ASTM	EN
Major castings	Cast iron, gray	35B	GJL-250
Pump housing	Cast iron, gray	35B	GJL-250
Impeller, alternative 1	Cast iron, gray	35B	GJL-250
Impeller, alternative 2	Cast iron, Hard-Iron™	A 532 IIIA	GJN-HB555(XCR23)
Impeller, alternative 3	Stainless steel, Duplex	CD-4MCuN	10283:2010 -1.4474
Insert ring, alternative 1	Cast iron, gray	35B	GJL-250
Insert ring, alternative 2	Cast iron, Hard-Iron™	A 532 IIIA	GJN-HB555(XCR23)
Lifting handle	Stainless steel	AISI 316L	1.4404,1.4432, ...
Shaft	Stainless steel	AISI 431	1.4057+QT800
Screws and nuts	Stainless steel, A4	AISI 316L, 316, 316Ti	1.4401,1.4404, ...
O-rings, alternative 1	Nitrile rubber (NBR) 70° IRH	-	-
O-rings, alternative 2	Fluorinated rubber (FPM) 70° IRH	-	-
Oil, part no 901752	Medical white oil of paraffin type. Fulfills FDA 172.878 (a)	-	-

Table 26: Mechanical seals

Alternative	Inner seal	Outer seal
1	Carbon/ Aluminum oxide	Corrosion resistant cemented carbide/ Corrosion resistant cemented carbide
2	Carbon/ Aluminum oxide	Silicon carbide/ Silicon carbide
3	Corrosion resistant cemented carbide/ Corrosion resistant cemented carbide	Corrosion resistant cemented carbide/ Corrosion resistant cemented carbide

Surface treatment

Priming	Finish
Painted with a primer, see internal standard M0700.00.0002	Navy gray color NCS 5804-B07G. Two-component high-solid top coating, see internal standard M0700.00.0004 for standard painting and M0700.00.0008 for special painting.

Options

- Warm liquid version (non-explosion proof versions)
- Leakage sensor in the stator housing (FLS)
- Leakage sensor in the oil housing (CLS)
- Surface treatment (Epoxy)
- Zinc anodes
- Other cables

Accessories

Discharge connections, adapters, hose connections, and other mechanical accessories.
Electrical accessories such as pump controller, control panels, starters, monitoring relays, cables.

Motor rating and performance curves 3085.183/.092

These are examples of motor rating and curves. For more information, please contact your local sales and service representative.

Star-delta starting current is 1/3 of Direct on-line starting current.

MT

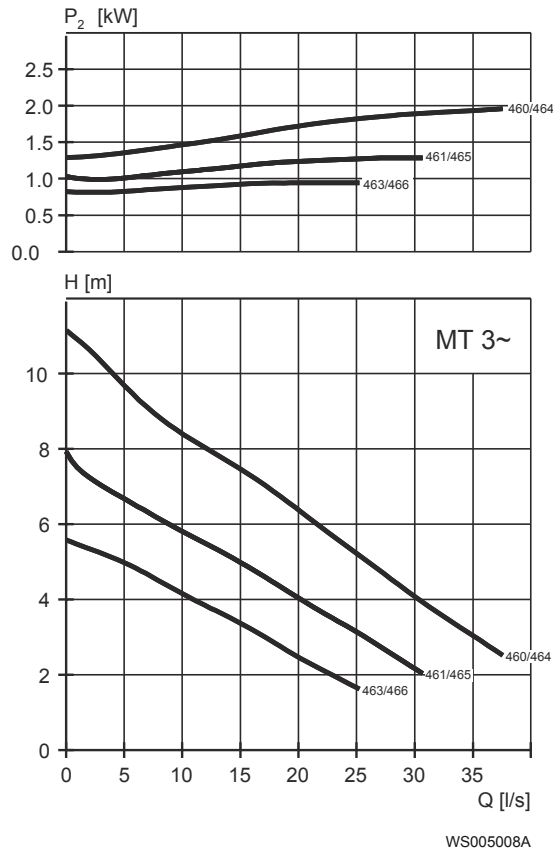
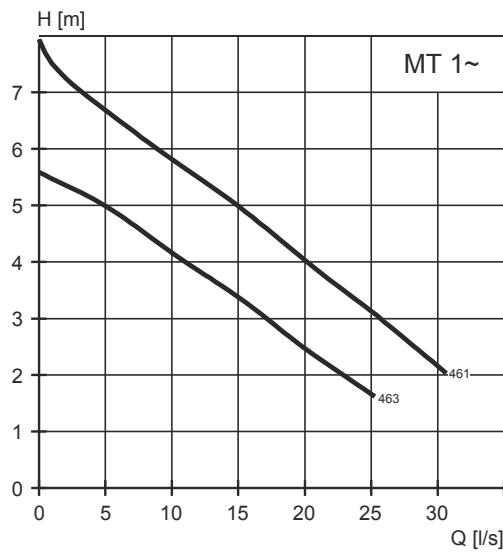
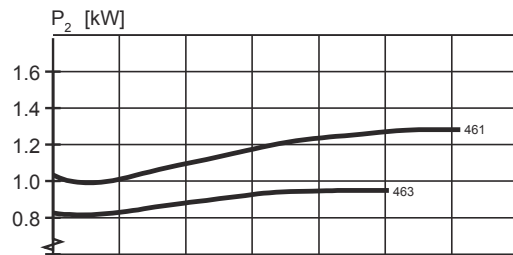

Table 27: 400 V, 50 Hz, 3-phase

Rated power, kW	Rated power, hp	Curve/ Impeller No	Revolutions per minute, rpm	Rated current, A	Starting current, A	Power factor, cos φ	Installation
1	1,3	463	1455	3,2	23	0,6	T,Z
1	1,3	466	1455	3,2	23	0,6	T,Z
1,3	1,7	461	1440	3,6	23	0,68	F,P,S
1,3	1,7	463	1440	3,6	23	0,68	F,P,S
1,3	1,7	465	1440	3,6	23	0,68	F,P,S
1,3	1,7	466	1440	3,6	23	0,68	F,P,S
1,4	1,9	461	1435	3,7	23	0,7	T,Z
1,4	1,9	463	1435	3,7	23	0,7	T,Z
1,4	1,9	465	1435	3,7	23	0,7	T,Z
1,4	1,9	466	1435	3,7	23	0,7	T,Z
2	2,7	460	1415	5,2	27	0,73	F,P,S
2	2,7	461	1415	5,2	27	0,73	F,P,S
2	2,7	463	1415	5,2	27	0,73	F,P,S
2	2,7	464	1415	5,2	27	0,73	F,P,S

Rated power, kW	Rated power, hp	Curve/ Impeller No	Revolutions per minute, rpm	Rated current, A	Starting current, A	Power factor, cos φ	Installation
2	2,7	465	1415	5,2	27	0,73	F,P,S
2	2,7	466	1415	5,2	27	0,73	F,P,S



WS005009A

Table 28: 230 V, 50 Hz, 1-phase

Rated power, kW	Rated power, hp	Curve/ Impeller No	Revolutions per minute, rpm	Rated current, A	Starting current, A	Power factor, cos φ	Installation
1,5	2	461	1425	9,4	43	0,9	P,S
1,5	2	463	1425	9,4	43	0,9	P,S

SH

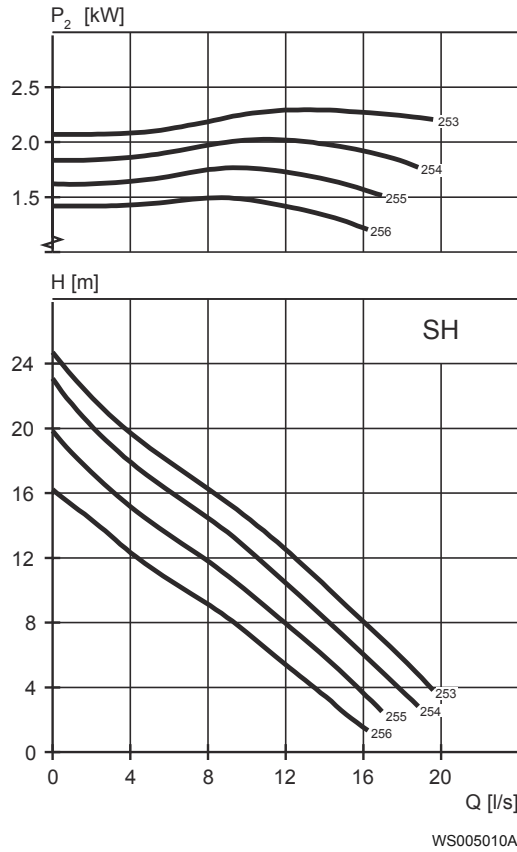

Table 29: 400 V, 50 Hz, 3-phase

Rated power, kW	Rated power, hp	Curve/ Impeller No	Revolutions per minute, rpm	Rated current, A	Starting current, A	Power factor, cos φ	Installation
2,4	3,2	253	2845	4,8	29	0,9	P,S
2,4	3,2	254	2845	4,8	29	0,9	P,S
2,4	3,2	255	2845	4,8	29	0,9	P,S
2,4	3,2	256	2845	4,8	29	0,9	P,S

Motor rating and performance curves 3085.160/.190

These are examples of motor rating and curves. For more information, please contact your local sales and service representative.

Star-delta starting current is 1/3 of Direct on-line starting current.

MT

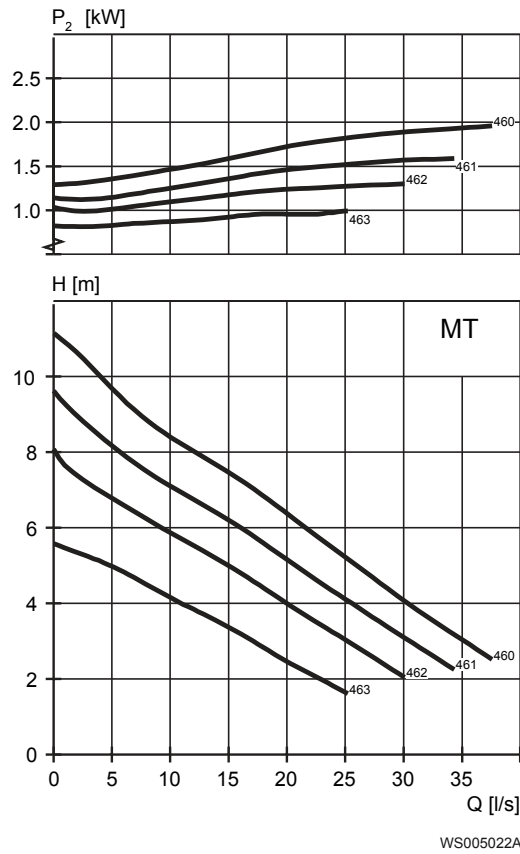
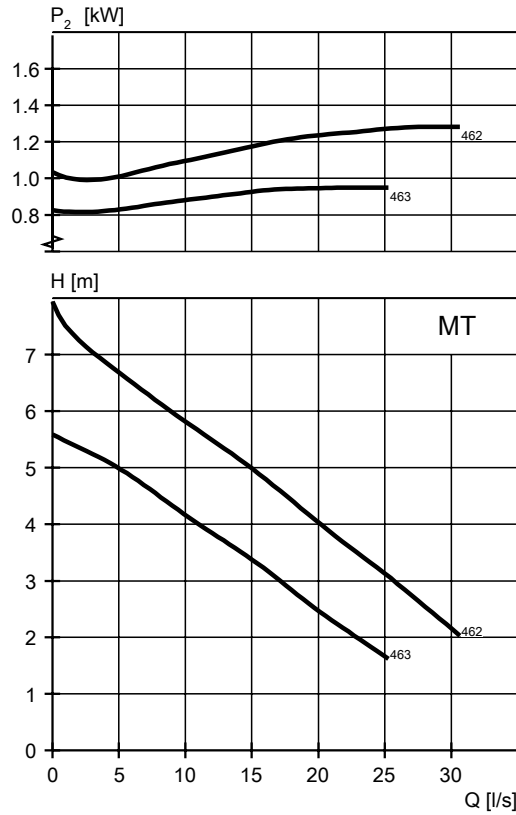

Table 30: 400 V, 50 Hz, 3-phase

Rated power, kW	Rated power, hp	Curve/Impeller No	Revolutions per minute, rpm	Rated current, A	Starting current, A	Power factor, cos φ	Installation
1	1,3	463	1455	3,2	23	0,6	T,Z
1,3	1,7	462	1440	3,6	23	0,68	F,P,S
1,3	1,7	463	1440	3,6	23	0,68	F,P,S
1,4	1,9	462	1435	3,7	23	0,7	T,Z
1,4	1,9	463	1435	3,7	23	0,7	T,Z
2	2,7	460	1400	4,8	23	0,8	F,P,S
2	2,7	461	1400	4,8	23	0,8	F,P,S
2	2,7	462	1400	4,8	23	0,8	F,P,S
2	2,7	463	1400	4,8	23	0,8	F,P,S



WS004116A

Table 31: 230 V, 50 Hz, 1-phase

Rated power, kW	Rated power, hp	Curve/ Impeller No	Revolutions per minute, rpm	Rated current, A	Starting current, A	Power factor, $\cos \varphi$	Installation
1.5	2.0	462	1425	9.4	43	0.9	F,P,S
1.5	2.0	463	1425	9.4	43	0.9	F,P,S

SH

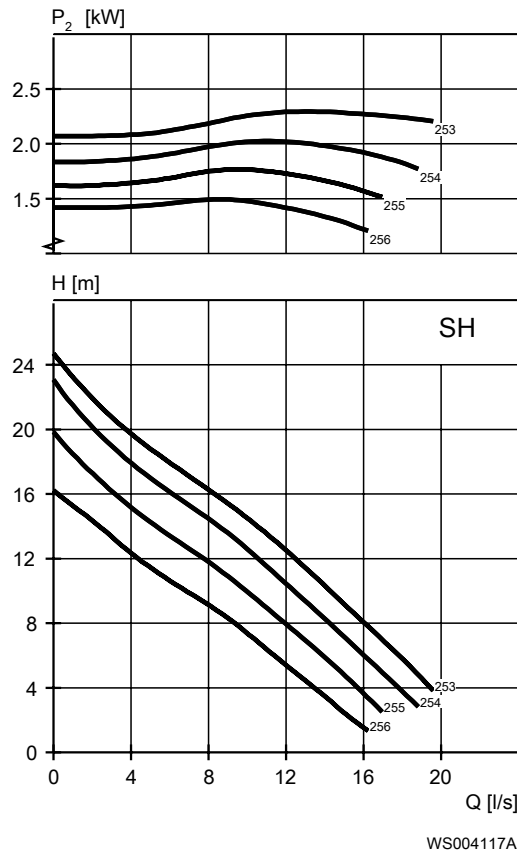

Table 32: 400 V, 50 Hz, 3-phase

Rated power, kW	Rated power, hp	Curve/ Impeller No	Revolutions per minute, rpm	Rated current, A	Starting current, A	Power factor, $\cos \varphi$	Installation
2,4	3,2	253	2845	4,8	29	0,91	P,S
2,4	3,2	254	2845	4,8	29	0,91	P,S
2,4	3,2	255	2845	4,8	29	0,91	P,S
2,4	3,2	256	2845	4,8	29	0,91	P,S
2,4	3,2	253	2870	4,9	34	0,87	P,S
2,4	3,2	254	2870	4,9	34	0,87	P,S
2,4	3,2	255	2870	4,9	34	0,87	P,S
2,4	3,2	256	2870	4,9	34	0,87	P,S

Motor rating and performance curves 3085.760/.770

These are examples of motor rating and curves. For more information, please contact your local sales and service representative.

Star-delta starting current is 1/3 of Direct on-line starting current.

MT

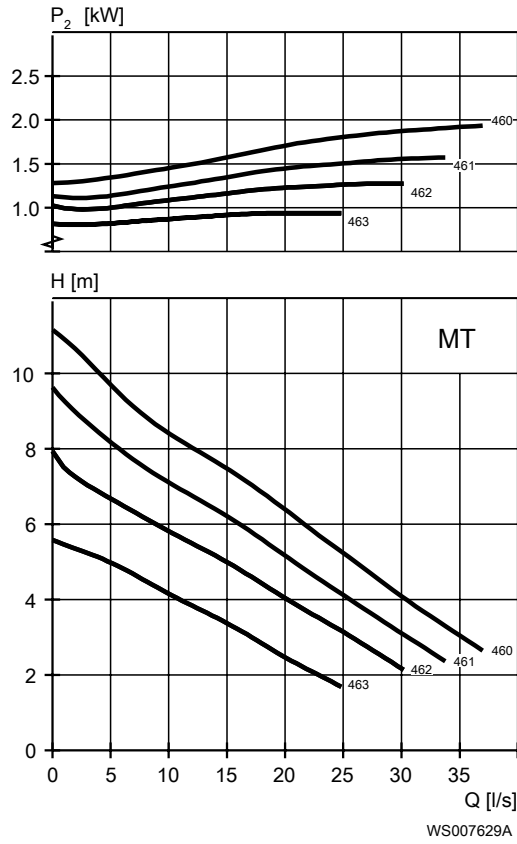

Table 33: 400 V, 50 Hz, 3-phase

Rated power, kW	Rated power, hp	Curve/ Impeller No	Revolutions per minute, rpm	Rated Current, A	Start current, A	Power Factor, cos φ	Installation
1.3	1.7	462	1440	3.6	23	0.68	F,P,S
1.3	1.7	463	1440	3.6	23	0.68	F,P,S
2	2.7	460	1400	4.8	23	0.8	P,S
2	2.7	461	1400	4.8	23	0.8	P,S
2	2.7	462	1400	4.8	23	0.8	F,P,S
2	2.7	463	1400	4.8	23	0.8	F,P,S

SH

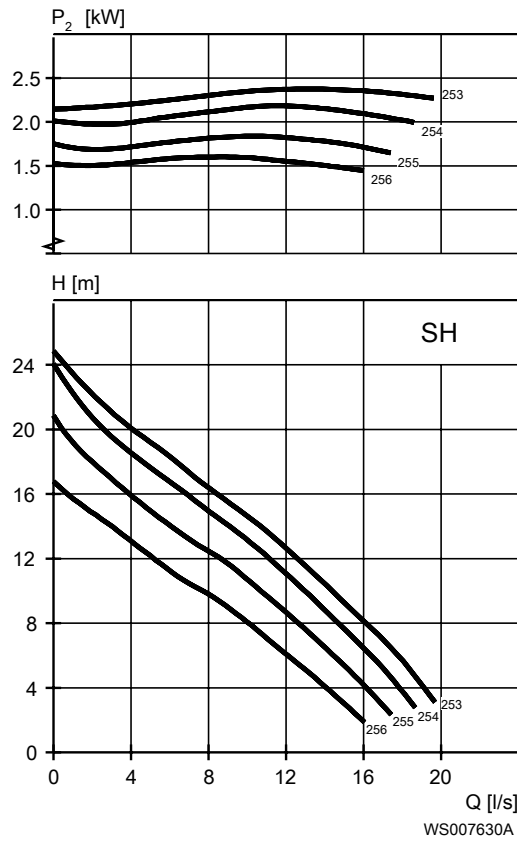

Table 34: 400 V, 50 Hz, 3-phase

Rated power, kW	Rated power, hp	Curve/ Impeller No	Revolutions per minute, rpm	Rated Current, A	Start current, A	Power Factor, cos φ	Installation
2.4	3.2	253	2845	4.8	29	0.91	P,S
2.4	3.2	253	2870	4.9	34	0.87	P,S
2.4	3.2	254	2845	4.8	29	0.91	P,S
2.4	3.2	254	2870	4.9	34	0.87	P,S
2.4	3.2	255	2845	4.8	29	0.91	P,S
2.4	3.2	255	2870	4.9	34	0.87	P,S
2.4	3.2	256	2845	4.8	29	0.91	P,S
2.4	3.2	256	2870	4.9	34	0.87	P,S

N-pump, Premium Efficiency Motor (IE3)

Product description



Usage

A submersible pump for efficient pumping of clean water, surface water, and wastewater containing solids or long-fibered material. The pump is designed for sustained high efficiency. For abrasive media, Hard-Iron™ is required. Stainless steel N-impeller is available as an option.

Denomination

Type	Non-explosion proof version	Explosion proof version	Pressure class	Installation types
Adaptive	3085.900	3085.910	MT – Medium head	F, P, S, T, Z
Cast iron	3085.800	3085.810	MT – Medium head	F, P, S, T, Z
Hard-Iron™	3085.820	3085.830	MT – Medium head	F, P, S, T, Z
Stainless steel	3085.960	3085.970	MT – Medium head	P, S

The pump can be used in the following installations:

- F Free standing semi permanent, wet well arrangement where the pump is placed on a firm surface.
- P Semi permanent, wet well arrangement with pump installed on two guide bars with automatic connection to discharge.
- S Portable semi permanent, wet well arrangement with hose coupling or flange for connection to discharge pipeline.
- T Vertical permanent, dry well arrangement with flange connection to suction and discharge piping.
- Z Horizontal permanent, dry well arrangement with flange connection to suction and discharge piping.

Application limits

Feature	Description
Liquid temperature	Maximum 40°C (104°F)

Feature	Description
Depth of immersion	Maximum 20 m (65 ft)
pH of the pumped liquid	5.5 - 14
Liquid density	Maximum 1100 kg/m ³

Motor data

Feature	Description
Motor type	Line started permanent magnet motor (LSPM)
Frequency	50 Hz
Power supply	1-phase or 3-phase
Starting method	<ul style="list-style-type: none"> • Direct on-line • Star-delta • Soft starter • Variable Frequency Drive (VFD)
Number of starts per hour	Maximum 30
Code compliance	IEC 60034-1
Voltage variation	<ul style="list-style-type: none"> • Continuously running: Maximum $\pm 5\%$ • Intermittent running: Maximum $\pm 10\%$
Voltage imbalance between phases	Maximum 2%
Stator insulation class	H (180°C, 356°F)

Cables

Application	Type
Direct-on-line start or Y/D start with two cables	Flygt SUBCAB® - a heavy duty 4 cores motor power cable with two twisted pair screened control cores. Conductor insulation rating of 90°C, which allows for increased current. Superior mechanical strength and high abrasion and tear resistant. Chemical resistant within pH 3-10 and ozone, oil, and flame resistant. Used up to 70°C water temperature. Cables < 10 mm ² with unscreened control cores.
Y/D start	Flygt SUBCAB® - a heavy duty 7 cores motor power cable with two twisted pair screened control cores. Conductor insulation rating of 90°C, which allows for increased current. Superior mechanical strength and high abrasion and tear resistant. Chemical resistant within pH 3-10 and ozone, oil, and flame resistant. Used up to 70°C water temperature. Cables < 7G6 mm ² with unscreened control cores.
Variable Frequency drive	Screened Flygt SUBCAB® - a heavy duty 4 screened cores motor power cable with four twisted pair screened control cores. Conductor insulation rating of 90°C, which allows for increased current. Superior mechanical strength and high abrasion and tear resistant. Chemical resistant within pH 3-10 and ozone, oil, and flame resistant. Used up to 70°C water temperature.

Monitoring equipment

Thermal contacts opening temperature 125° C (257° F)

Materials

Table 35: Major parts except mechanical seals

Denomination	Material	ASTM	EN
Major castings	Cast iron, gray	35B	GJL-250
Pump housing	Cast iron, gray	35B	GJL-250
Impeller, alternative 1	Cast iron, gray	35B	GJL-250
Impeller, alternative 2	Cast iron, Hard-Iron™	A 532 IIIA	GJN-HB555(XCR23)
Impeller, alternative 3	Stainless steel, Duplex	CD-4MCuN	10283:2010 -1.4474
Insert ring, alternative 1	Cast iron, gray	35B	GJL-250
Insert ring, alternative 2	Cast iron, Hard-Iron™	A 532 IIIA	GJN-HB555(XCR23)
Lifting handle	Stainless steel	AISI 316L	1.4404,1.4432, ...
Shaft	Stainless steel	AISI 431	1.4057+QT800
Screws and nuts	Stainless steel, A4	AISI 316L, 316, 316Ti	1.4401,1.4404, ...
O-rings, alternative 1	Nitrile rubber (NBR) 70° IRH	-	-
O-rings, alternative 2	Fluorinated rubber (FPM) 70° IRH	-	-
Oil, part no 901752	Medical white oil of paraffin type. Fulfills FDA 172.878 (a)	-	-

Table 36: Mechanical seals

Alternative	Inner seal	Outer seal
1	Carbon/ Aluminum oxide	Corrosion resistant cemented carbide/ Corrosion resistant cemented carbide
2	Carbon/ Aluminum oxide	Silicon carbide/ Silicon carbide
3	Corrosion resistant cemented carbide/ Corrosion resistant cemented carbide	Corrosion resistant cemented carbide/ Corrosion resistant cemented carbide

Surface treatment

Priming	Finish
Painted with a primer, see internal standard M0700.00.0002	Navy gray color NCS 5804-B07G. Two-component high-solid top coating, see internal standard M0700.00.0004 for standard painting and M0700.00.0008 for special painting.

Options

- Leakage sensor in the stator housing (FLS)
- Leakage sensor in the oil housing (CLS)
- Surface treatment (Epoxy)
- Zinc anodes
- Other cables

Accessories

Discharge connections, adapters, hose connections, and other mechanical accessories. Electrical accessories such as pump controller, control panels, starters, monitoring relays, cables.

Motor rating and performance curves 3085.800/.810/.820/.830/.900/.910

These are examples of motor rating and curves. For more information, please contact your local sales and service representative.

Star-delta starting current is 1/3 of Direct on-line starting current.

MT

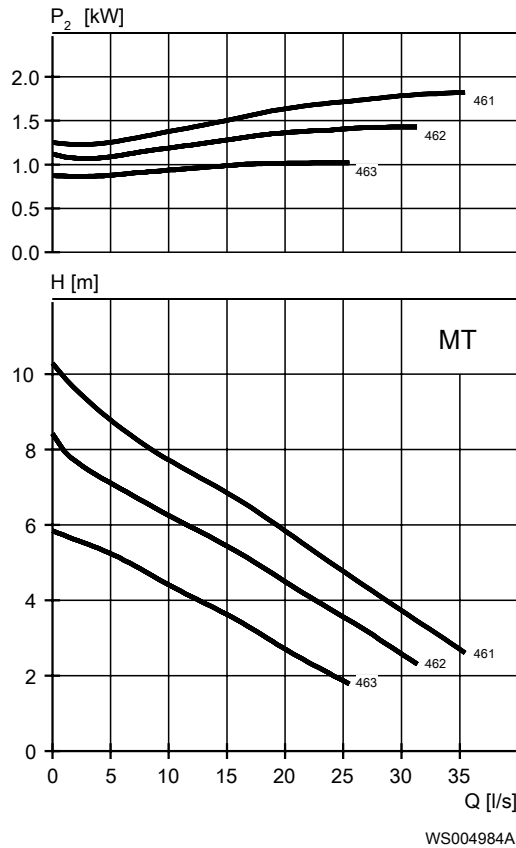

Table 37: 400 V, 50 Hz, 3-phase

Rated power, kW	Rated power, hp	Curve/ Impeller No	Revolutions per minute, rpm	Rated Current, A	Start current, A	Power factor, $\cos \varphi$	Installation
1.6	2.1	462	1500	3.3	23	0.82	P,S,T,Z
1.6	2.1	463	1500	3.3	23	0.82	F,P,S,T,Z
2	2.7	461	1500	3.8	23	0.87	P,S,T,Z
2	2.7	462	1500	3.8	23	0.87	P,S,T,Z
2	2.7	463	1500	3.8	23	0.87	F,P,S,T,Z

Motor rating and performance curves 3085.960/.970

These are examples of motor rating and curves. For more information, please contact your local sales and service representative.

Star-delta starting current is 1/3 of Direct on-line starting current.

MT

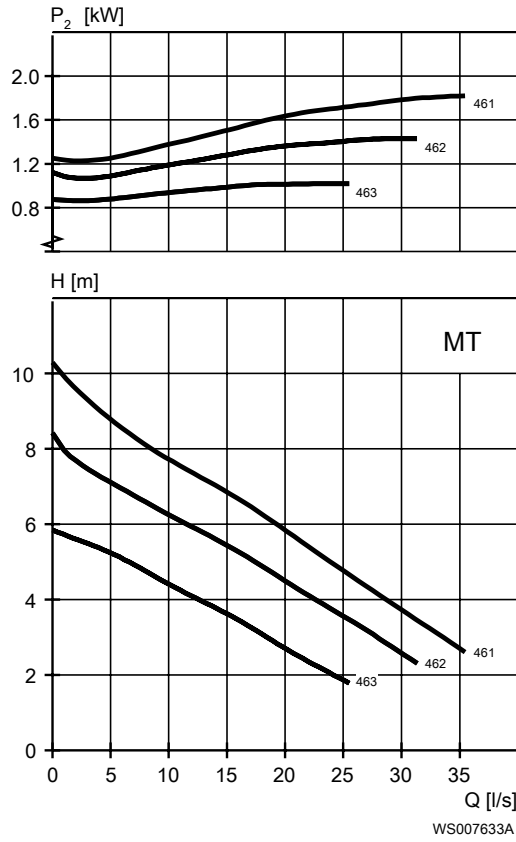

Table 38: 400 V, 50 Hz, 3-phase

Rated power, kW	Rated power, hp	Curve/ Impeller No	Revolutions per minute, rpm	Rated Current, A	Start current, A	Power Factor, $\cos \phi$	Installation
1.6	2.1	462	1500	3.3	23	0.82	F,P,S
1.6	2.1	463	1500	3.3	23	0.82	F,P,S
2	2.7	461	1500	3.8	23	0.87	F,P,S
2	2.7	462	1500	3.8	23	0.87	F,P,S
2	2.7	463	1500	3.8	23	0.87	F,P,S

Dimensions and Weight, C-pump

Drawings

All drawings are available as Acrobat documents (.pdf) and AutoCad drawings (.dwg). Contact your local sales and service representative for more information.

All dimensions are in mm.

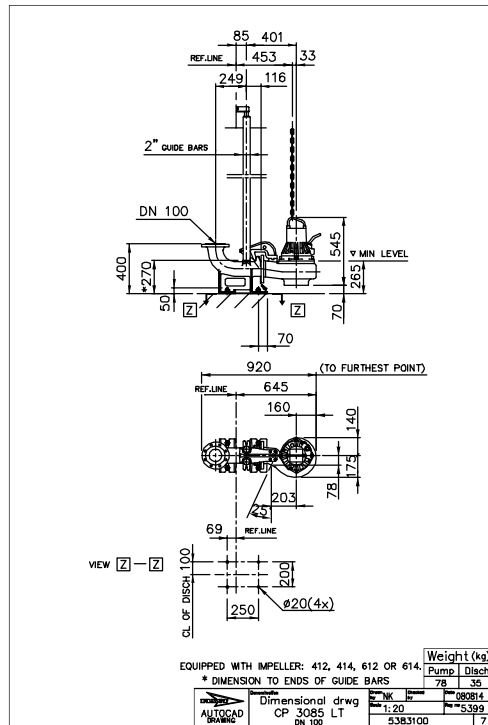

Figure 1: LT, P-installation

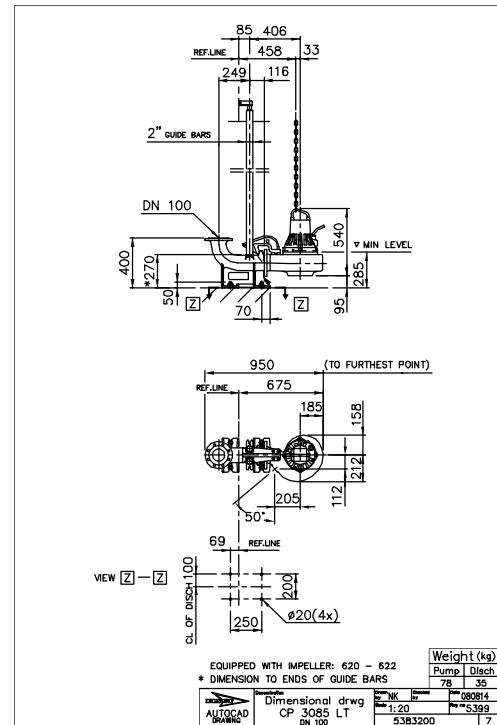

Figure 2: LT, P-installation

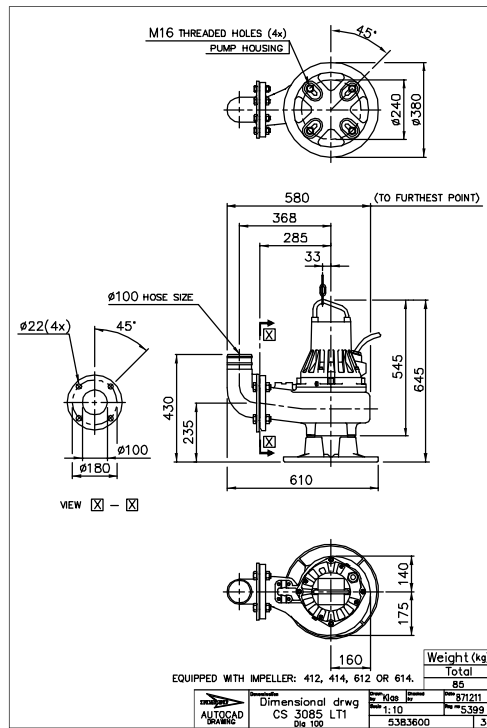

Figure 3: LT, S-installation

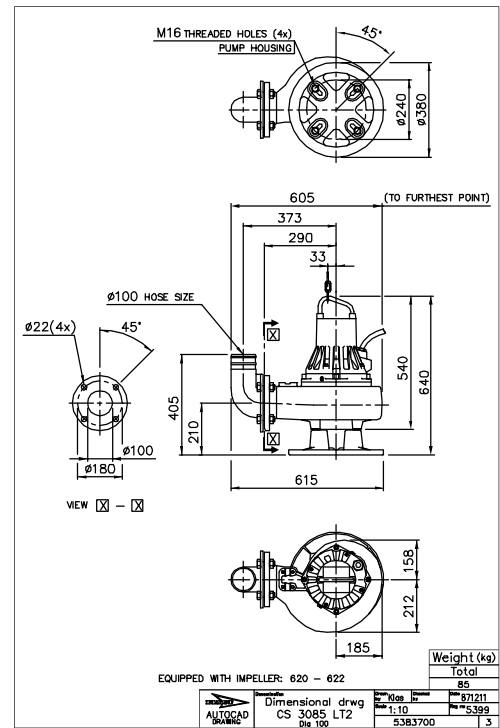

Figure 4: LT, S-installation

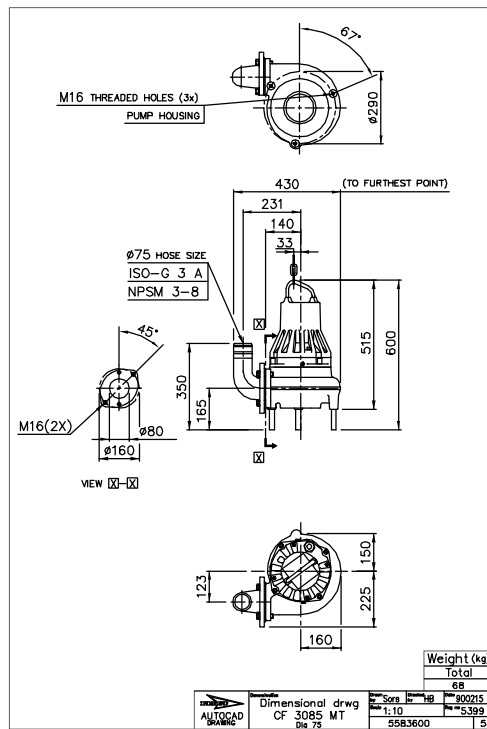

Figure 5: MT, F-installation

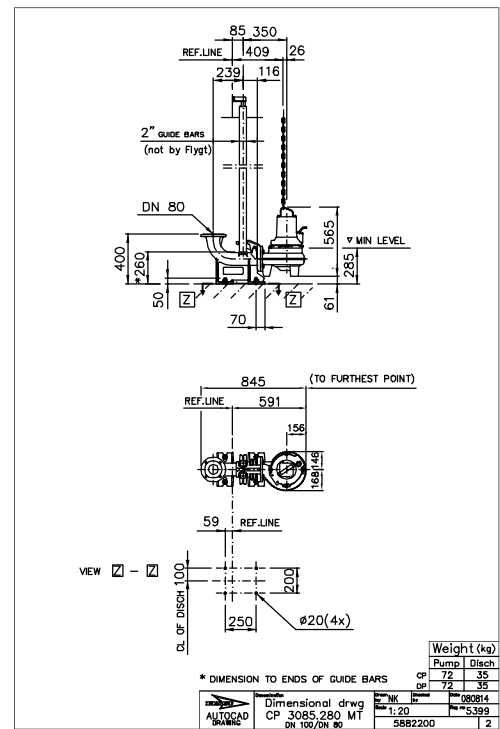

Figure 6: MT, P-installation

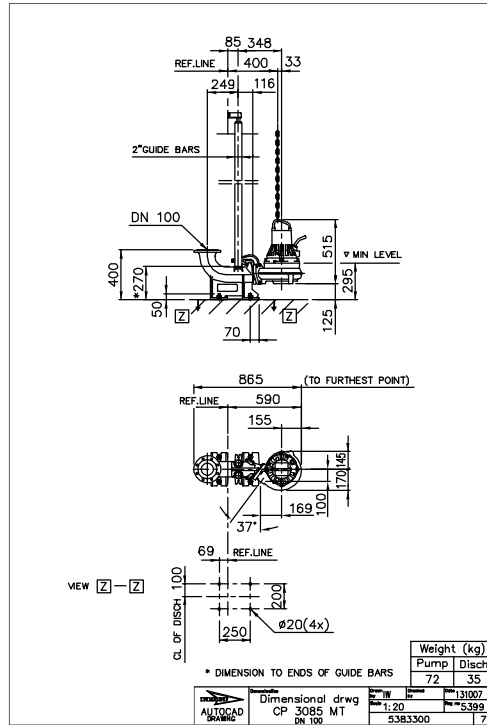

Figure 7: MT, P-installation

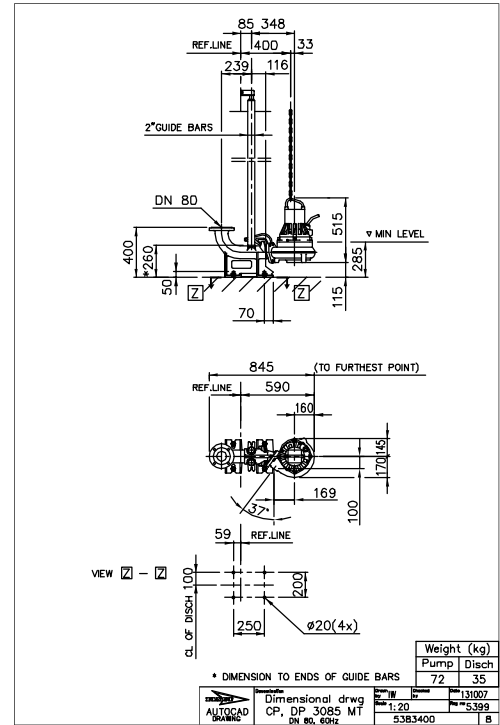

Figure 8: MT, P-installation

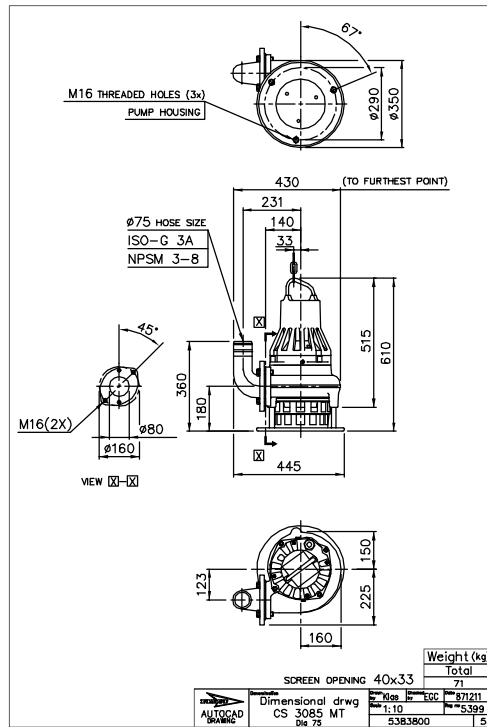

Figure 9: MT, S-installation

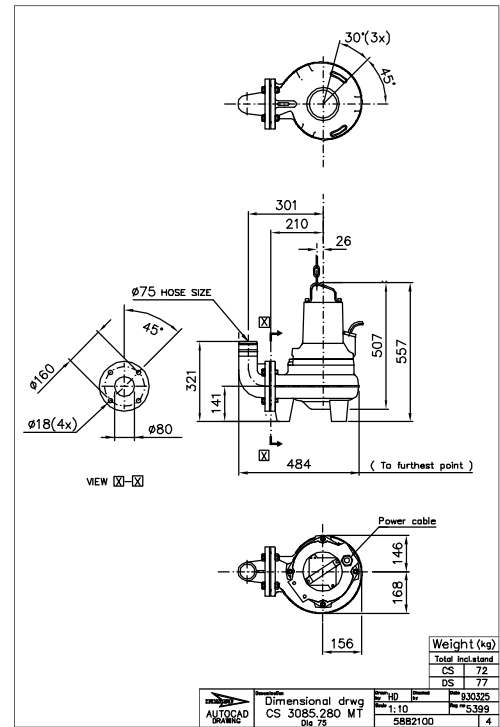

Figure 10: MT, S-installation

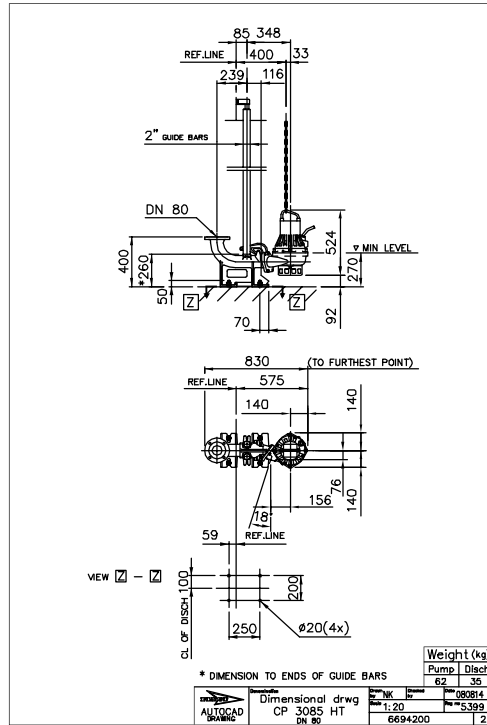

Figure 15: HT, P-installation

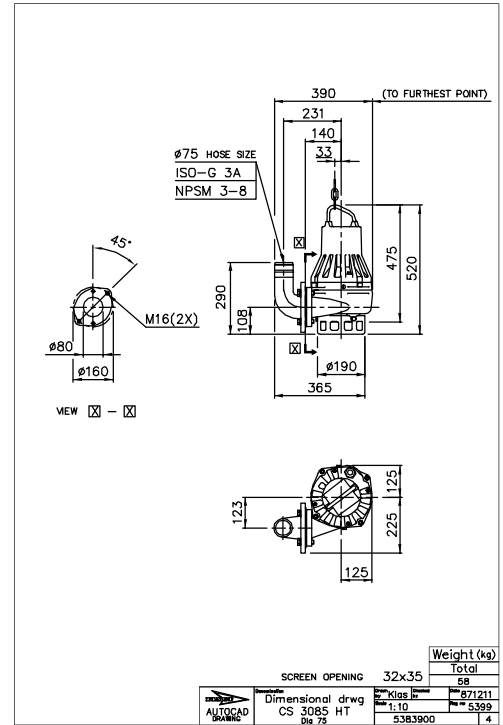

Figure 16: HT, S-installation

Dimensions and Weight, D-pump

Drawings

All drawings are available as Acrobat documents (.pdf) and AutoCad drawings (.dwg). Contact your local sales and service representative for more information.

All dimensions are in mm.

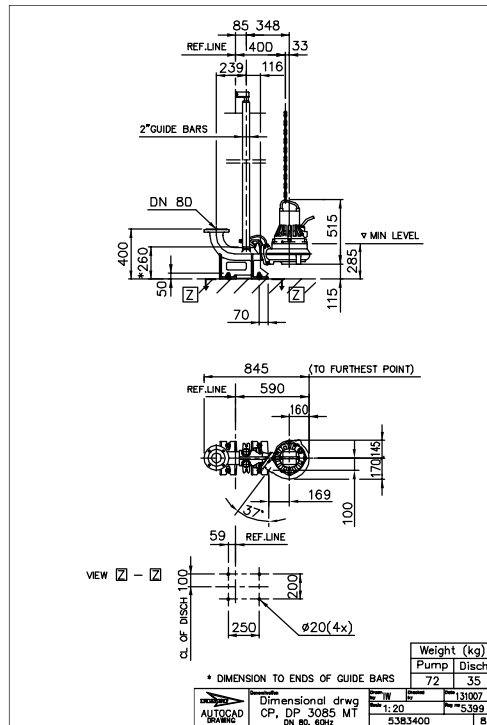

Figure 17: MT, P-installation

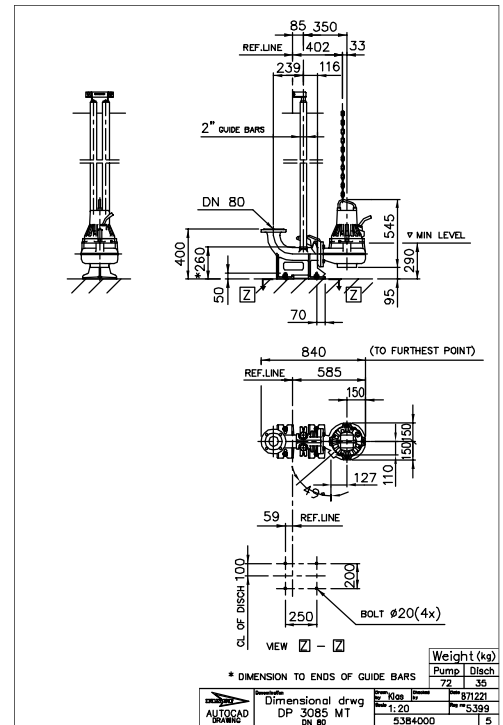

Figure 18: MT, P-installation

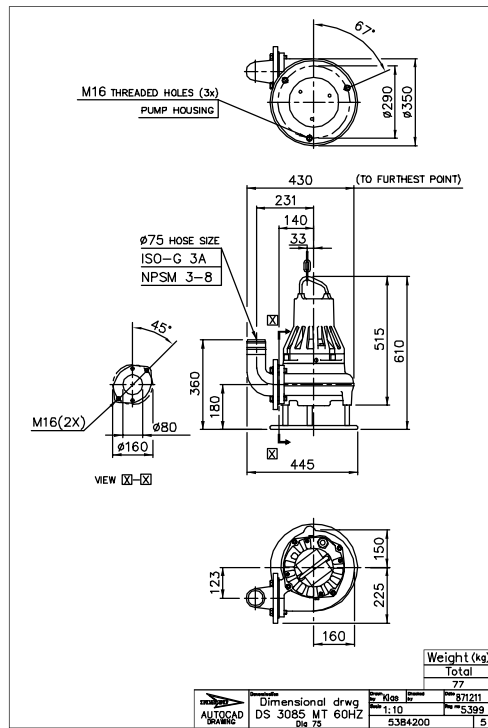

Figure 19: MT, S-installation

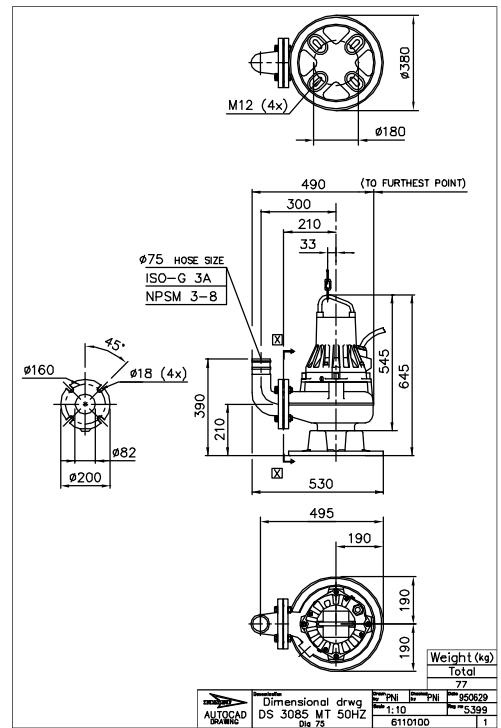

Figure 20: MT, S-installation

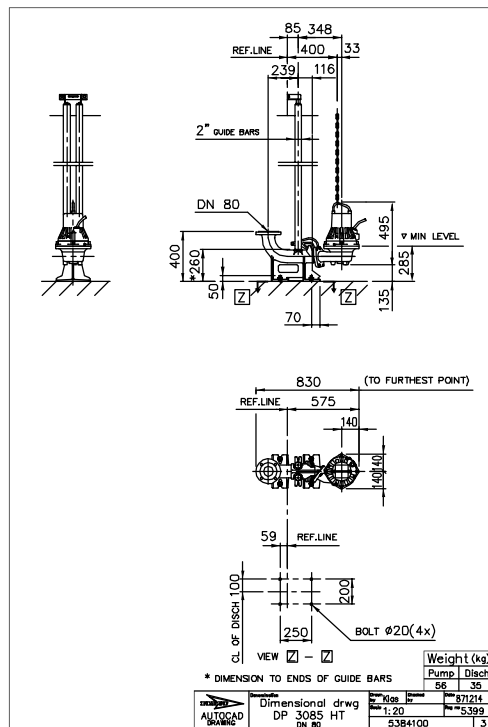

Figure 21: HT, P-installation

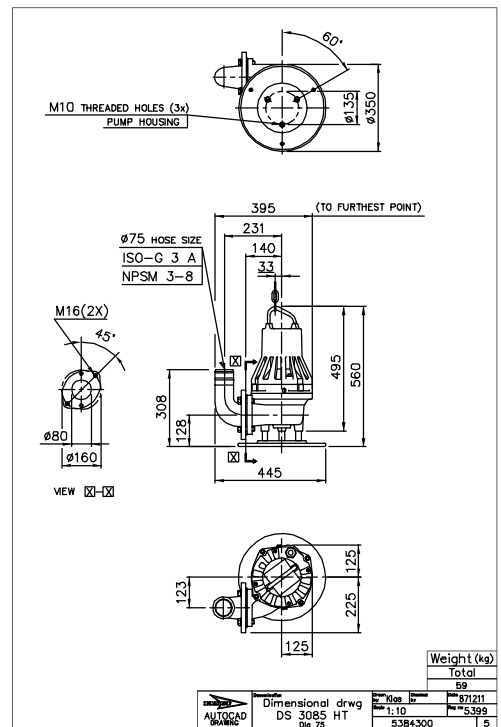

Figure 22: HT, S-installation

Dimensions and Weight, F-pump

Drawings

All drawings are available as Acrobat documents (.pdf) and AutoCad drawings (.dwg). Contact your local sales and service representative for more information.

All dimensions are in mm.

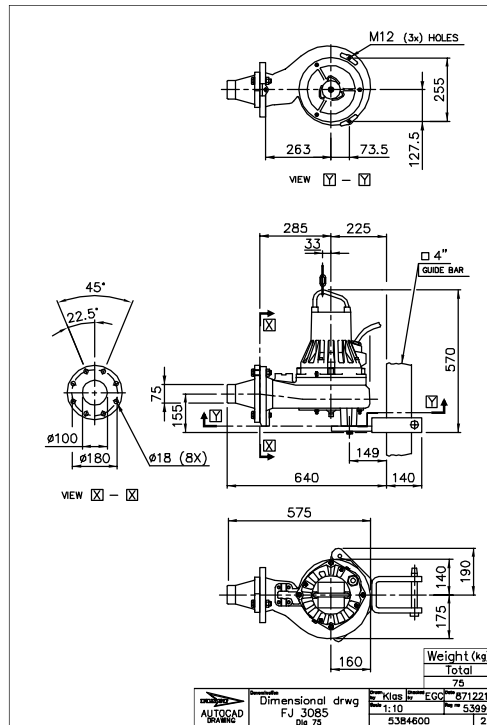

Figure 23: J-installation

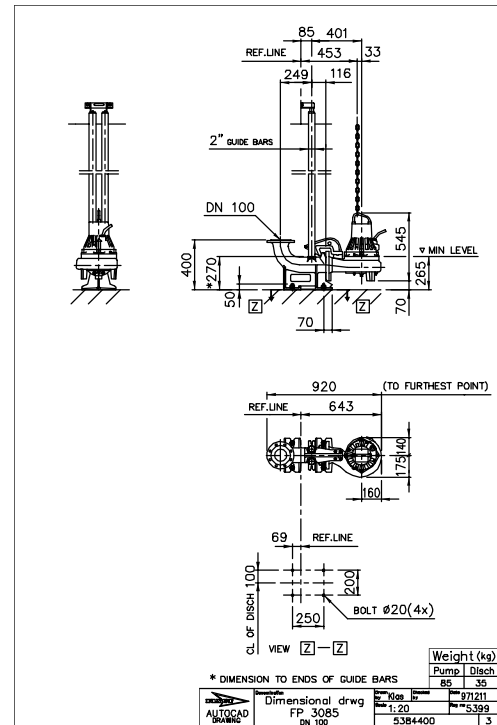

Figure 24: P-installation

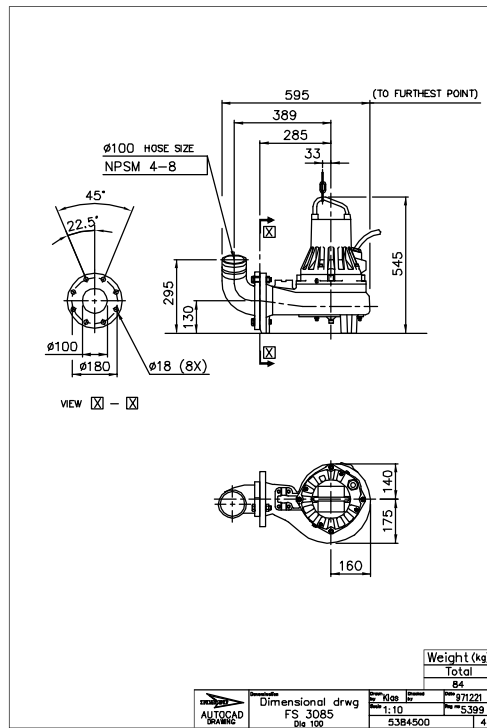

Figure 25: S-installation

Dimensions and Weight, G-pump

Drawings

All drawings are available as Acrobat documents (.pdf) and AutoCad drawings (.dwg).
Contact your local sales and service representative for more information.

All dimensions are in mm.

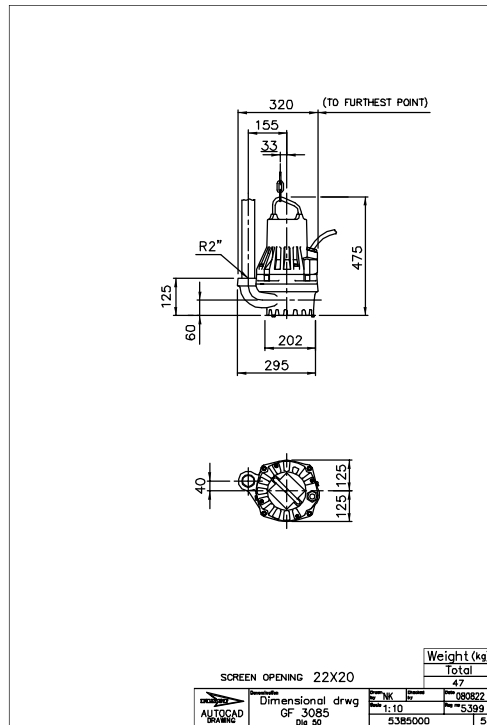

Figure 26: F-installation

Dimensions and Weight, M-pump

Drawings

All drawings are available as Acrobat documents (.pdf) and AutoCad drawings (.dwg). Contact your local sales and service representative for more information.

All dimensions are in mm.

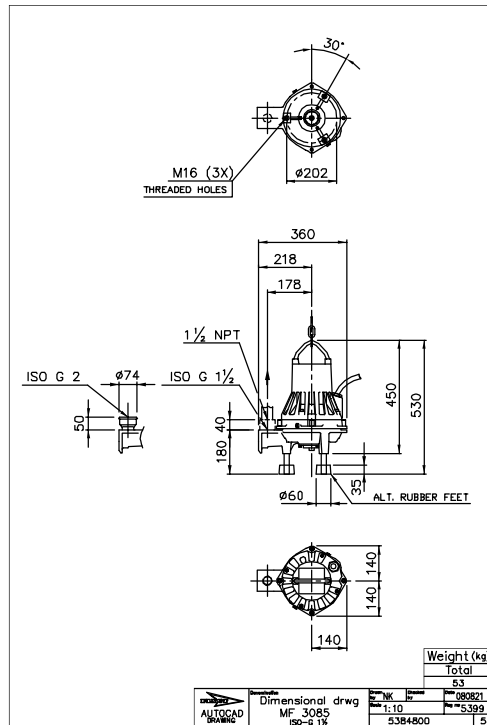

Figure 27: F-installation

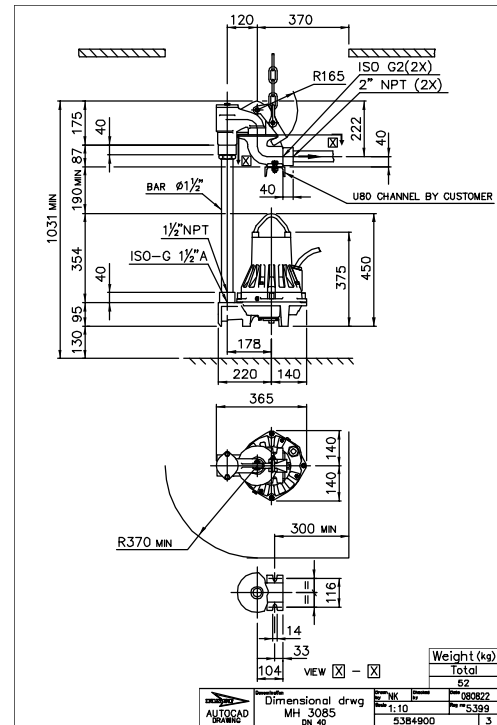

Figure 28: H-installation

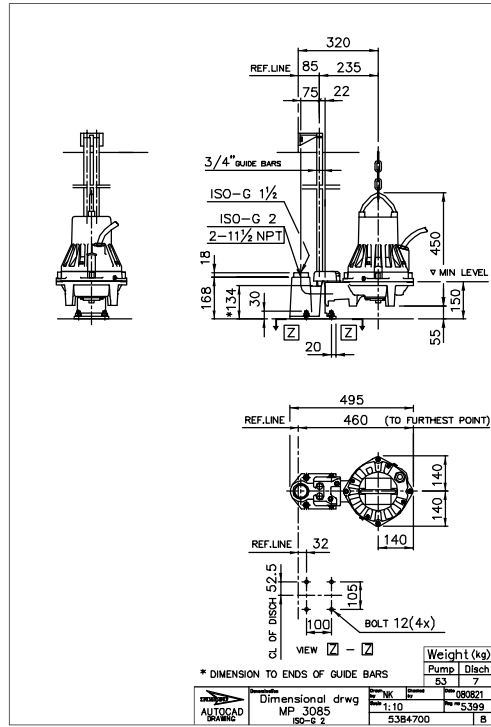

Figure 29: P-installation

Dimensions and Weight, N-pump

Drawings

All drawings are available as Acrobat documents (.pdf) and AutoCad drawings (.dwg). Contact your local sales and service representative for more information. All dimensions are in mm.

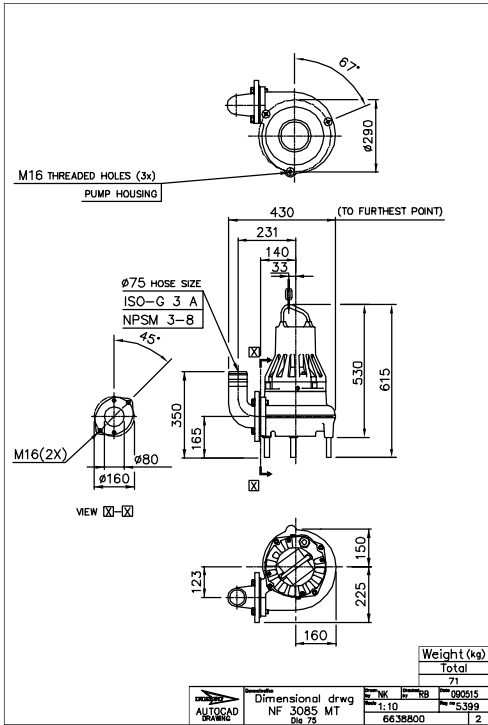

Figure 30: MT, F-installation

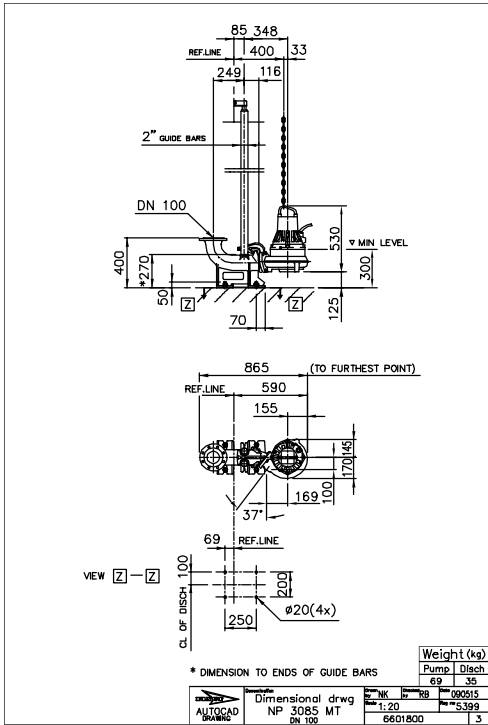

Figure 31: MT, P-installation

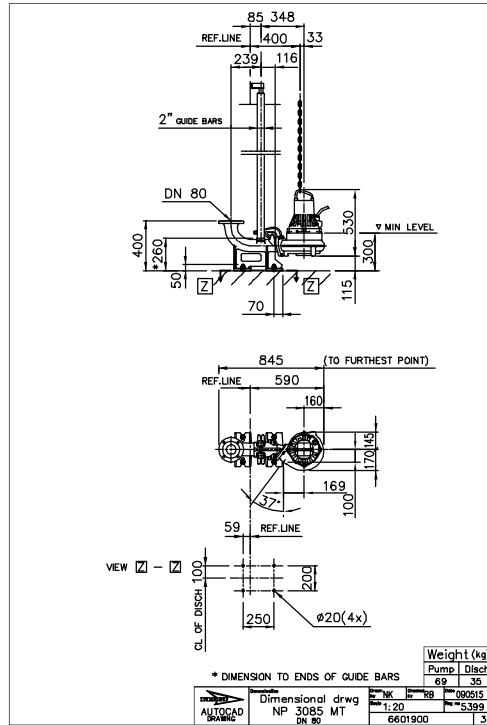

Figure 32: MT, P-installation

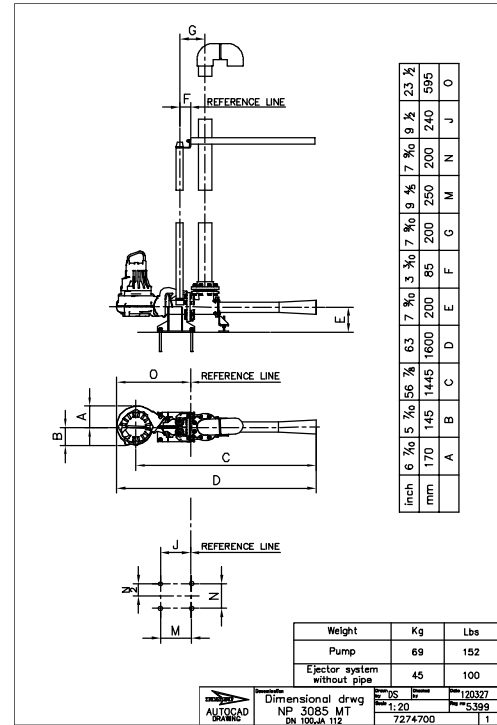

Figure 33: MT, P-installation

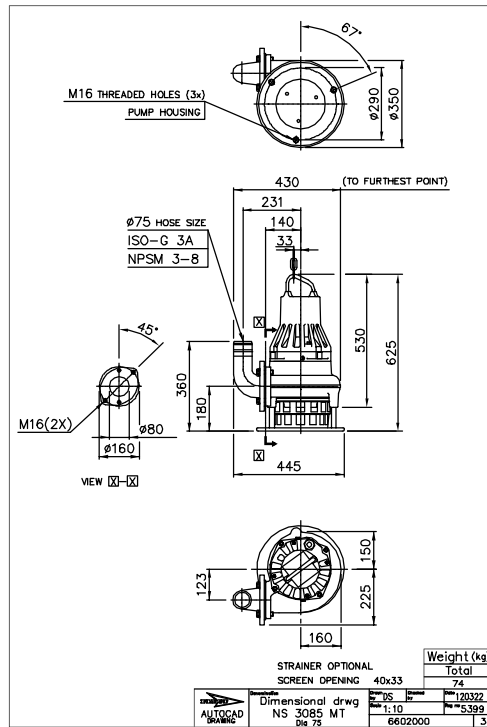

Figure 34: MT, S-installation

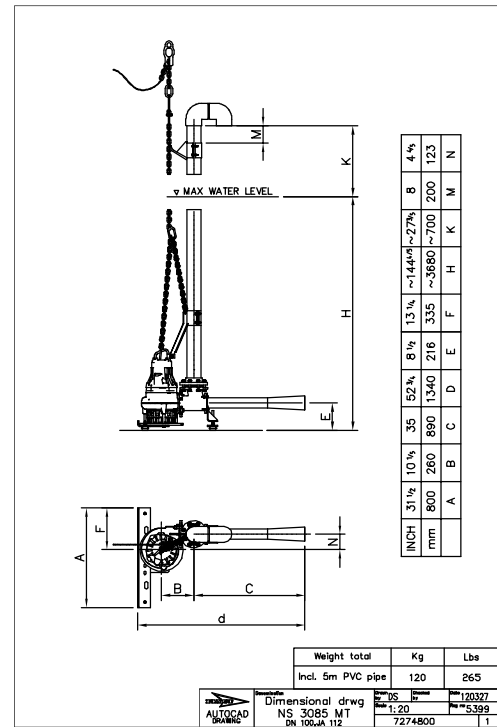

Figure 35: MT, S-installation

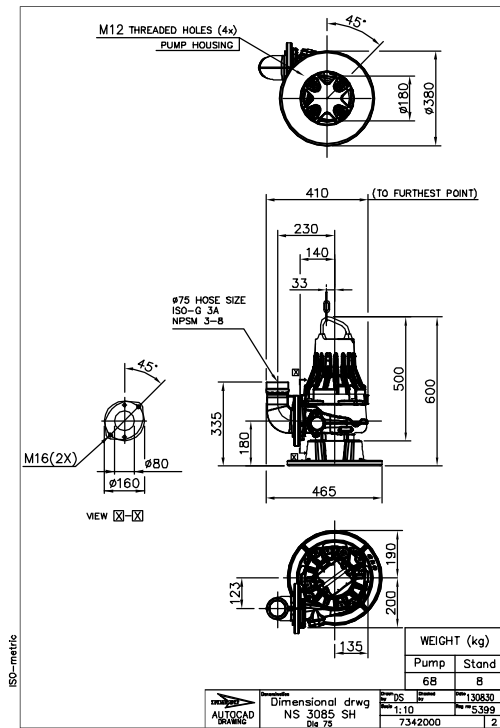

Figure 40: SH, S-installation

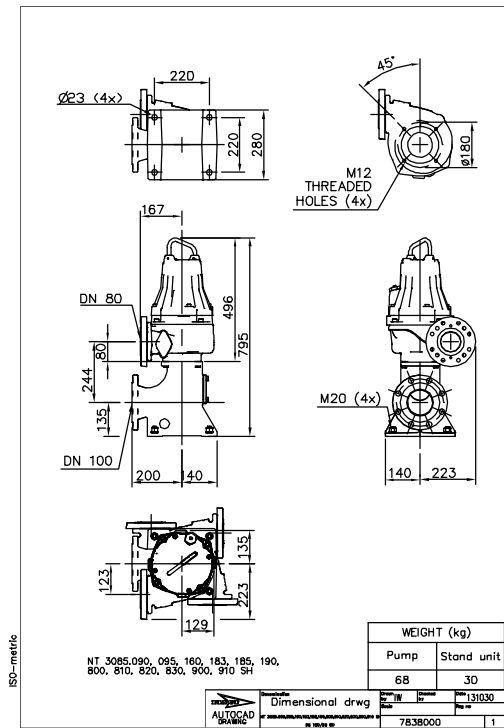

Figure 41: SH, T-installation

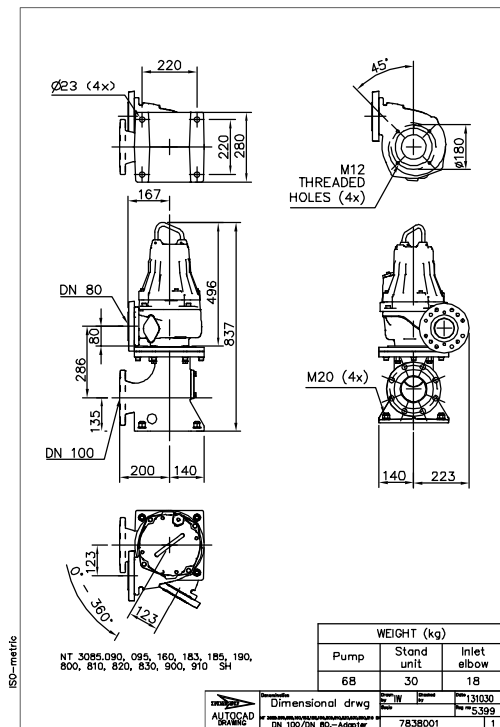

Figure 42: SH, T-installation

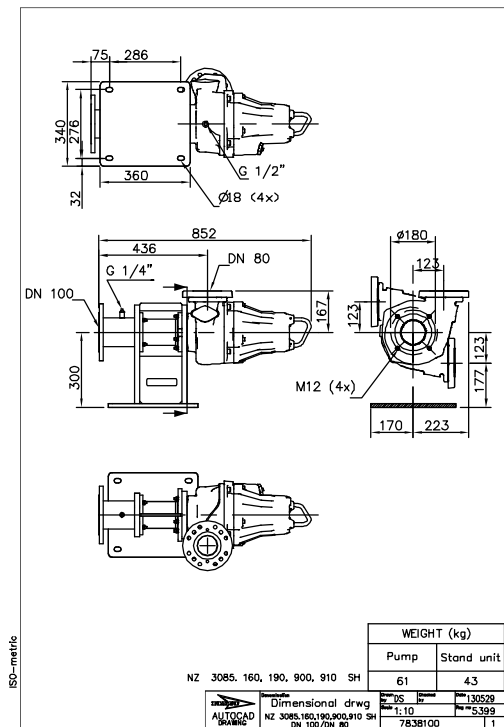

Figure 43: SH, Z-installation

Xylem |'zīləm|

- 1) The tissue in plants that brings water upward from the roots
- 2) A leading global water technology company

We're 12,900 people unified in a common purpose: creating innovative solutions to meet our world's water needs. Developing new technologies that will improve the way water is used, conserved, and re-used in the future is central to our work. We move, treat, analyze, and return water to the environment, and we help people use water efficiently, in their homes, buildings, factories and farms. In more than 150 countries, we have strong, long-standing relationships with customers who know us for our powerful combination of leading product brands and applications expertise, backed by a legacy of innovation.

For more information on how Xylem can help you, go to xylem.com



Xylem Water Solutions
Manufacturing AB
361 80 Emmaboda
Sweden
Tel: +46-471-24 70 00
Fax: +46-471-24 47 01
<http://tpi.xylem.com>

Visit our Web site for the latest version of this document and more information

The original instruction is in English. All non-English instructions are translations of the original instruction.

© 2012 Xylem Inc