

Xylem Water Solutions AB (the Company) was previously named ITT Water & Wastewater AB. The name change took place in November 2011. This is document is (i) a document that relates to a product of the Company phased out prior to the name change; or (ii) an old version of documentation relating to a product that is still being produced by the Company but which document was published prior to the 1st of January 2012 . This document may therefore still be marked "ITT". Xylem Water Solutions AB is no longer an ITT company and the fact that "ITT" may appear on this document shall not be interpreted as a reference by the Company to "ITT" in the Company's current business activities. Any use or reference to "ITT" by you is strictly prohibited. In no event will we be liable for any incidental, indirect, consequential, punitive or special damages of any kind, or any other damages whatsoever, including, without limitation, those resulting from loss of profit, loss of contracts, loss of reputation, goodwill, data, information, income, anticipated savings or business relationships for any use by you of "ITT". This disclaimer notice shall be interpreted and governed by Swedish law, and any disputes in relation to it are subject to the jurisdiction of the courts in Sweden. If you do not agree to these terms and conditions you should not print this document and immediately stop accessing it.



End of Disclaimer text.

C 3170.180



Technical specification

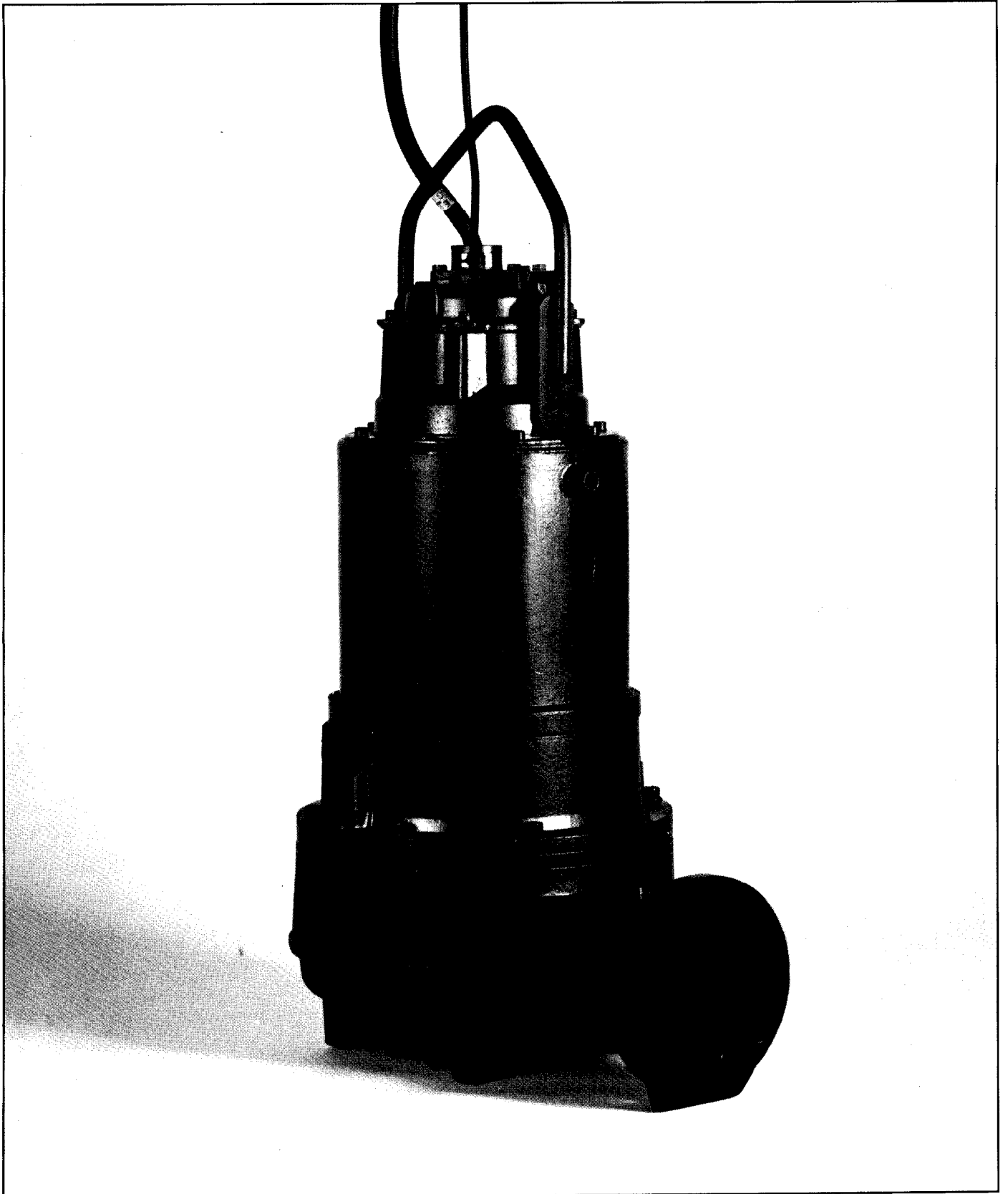

3170.180 Technical specification

The Flygt 3170.180 submersible pump with a capacity of up to 300 l/s covers a number of areas of application.

The electric motor and the pump comprise a compact and robust unit which requires little space and is easy to handle.

The pump is designed to handle liquid containing solid particles such as waste water. It can also be used for pumping clean or raw water.

The pump casing and the one- and two-vane impellers can pass solids of diameters up to 102 mm. (See impeller throughlet for details).

INSTALLATION ALTERNATIVES

The pump is submersible, compact and easy to install. The different versions are available in one or more models, depending upon the type of installation.

CP

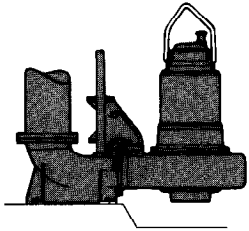

This system with guide bars and discharge connection permits automatic connection of the pump to the discharge line. The pump can be removed for inspection without anyone having to enter the sump.

The pump will work completely or partially submerged in the liquid being pumped.

CT

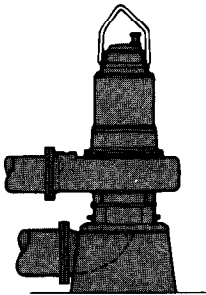

The pump is installed dry on a base stand and is connected directly to the inlet and outlet lines. The submersible design of the pump prevents damage to the electric motor should the dry well or pump room be flooded.

CS

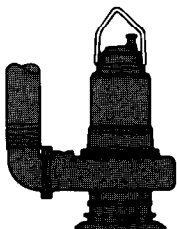

A portable pump intended for operating completely or partially submerged in the pumped liquid. It is equipped with base stand and discharge hose connection.

Different versions of the hydraulic section

Depending on desired performance, the pump is available in low-, medium- and high-head models.

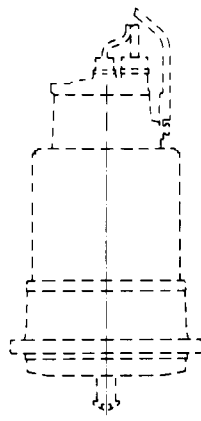

		Impeller		
		Curve No.	Number of Vanes	Through-let, mm
LT low-head model for CP, CT and CS installation		601	2	Elliptical 102 × 102
		602	2	102 × 102
		603	2	102 × 102
		604	2	102 × 102
MT medium-head model for CP, CT and CS installation		440	1	Circular Ø 100
		441	1	Ø 100
HT high-head model for CP, CT and CS installation.		460	1	Circular 77 × 80
		461	1	77 × 80
		462	1	77 × 77

TECHNICAL DATA

Pump type	Motor: Squirrel-cage, 3-phase AC motor Insulation class F, 50 Hz							Power cable*			
	Rated power	Speed	Rated current					Direct on-line start		Star-delta start	
			kW	rev/min	220 V	380 V	415 V	500 V	660 V	220 V	380—660 V
C-version CP, CT, CS 3170 LT	15	970	58 A	34 A	31 A	26 A	19 A	4 × 25 mm ²	4 × 10 mm ²	2 × 4 × 10 mm ²	7 × 6 + 2 × 1.5 mm ²
C-version CP, CT, CS 3170 MT, HT	22	1455	75 A	44 A	40 A	33 A	25 A	4 × 25 mm ²	4 × 10 mm ²	2 × 4 × 10 mm ²	7 × 6 + 2 × 1.5 mm ²

* For details of local cable requirements, contact your local Flygt agent.

Weights in kg

Pump type	With cooling	Without cooling	Discharge connection
C version			
CP 3170 LT	565	540	210
CP 3170 MT	520	500	65
CP 3170 HT	475	455	35
CT 3170 LT	660	—	incl. inlet
CT 3170 MT	570	—	bend and
CT 3170 HT	510	—	base stand
CS 3170 LT	600	580	incl. hose
CS 3170 MT	530	510	conn. and
CS 3170 HT	475	455	base stand

Materials

		BS	DIN
Cast parts:	Cast iron	1452	1691
		Grade 220	GG20
Shaft:	Carbon steel	970	17200 C35
		080M36	
Studs, nuts, screws and bolts:	Stainless steel	EN58A	17440
			X5CrNi 18/9
Lifting handle:	Galvanized steel	4360	17100 RST 37-2
			Grade 40B
O-rings:	Nitrile rubber (70° IRH)		
Stationary wear ring:	Nitrile-rubber-clad steel or brass	1400LG2	1705Rg5
Rotating wear ring:	Stainless steel	EN 58A	17440
			X5CrNi 18/9
Mechanical shaft seals, upper:	Carbon/tungsten carbide		
lower:	Tungsten carbide/tungsten carbide		

Surface treatment

Impeller:	Sprayed with primer
Pump's outer casing:	The pump's outer casing is primed with PVC Epoxy and painted with black chloric rubber paint.

PERFORMANCE CURVES

Each pump is tested in accordance with International Standard ISO 2548, Class C.

□ = Optimum operating point

LT Curve No. 601, 602, 603, 604

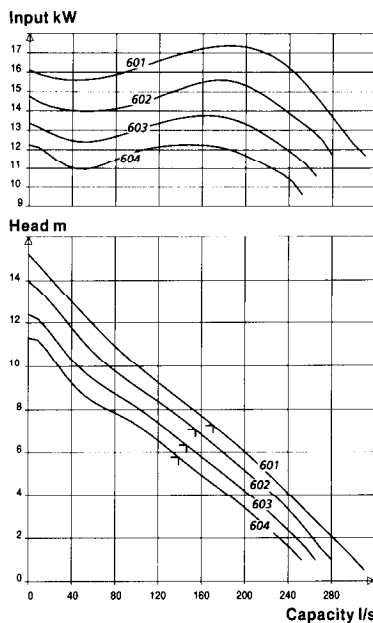

MT Curve No. 440, 441

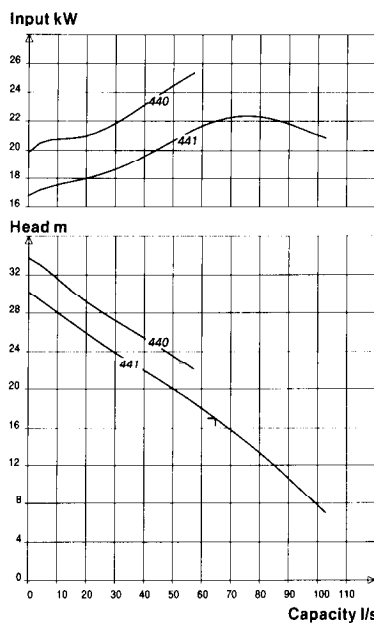

HT Curve No. 460, 461, 462

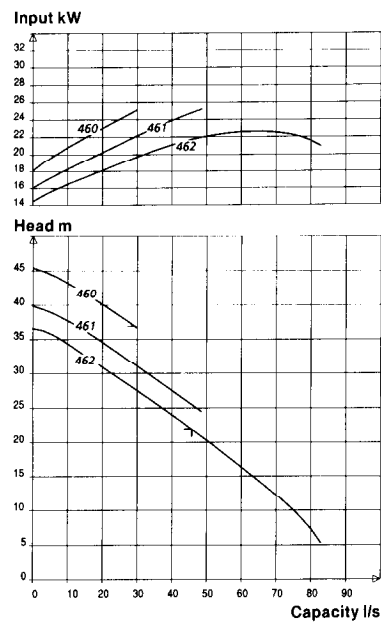

- The 3170 in its standard version can pump liquids at temperatures of up to 40°C (105°F).
- The pump can be submerged down to 20 m below the surface.
- The pump section, including seals and cooling jacket, is designed for working pressures of up to 0.9 MPa.
- The motors are designed to supply their rated outputs at deviations of up to ±5% of the rated frequency and voltage. Deviations of up to ±10% of the rated voltage can be tolerated without overheating.
- The 3170 can be started up (equally divided starts) to 15 times per hour.
- Starting methods: Direct on-line start or star-delta start.
- Service and maintenance are dependent upon operating conditions and are specified in the care and maintenance instructions.
- The 3170 is available in 60 Hz.

DESIGN

1. Junction box

The junction box is completely sealed off from the surrounding liquid.

2. Cooling

A built-in cooling system enables the pump to work continuously at its rated output regardless of whether the electric motor is above or below the surface of the liquid.

A portion of the pumped liquid is circulated from the pump casing up between the cooling jacket and the stator casing and carries away the heat generated by the motor.

Where external cooling is required, the cooling jacket can be sealed off from the pump casing and connected to a separate cooling system.

3. Motor

Flygt motors are tested according to IEC 34-1.

Motor insulation to class F means a maximum working temperature of 155°C (310°F) and permits a temperature rise of 100°C (210°F).

The temperature rise in Flygt motors does not normally exceed 80°C (175°F). The insulation material is chosen with the greatest care, and most materials are classified as Class H (180°C, 355°F) materials or very close to Class H. This means an expected service life far beyond what is required for Class F.

4. Bearings

The upper bearing consists of a roller bearing and the lower bearing is a two-row angular contact ball bearing.

5. Shaft seals

3170.180 has two mechanical seals.

The seals work independently of each other and seal off the motor from the pump section casing.

6. Shaft

The common pump/motor shaft does not come into contact with the pumped liquid.

7. Oil casing

The oil lubricates and cools the seals and acts as a buffer between the pumped liquid and the electric motor.

Pressure build-up within the oil casing is reduced by means of a built-in air volume.

8. Impellers

The pump is available with the following types of impellers: single-vane impeller or two-vane impeller.

9. Wear rings

The pump casing bottom and the impeller are equipped with easily replaceable wear rings.

Monitoring system

The stator incorporates three thermal switches connected in series.

The thermal switches open at 125°C (255°F).

3170.180 can be obtained with built-in leakage sensors for detection of water in the oil- or stator-casing.

Special executions

This size pump is available in special executions for:

- explosive environments approved according to FM and EN.
- the pump is also available in a version for liquid temperatures up to 90°C (195°F).

Contact your local Flygt representative.

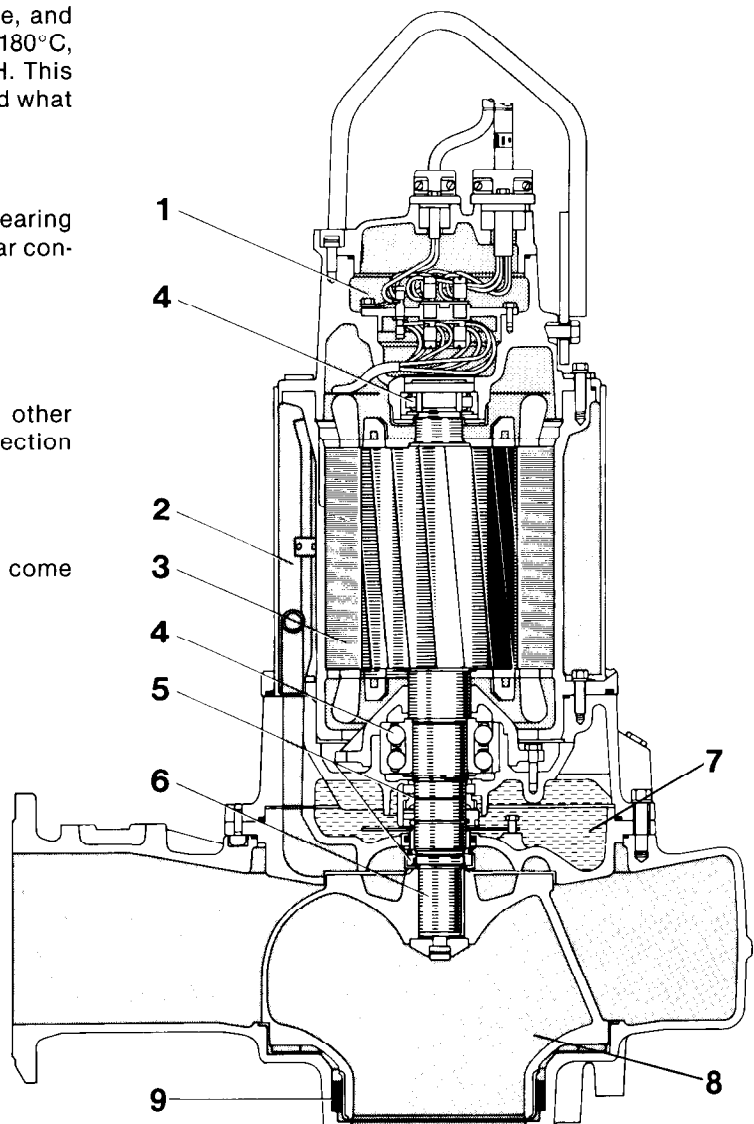

DIMENSIONS

All dimensions are in mm.

CP

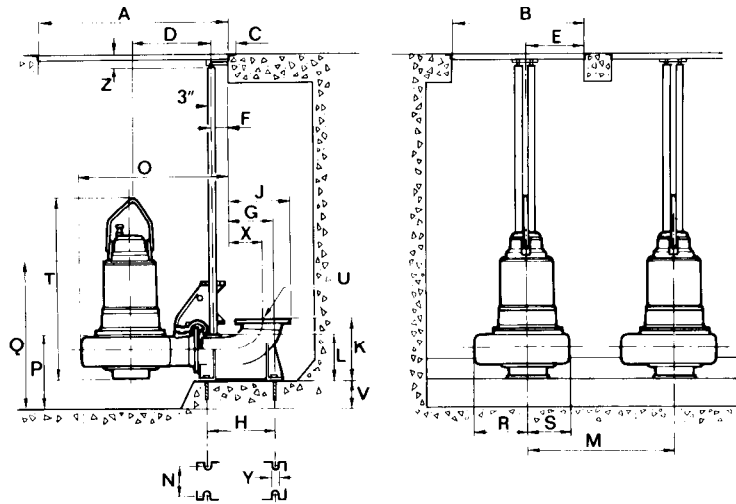

CP version	A	B	C	D	E	F	G	H	J	K	L	Min. M dim.
LT Ø300	1200	850	50	591	425	135	194	500	540	800	638	900
LT Ø250	1200	850	50	591	425	135	309	500	427	450	363	900
MT Ø200	1200	850	50	541	425	135	89	280	344	450	346	750
MT Ø150	1200	850	50	541	425	135	59	280	289	450	332	750
HT Ø150	1200	850	50	541	425	135	59	280	289	450	332	750
HT Ø100	1200	850	50	541	425	135	19	250	224	400	260	750

CP version	N	O	P	Q	R	S	T	U*	Min. V dim.	X	Y	Z
LT Ø300	470	1105	665	1210	410	295	1350	Ø300	—	300	23	130
LT Ø250	210	1105	590	1135	410	295	1350	Ø250	200	225	23	130
MT Ø200	210	970	505	1045	285	255	1305	Ø200	100	175	23	130
MT Ø150	210	970	495	1040	285	255	1305	Ø150	100	145	23	130
HT Ø150	210	970	495	1040	285	255	1275	Ø150	100	145	23	130
HT Ø100	160	970	470	1015	285	255	1275	Ø100	150	115	23	130

CT

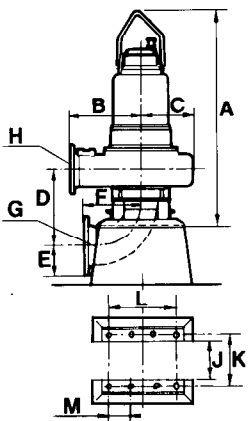

CT version	A	B	C	D	E	F
LT	1520	500	355	565	240	400
MT	1505	450	270	490	175	450
HT Ø200	1475	450	270	490	175	450
HT Ø150	1475	450	270	435	142	320

CT version	G*	H*	J	K	L	M
LT	Ø300	Ø250	376	470	500	250
MT	Ø200	Ø150	376	470	500	250
HT Ø200	Ø200	Ø100	376	470	500	250
HT Ø150	Ø150	Ø100	376	470	500	250

CS

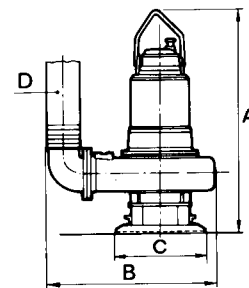

CS version	A	B	C	D
LT Ø250	1520	1175	600	Ø250
LT Ø200	1520	1150	600	Ø200
MT Ø200	1505	985	600	Ø200
MT Ø150	1505	935	600	Ø150
MT Ø100	1505	895	600	Ø100
HT	1475	860	600	Ø100

* Flange connection drilled to BS 4622: 1970 table 11 or DIN 2532

