

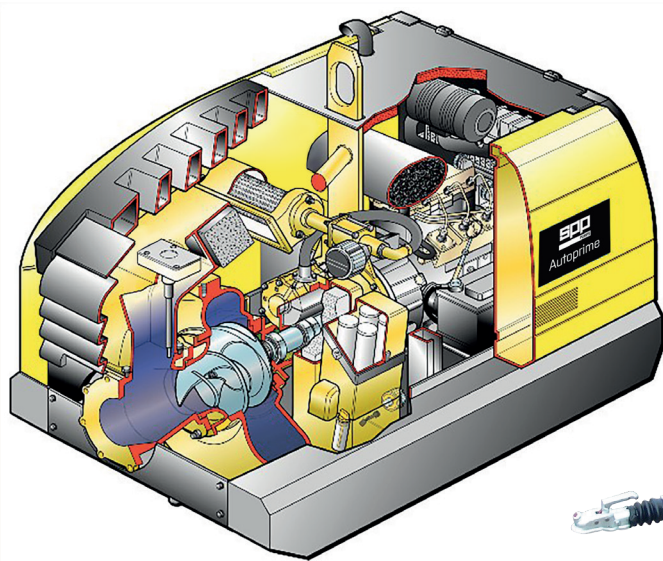

DEWATERING AUTOPRIME DATA SHEET

QHH80 - 80MM HIGH HEAD AUTOMATIC PRIMING PUMP

The SPP Autoprime QHH80 Pump is designed for high head and modest flow applications including jetting, washing and in mines and quarries where a high lift is required. Solids handling is limited by the use of a high performance design for the impeller.



STAGE
COMPATIBLE



DESIGN FEATURES

- Bunded unit on two wheel road trailer with fixed height towing eye or 50mm ball hitch.
- Alternative trailer for the QHH80 with variable height draw available (adds 35kg to weight).
- 12 volt battery starting by key switch.
- Pump will pass solids up to 20mm diameter.
- Reliable double mechanical seals which allow dry running.
- Pump can be left running when liquid is exhausted and will prime automatically when liquid is present.
- Rugged construction requires minimal operator maintenance.
- 65 cfm Vacuum Pump with coalescer and air filtered before exhaust to atmosphere.
- Glycerin filled vacuum pressure gauge located externally for visual inspection of vacuum.
- Emergency stop button.

DEWATERING AUTOPRIME DATA SHEET

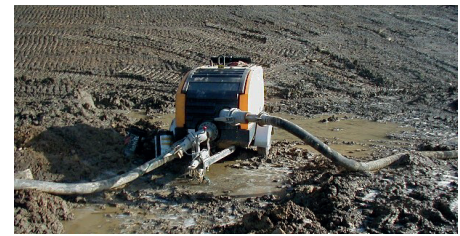

PUMP SPECIFICATIONS

FLOW RATE

430 m³/h Maximum

DISCHARGE HEAD

37m Maximum

WORKING PRESSURE

10 bar Maximum

SUCTION HOSE SIZE

200 mm (8") Dia.

DISCHARGE HOSE SIZE

150 mm (6") Dia.

MAX SOLIDS SIZE

65 mm Diameter x 80 mm

PUMP CASING / SUMP

Cast Iron

IMPELLER

SG Iron

PUMP SHAFT

Stainless Steel

WEAR PLATES

SG Iron

SHAFT SEAL

Silicon Carbide/Silicon Carbide

ELASTOMER

Viton

DIESEL ENGINE

Perkins 404D/Yanmar 4TNV88 - Stage IIIA/Tier 3

Yanmar 4TNV88c - Stage V

STARTING

12 Volt Battery

SOUND PRESSURE LEVEL

65 db(A) at 7 metres

FUEL TANK CAPACITY

220 litres

FULL LOAD RUNNING TIME

24 hours

CHASSIS OPTIONS

Road Trailer or Skid Base

WEIGHT -GROSS

Up to 1500kg

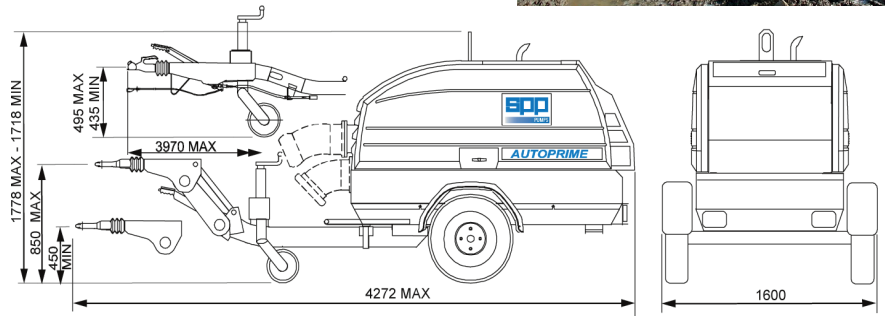

AUTOPRIME
QHH80 - 328

Curve Ref: QHH80 328
Speed: see below (rpm)
Suct x Disch: 100 x 80 mm

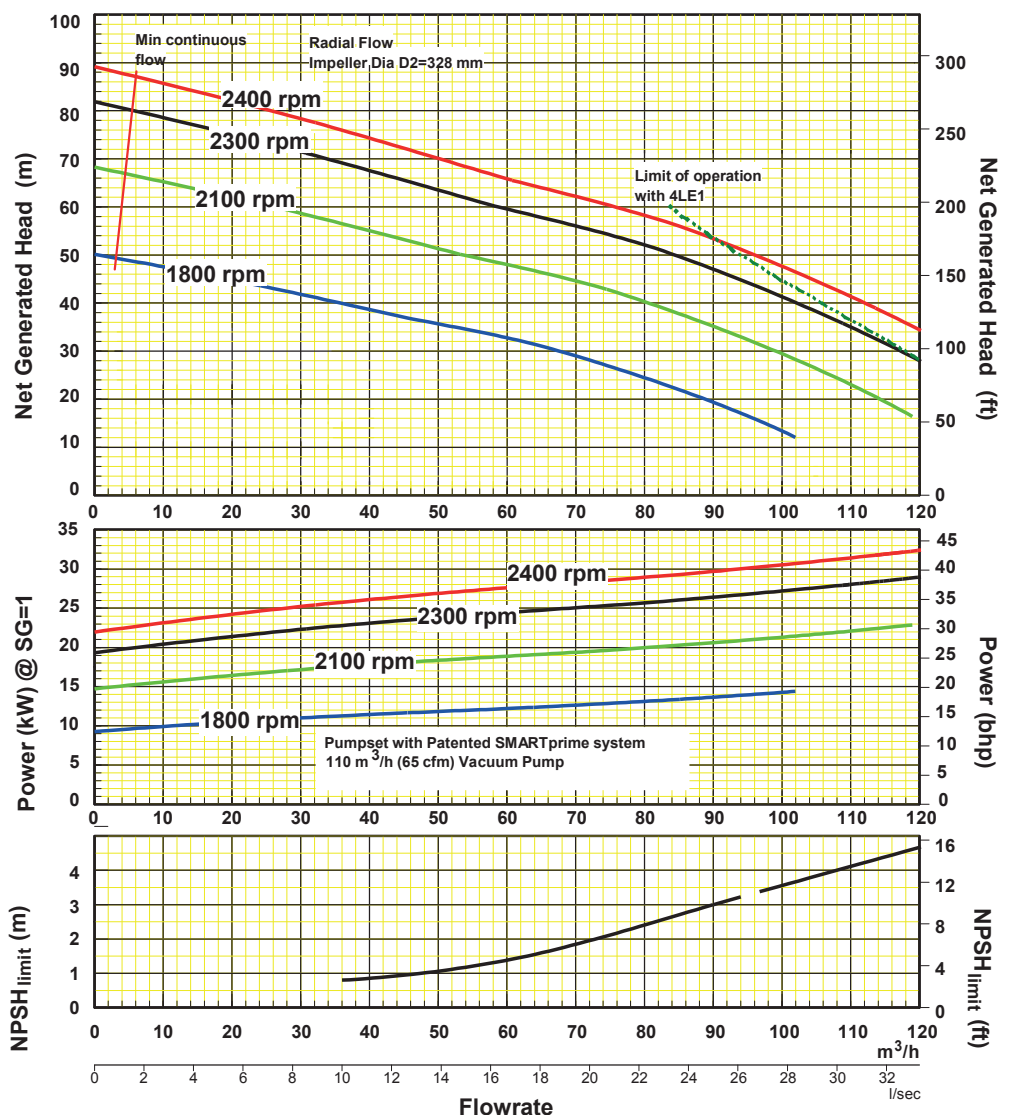

OPTIONAL EXTRAS

- Auto/stop start control panel – float operation.
- Pump Telemetry.
- Spark arrestor and Chalwyn valve.
- Battery isolator.
- Fuel valve for auxiliary fuel tanks.
- Optional door colour to suit customer branding.
- Emergency trailer with pipe and fittings.
- Training.
- Hose/pipework.
- Service & Maintenance package.
- Spares kit.