

HL225M Dri-Prime® Pump

The Godwin Dri-Prime HL225M pump is an extremely powerful yet compact pump with flow capabilities to 832 m³/hr and discharge heads to 113 metres.

The HL225M features the unique Godwin high pressure oil bath mechanical seal design. This allows for dry running for prolonged periods while automatically priming and repriming. Able to perform in the toughest conditions, the HL225M can handle solids up to 65 mm in diameter. This makes it an extremely effective pump, suitable for both slurry and clean water applications. The powerful HL225M has proven itself a pump of choice for mines, quarries and many other high capacity applications.



Features and Benefits

- Fully automatic priming from dry to 8.5 metres suction lift.
- Godwin Dri-Prime is a continuously operated Venturi air ejector priming device which requires no periodic adjustment or control.
- Extensive application flexibility. It will handle sewage, slurries and liquids with solids up to 65 mm in diameter.
- Dry-running high pressure oil bath mechanical seal, with high abrasion resistant silicon carbide faces.
- A Close-coupled centrifugal pump with Godwin Dri-Prime system mounted to a diesel engine or electric drive.
- All cast iron construction (stainless steel construction option available) with cast steel impeller.
- Also available as Hush-Pac or as a bareshaft pumpend.
- Standard build engines; Caterpillar C15, Caterpillar C9, Volvo TAD951VE, Volvo TAD952VE. Other engine options are available.

Specifications

Suction connection	250 mm (10" BS10 Table 'D')
Delivery connection	200 mm (8" BS EN 1092 PN16)
Max capacity	832 m ³ /hr
Max Head	113 metres
Max Solids handling	65 mm
Max Impeller diameter	440 mm
Max operating temp	80 °C
Max working pressure	11.3 bar
Max suction pressure	6.0 bar
Max casing pressure	16.9 bar
Max operating speed	2000 rpm

godwin 
a xylem brand

Performance Curve

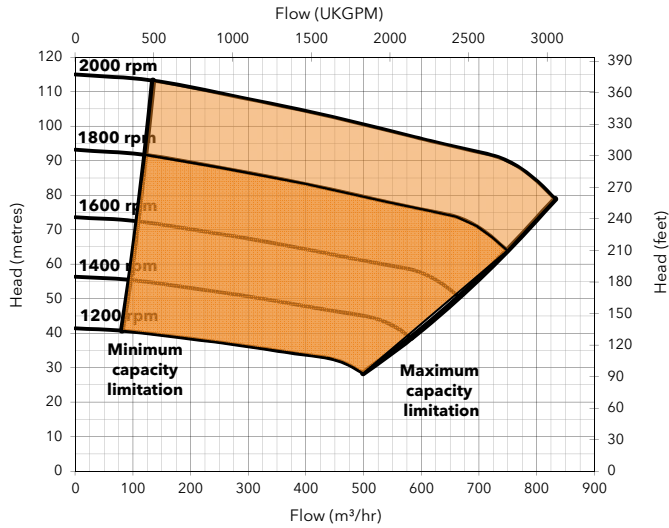

Engine option 1

Price list ref - HL225M-01-DBO-002

Caterpillar, C15, 315.0 kW @ 2000 rpm

Impeller diameter 440 mm

Pump Speed 2000 rpm

Suction Lift Table

Total Suction Head (metres)	Total Delivery Head (metres)				
	75	87	93	99	106
	Output (m³/hr)				
3.0	839	744	611	444	278
4.6	833	722	567	360	222
6.1	611	583	533	356	178
7.6	472	433	389	278	-

Fuel capacity (Full) 1225 litres, (Usable) 993 litres

Fuel consumption @ 2000 rpm BEP 71 litres/hour

Weight: (Dry) 5,740 kg, (Wet) 6,900 kg

Dimensions: (L) 4,000 x (W) 1,950 x (H) 2,350 mm

Performance data provided in tables is based on water tests at sea level and 20°C ambient. All information is approximate and for general guidance only. Please contact the factory or office for further details.

Materials

Pump casing & suction cover	Cast iron BS EN 1561 - 1997
Wearplates	Cast Iron BS EN 1561 - 1997
Pump Shaft	Carbon steel BS EN 1561 - 1997
Impeller	Cast Steel BS3100 A5 Hardness to 200 HB Brinell
Non-return Valve body	Cast Iron BS EN 1561 - 1997
Mechanical Seal Faces	Silicon carbide vs silicon carbide

Engine option 2

Price list ref - HL225M-01-DBO-001

Caterpillar, C9, 205.0 kW @ 1800 rpm

Impeller diameter 440 mm

Pump Speed 1800 rpm

Suction Lift Table

Total Suction Head (metres)	Total Delivery Head (metres)				
	60	70	75	80	85
	Output (m³/hr)				
3.0	755	670	550	400	250
4.6	750	650	510	324	200
6.1	550	525	480	320	160
7.6	425	390	350	250	-

Fuel capacity (Full) 850 litres, (Usable) 690 litres

Fuel consumption @ 1800 rpm BEP 49 litres/hour

Weight: (Dry) 4,500 kg, (Wet) 5,231 kg

Dimensions: (L) 3,700 x (W) 1,700 x (H) 2,200 mm

Performance data provided in tables is based on water tests at sea level and 20°C ambient. All information is approximate and for general guidance only. Please contact the factory or office for further details.

HL225M - Caterpillar C9

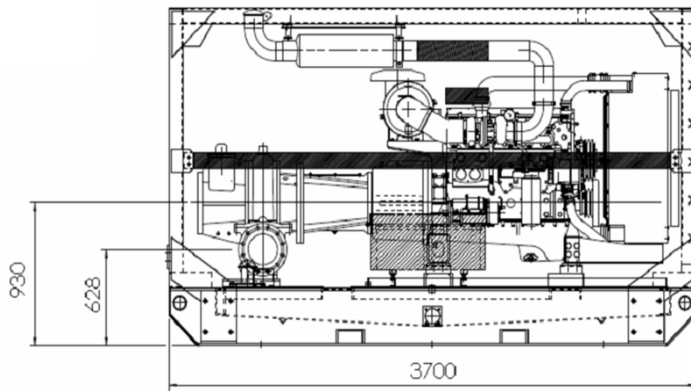
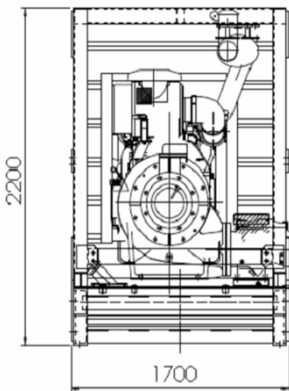

Xylem Dewatering Solutions UK Ltd
 Quenington, Cirencester
 Gloucestershire GL7 5BX, England
 Tel: 01285 750271 Fax: 01285 750352



Assessed to ISO 9001:2008
 Certificate N° 1027

Reference number : 95-1113-1000
 Date of issue : 05 December 2012
 Issue : 10

www.godwinpumps.com