

HL100M Dri-Prime® Pump

The Godwin Dri-Prime HL100M pump is an extremely powerful yet compact pump with flow capabilities to 210 m³/hr and discharge heads to 115 metres.

The HL100M features the unique Godwin high pressure oil bath mechanical seal design. This allows for dry running for prolonged periods while automatically priming and repriming. Able to perform in the toughest conditions, the HL100M can handle solids up to 35 mm in diameter. This makes it an extremely effective pump, suitable for both slurry and clean water applications. The powerful HL100M has proven itself a pump of choice for sewage handling, dewatering, local authority usage and many other applications.



Features and Benefits

- Fully automatic priming from dry to 8.5 metres suction lift.
- Godwin Dri-Prime is a continuously operated Venturi air ejector priming device which requires no periodic adjustment or control.
- Extensive application flexibility. It will handle sewage, slurries and liquids with solids up to 35 mm in diameter.
- Dry-running high pressure oil bath mechanical seal, with high abrasion resistant silicon carbide faces.
- A Close-coupled centrifugal pump with Godwin Dri-Prime system mounted to a diesel engine or electric drive.
- All cast iron construction (stainless steel construction option available) with cast steel impeller.
- Also available as Hush-Pac or as a bareshaft pumpend.
- Standard build engines; Perkins 1104D-E44TA, Perkins 1104D-44TA. Other engine options are available.

Specifications

Suction connection	100 mm (4" BS10 table 'D')
Delivery connection	100 mm (4" BS EN 1092 PN16)
Max capacity	210 m ³ /hr
Max Head	115 metres
Max Solids handling	35 mm
Max Impeller diameter	370 mm
Max operating temp	80 °C
Max working pressure	11.4 bar
Max suction pressure	6.0 bar
Max casing pressure	17.1 bar
Max operating speed	2200 rpm

godwin 
a xylem brand

Performance Curve

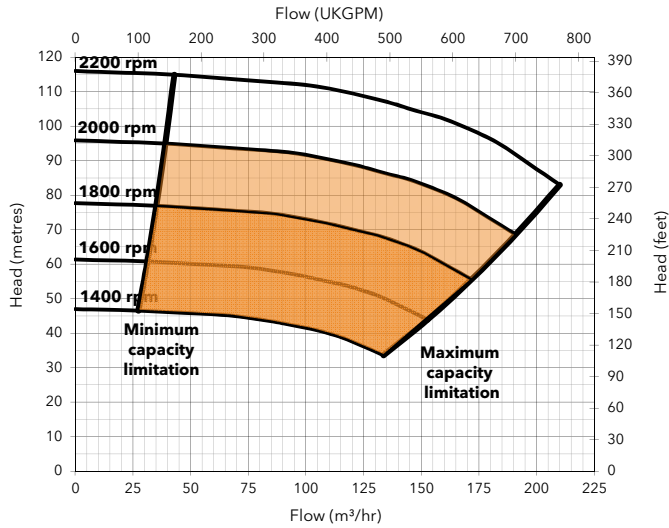

Engine option 1

Price list ref - HL100M-01-DBO-002

Perkins, 1104D-E44TA, 74.1 kW @ 2000 rpm

Impeller diameter 370 mm

Pump Speed 2000 rpm

Suction Lift Table

Total Suction Head (metres)	Total Delivery Head (metres)				
	65	75	80	85	88
3.0	191	166	152	130	100
4.6	185	165	145	122	90
6.1	175	155	135	115	65
7.6	165	150	120	100	35

Fuel capacity (Full) 390 litres, (Usable) 318 litres

Fuel consumption @ 2000 rpm BEP 17 litres/hour

Weight: (Dry) 1,867 kg, (Wet) 2,200 kg

Dimensions: (L) 2,500 x (W) 1,300 x (H) 1,900 mm

Performance data provided in tables is based on water tests at sea level and 20°C ambient. All information is approximate and for general guidance only. Please contact the factory or office for further details.

Materials

Pump casing & suction cover	Cast iron BS EN 1561 - 1997
Wearplates	Cast iron BS EN 1561 - 1997
Pump Shaft	Carbon steel BS EN 1561 - 1997
Impeller	Cast Steel BS3100 A5 Hardness to 200 HB Brinell
Non-return Valve body	Cast Iron BS EN 1561 - 1997
Mechanical Seal Faces	Silicon carbide vs silicon carbide

Engine option 2

Price list ref - HL100M-01-DBO-001

Perkins, 1104D-44TA, 60.5 kW @ 1800 rpm

Impeller diameter 370 mm

Pump Speed 1800 rpm

Suction Lift Table

Total Suction Head (metres)	Total Delivery Head (metres)				
	50	58	62	66	69
3.0	172	149	137	117	90
4.6	167	149	131	110	81
6.1	158	140	122	104	59
7.6	149	135	108	90	32

Fuel capacity (Full) 390 litres, (Usable) 318 litres

Fuel consumption @ 1800 rpm BEP 15 litres/hour

Weight: (Dry) 1,944 kg, (Wet) 2,275 kg

Dimensions: (L) 2,500 x (W) 1,300 x (H) 1,900 mm

Performance data provided in tables is based on water tests at sea level and 20°C ambient. All information is approximate and for general guidance only. Please contact the factory or office for further details.

HL100M - Perkins 1104D-E44TA

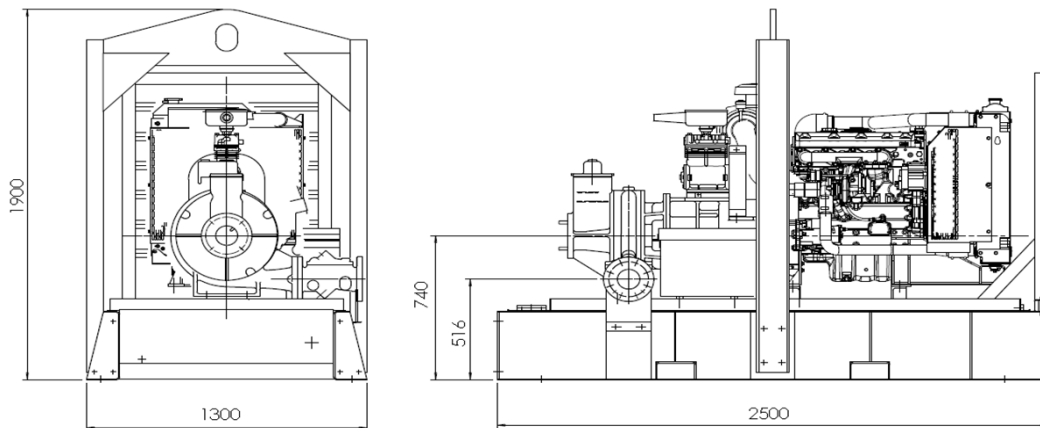

Xylem Dewatering Solutions UK Ltd
 Quenington, Cirencester
 Gloucestershire GL7 5BX, England
 Tel: 01285 750271 Fax: 01285 750352



Assessed to ISO 9001:2008
 Certificate N° 1027

Reference number : 95-1109-1000
 Date of issue : 05 December 2012
 Issue : 9

www.godwinpumps.com