

STUART PUMPS LTD

Wear resistant pumps with agitator

TECHNICAL SPECIFICATIONS

TECHNICAL CHARACTERISTIQUES

Performance curves

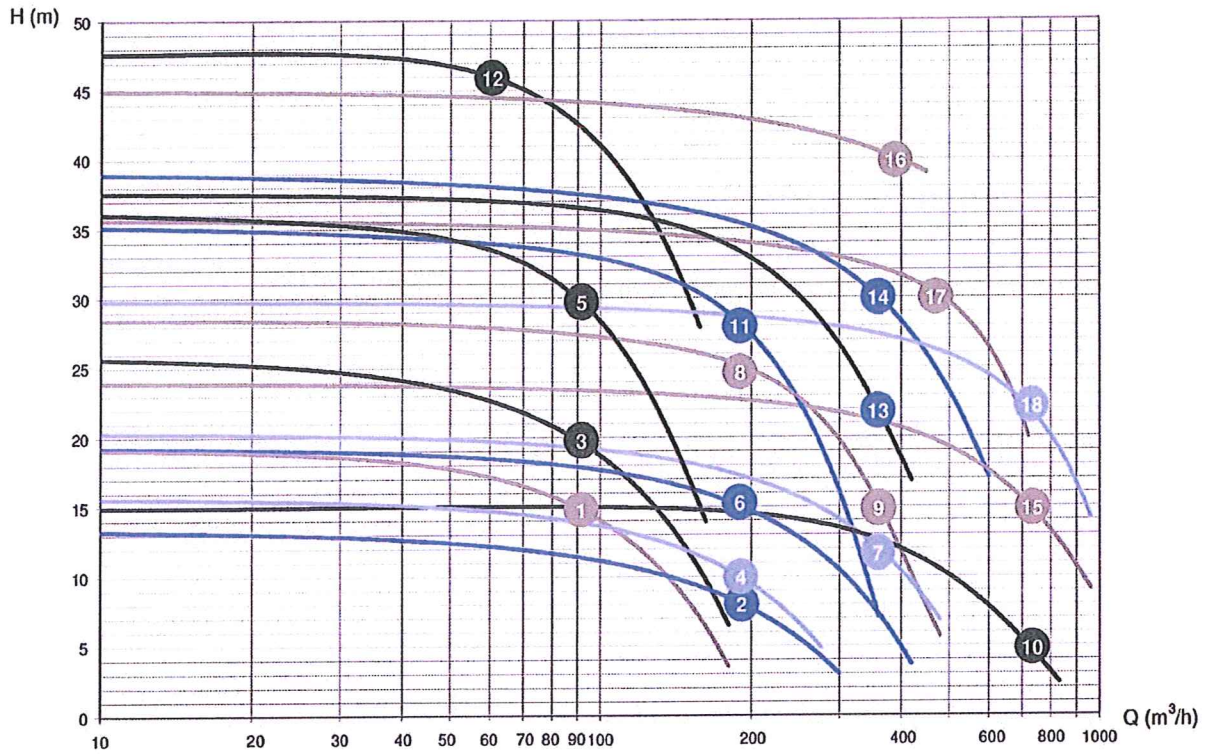

Nr	Type	Outlet (inch)(mm)	Capacity (m ³ /h)	Manom. head (m)	Particle size (mm)	Power (kW)	Revolution (1/min) 50Hz	Current (A) 400 V	Electr. cable	Weight (kg)
1	DP15 - 4	4 100	90	15	35	11	960	24	4X10mm ²	490
2	DP15B - 6	6 150	192	8	60	11	960	24	4X10mm ²	530
3	DP20 - 4	4 100	90	20	35	15	970	32	4X10mm ²	550
4	DP20B - 6	6 150	192	10	60	15	970	32	4X10mm ²	540
5	DP30 - 4	4 100	90	30	35	22	975	46	4X16mm ²	750
6	DP30B - 6	6 150	192	15	60	22	975	46	4X16mm ²	730
7	DP40B - 8	8 200	360	12	40	30	970	58	4X35mm ²	750
8	DP50 - 6	6 150	192	25	60	37	980	75	4X35mm ²	950
9	DP50B - 8	8 200	360	15	60	37	980	75	4X35mm ²	970
10	DP50BL - 10	10 250	720	5	100	37	980	75	4X35mm ²	1150
11	DP50H - 6	6 150	192	28	40	37	980	75	4X35mm ²	1050
12	DPS50S - 4	4 100	60	46	15	37	1775	61	4x35mm ²	730
13	DP75B - 8	8 200	360	22	40	55	975	116	4X50mm ²	1120
14	DP100B - 8	8 200	360	30	60	75	740	150	4X50mm ²	2200
15	DP100BL-10	10 250	720	15	100	75	740	150	4X50mm ²	2700
16	DP150 - 8	8 200	390	40	120	110	590	215	4X95mm ²	3500
17	DP150L - 8	8 200	480	30	120	110	590	215	4X95mm ²	3500
18	DP150B - 10	10 250	720	22	120	110	590	215	4X95mm ²	3500

DIMENSIONS

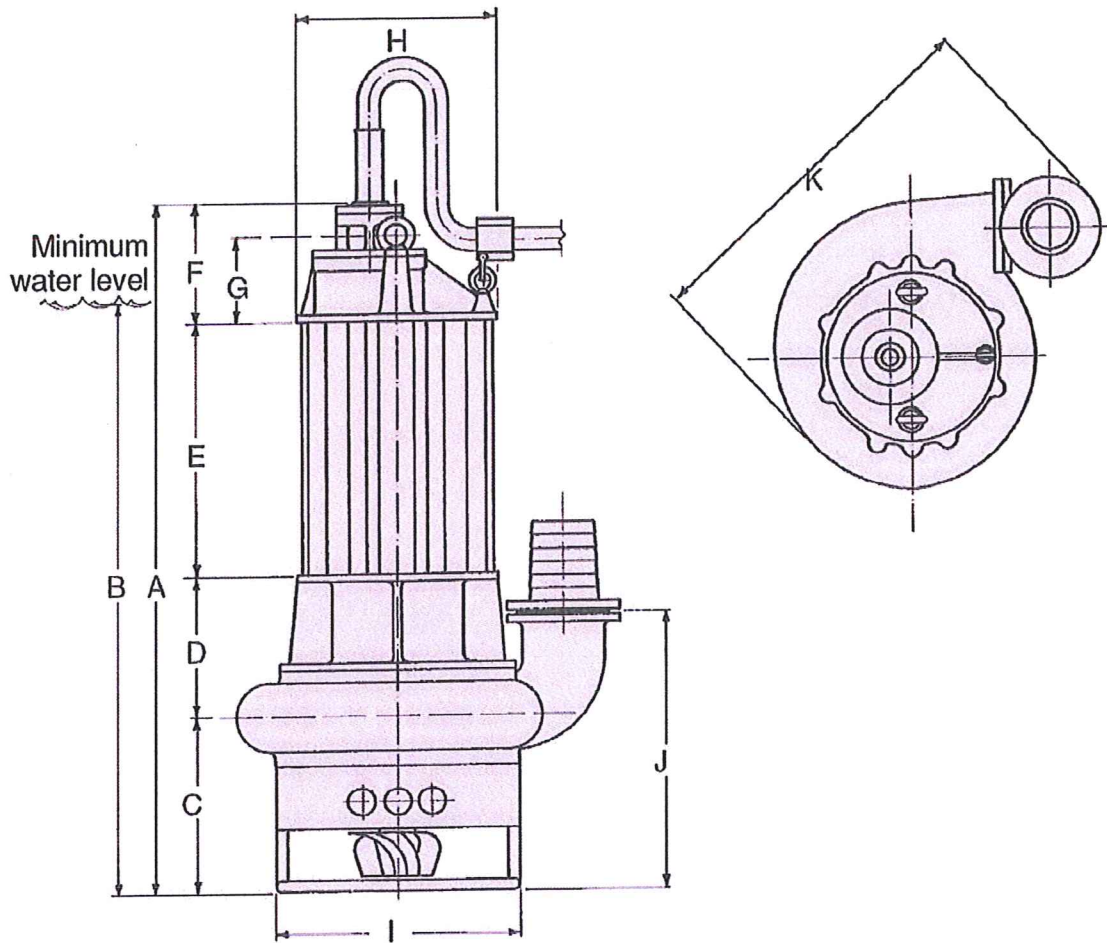

DIMENSIONS	A	B	C	D	E	F	G	H	I	J	K
1 DP15 - 4	1275	1100	350	260	425	240	155	380	445	500	750
2 DP15B - 6	1275	1100	330	280	425	240	155	380	445	560	841
3 DP20 - 4	1310	1100	345	265	460	240	155	380	515	495	825
4 DP20B - 6	1310	1100	330	280	460	240	155	380	445	560	841
5 DP30 - 4	1390	1200	365	280	480	265	195	415	635	515	910
6 DP30B - 6	1390	1200	350	295	480	265	195	415	510	580	955
7 DP40B - 8	1390	1200	350	295	480	265	195	415	510	600	1010
8 DP50 - 6	1575	1350	405	325	570	275	195	460	560	635	1020
9 DP50B - 8	1575	1350	405	325	570	275	195	460	560	655	1065
10 DP50BL - 10	1650	1450	462.5	342.5	570	275	195	460	560	762.5	1350
11 DP50H - 6	1580	1350	420	315	570	275	195	460	660	650	1094
12 DPS50S - 4	1420	1200	345	280	530	265	195	415	515	498	825
13 DP75B - 8	1670	1450	420	315	640	295	195	460	660	670	1145
14 DP100B - 8	1875	1650	445	415	680	335	160	600	760	695	1570
15 DP100BL - 10	2058	1850	540.5	502.5	680	335	160	600	820	840.5	1645
16 DP150 - 8	2734	2300	640	634	920	540	-	640	1010	940	1610
17 DP150L - 8	2734	2300	640	634	920	540	-	640	1010	940	1610
18 DP150B - 10	2794	2400	670	664	920	540	-	640	1010	970	1695

TECHNICAL DATA

• **Concept :**

The DP range of submersible pumps with agitator has been specially designed to handle heavy and abrasive slurries.

These centrifugal pumps with closed impeller, feature a unique agitator design. This agitator lifts sediments into suspension, creating a slurry mixture. This enables the continuous pumping of media with a high concentration of solids.

Robust construction, careful selection of materials and unique contour components, coupled with a low speed high torque motor, have produced a pump with excellent abrasion resistance as well as a sufficient weight and an important torque. These characteristics ensure long service life and economical operation.

The impeller, the wear plates and the agitator are manufactured in cast chrome iron (24 to 28 % Cr).

A strong short shaft, supported by a series of carefully selected bearings and a system of seals on double level of protection functioning in oil bath, ensure tightness in the hardest of conditions.

The DP15~150HP pumps are equipped with a series of lip seals in standard. They can be equipped with a double mechanical seal in option.

Servicing and maintaining the pumps to keep them in good working order is easy. On the DP pumps you have two wear plates, one of which is adjustable allowing simple adjustments to maintain long lasting high performance.

The electric class F motor is cooled by the liquid in which the pump is submerged.

The DP15~150HP pumps are available in different metallurgies, with thermal protection and moisture detector as well as in special versions for high temperatures or depths.

• **Operating conditions :**

DP15~150HP pumps can handle slurries with solid content of up to 60 % by weight, particle sizes up to 120 mm and liquid temperatures up to 60°C with pH levels between 4 and 9,5.

Special versions are available for liquid temperatures up to 80°C. Maximal standard operating depth is 30 m and 120m in special versions.

• **Electric power requirements* :**

Pumptype	Power kVA	Amp. 400 V
DP15/B	30	24
DP20/B	40	32
DP30/B	50	46
DP40B	65	58
DP50/B/BL/H	80	75
DPS50S	80	61
DP75B	120	116
DP100B/BL	150	150
DP150/L/B	220	215

*These figures are given as an indication.

• **Electric cable :**

The standard cable type to be used for connecting the pump is HO7RN-F and its specifications should correspond to the following :

Pumptype	Section	Outer diam. mm	Max. lenght cable/m/400V
DP15/B	4 x 10 mm ²	23	170
DP20/B	4 x 10 mm ²	23	120
DP30/B	4 x 16 mm ²	27	140
DP40B	4 x 35 mm ²	37	260
DP50/B/BL/H	4 x 35 mm ²	37	200
DPS50S	4 x 35 mm ²	37	250
DP75B	4 x 35 mm ²	37	130
DP100B/BL	4 x 50 mm ²	43	130
DP150/L/B	4 x 95 mm ²	58	170

• **Starter :**

A reactor starter must be used to start DP15~150HP pumps.

